

OKO OKNA



Katalog techniczny



Catalogue Technique



Technische Catalogus



Technischer Katalog



Catalogo Tecnico

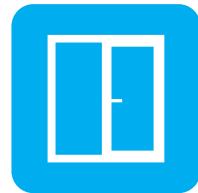

Streamline 76



BluEvolution 82



BluEvolution 92

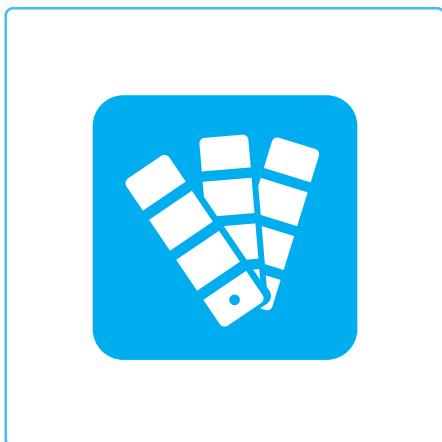
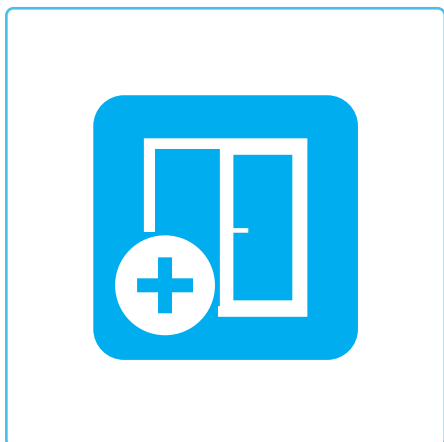



Streamline 76 Classic-line



Streamline 76 Round-line



Streamline 76 | 5 komór | 2 uszczelki
Stal pokazana na rysunku może nie być stalą stosowaną standardowo.



Streamline 76 | 5 chambres | 2 joints
Renfort en acier présenté sur le dessin ci-dessus est en option.



Streamline 76 | 5 kamers | 2 afdichtingen
Staal die u op de tekening ziet, is niet standaard.



Streamline 76 | 5 Kammern | 2 Dichtungen
Der angewendete Stahlkern kann von dem abgebildeten Kern abweichen.



Streamline 76 | 5 camere | 2 guarnizioni
L'acciaio presentato sul disegno può essere un acciaio non standard.



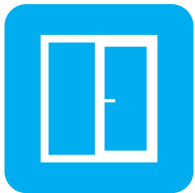

Streamline 76



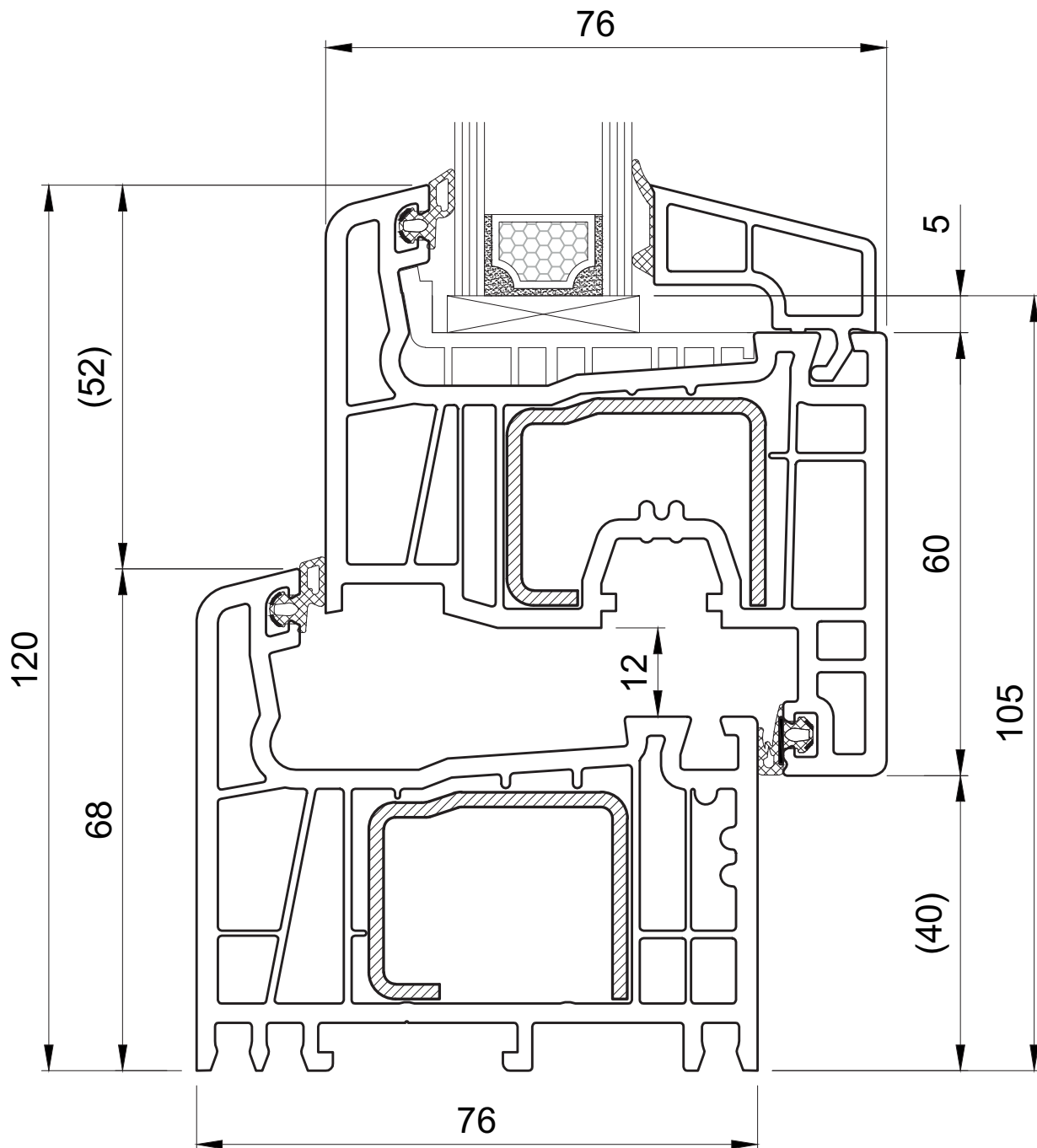

250 221 - 251 021

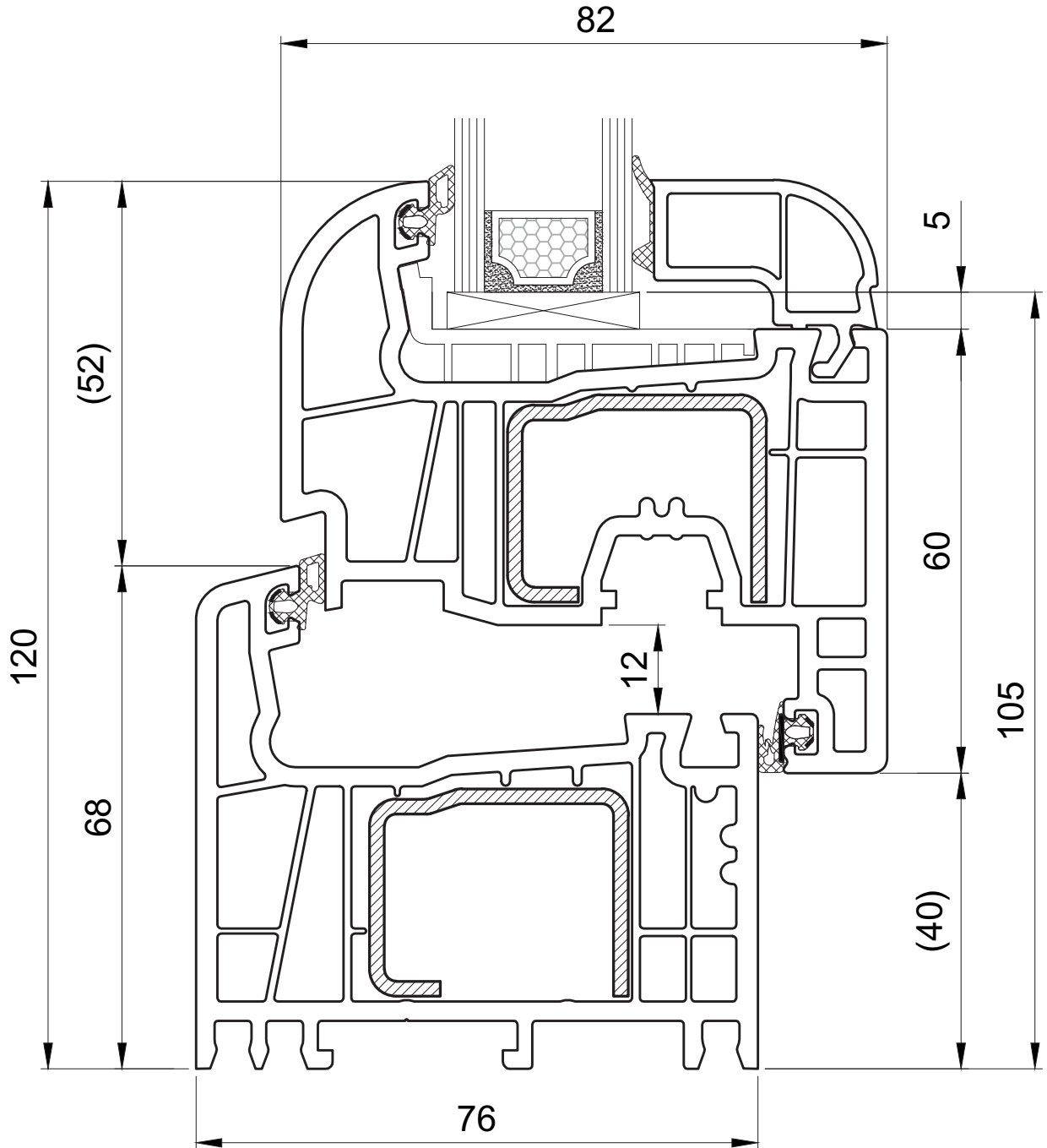

SALAMANDER
WINDOW & DOOR SYSTEMS

- Rama i skrzydło Classic-line
- Dormant + ouvrant Classic-line
- Kader + vleugel Classic-line
- Rahmen + Flügel Classic-line
- Telaio + ante Classic-line



-  Rama i skrzydło Round-line
-  Dormant + ouvrant Round-line
-  Kader + vleugel Round-line
-  Rahmen + Flügel Round-line
-  Telaio + ante Round-line



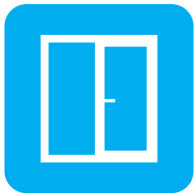



Streamline 76

250 221

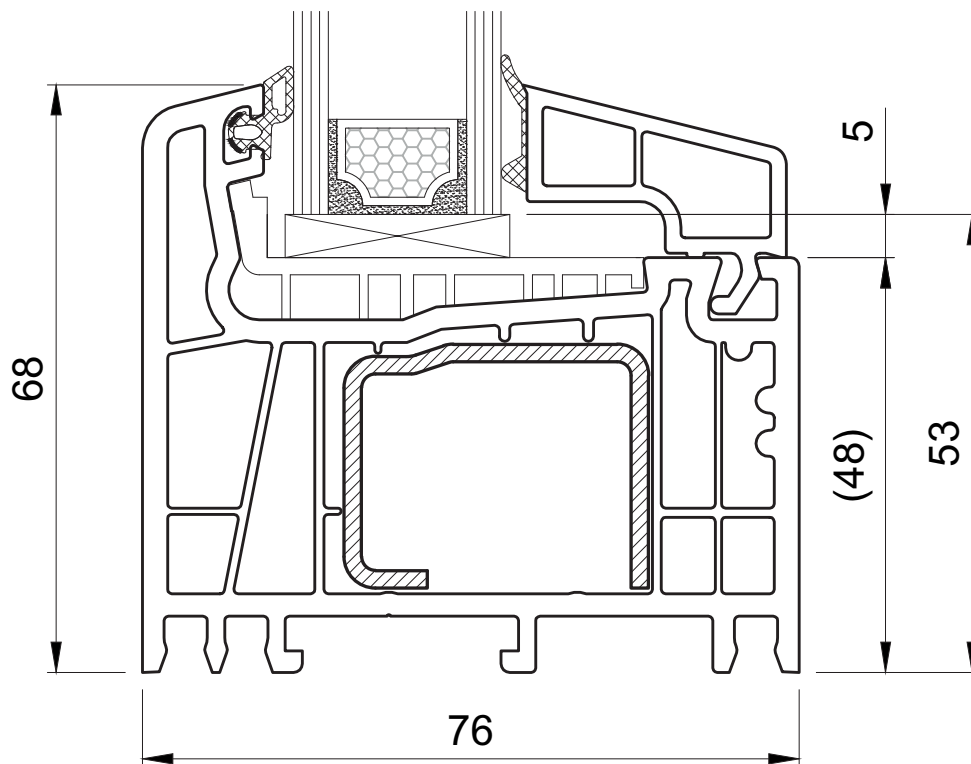
**OKO
OKNA**



SALAMANDER
WINDOW & DOOR SYSTEMS

Standardowe szklenie w ramie 





Dormant de fenêtre standard 

Raamkader standard 

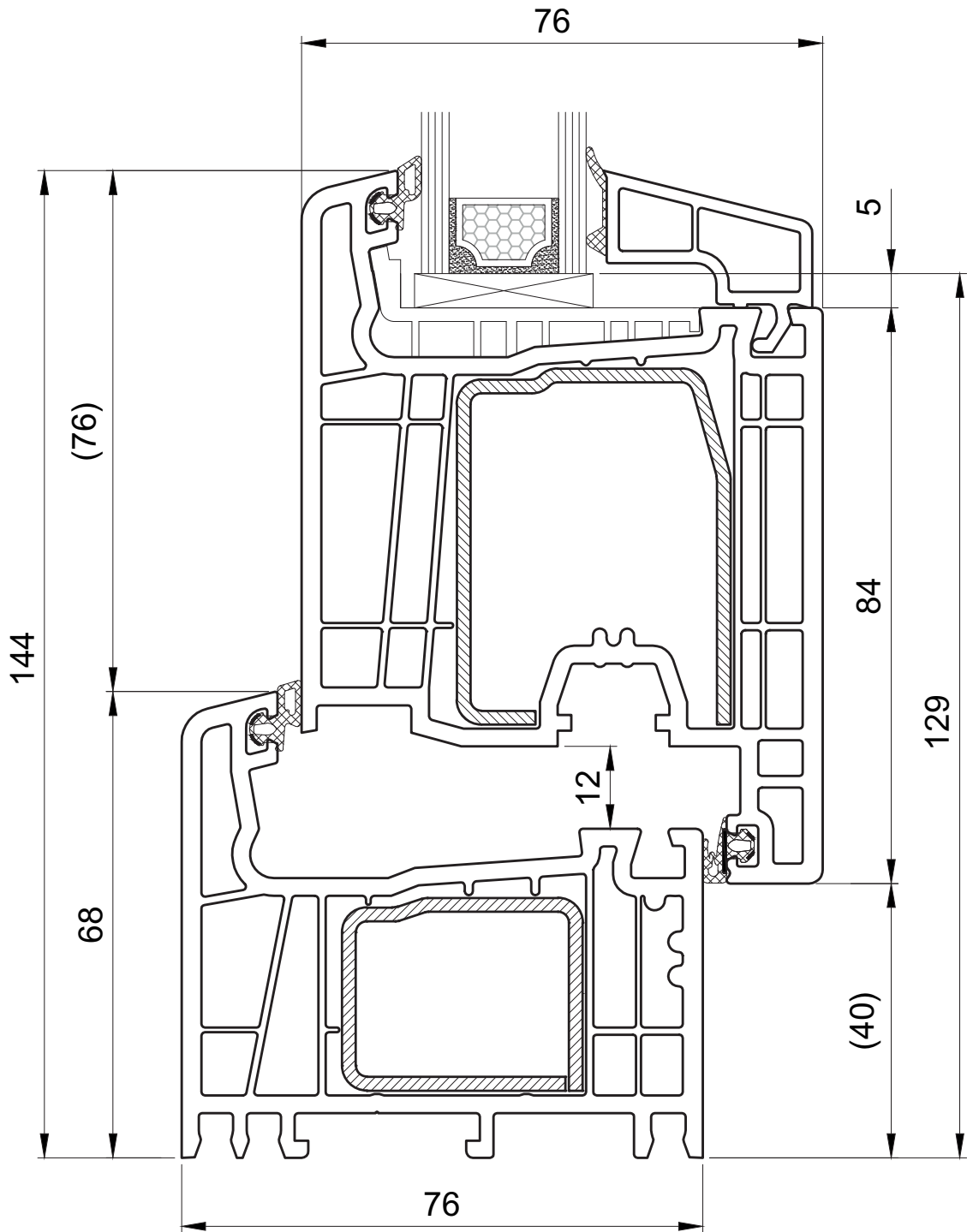
Fensterrahmen standard 

Telaio finestra standard 



-  Drzwi typu B lub skrzydło tarasowe, otwierane do wewnątrz
-  Porte type B ou profil de porte de passage, ouverture vers l'intérieur
-  Deur versie B, terras profiel, naar binnen opendraaiend
-  Nebeneingangstür oder Terrassentür, nach Innen öffnend
-  Porta la versione „B” o profilo portaveranda, l'apertura verso interno





Streamline 76

250 221 - 351 030

**OKO
OKNA**

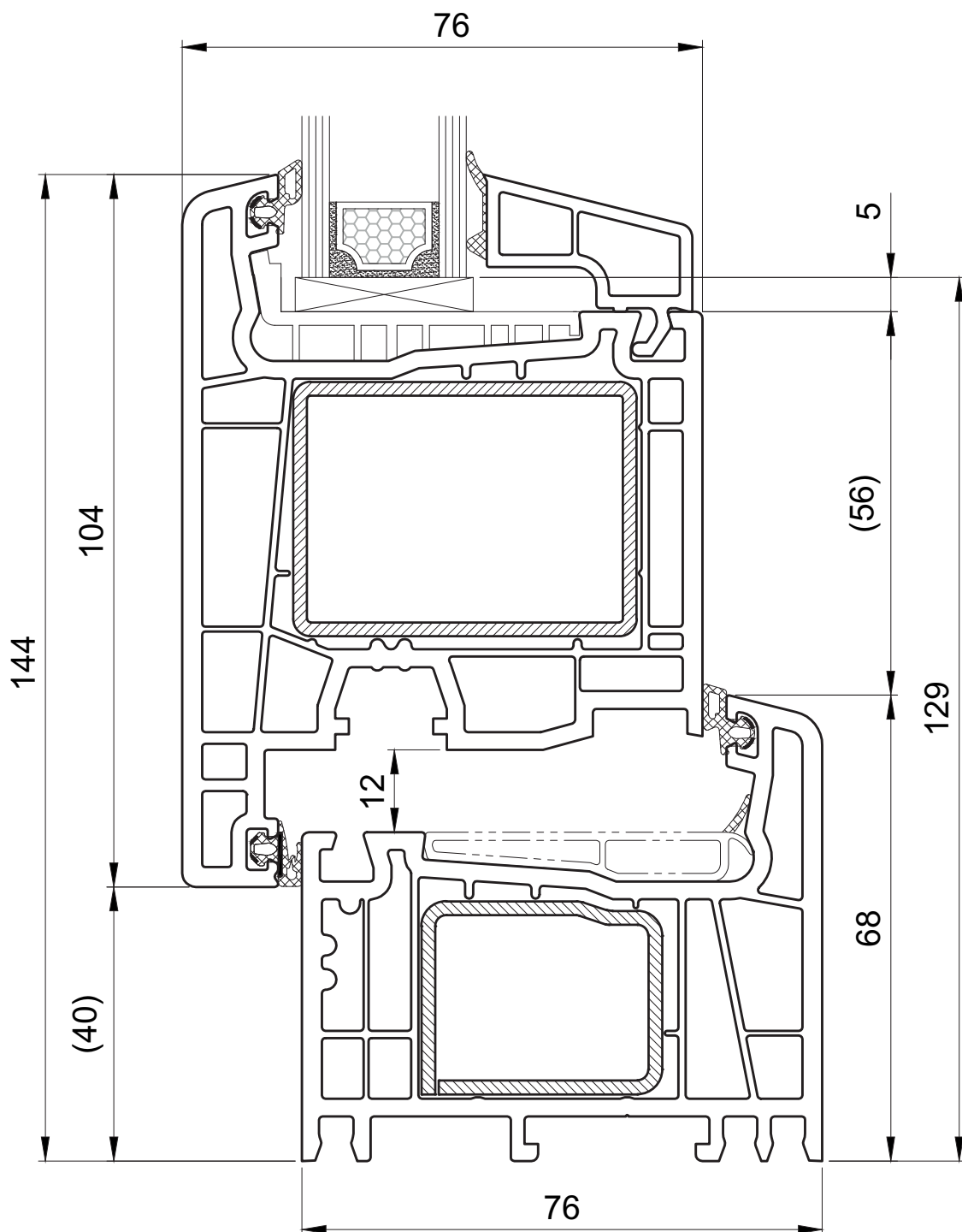

Drzwi typu B lub skrzydło tarasowe otwierane na zewnątrz

Porte type B ou profil de passage, ouverture vers l'extérieur

Deur versie B, terras profiel, naar buiten opendraaiend





Nebeneingangstür oder Terrasantür, nach Aussen öffnend

Porta la versione „B” o profilo portaveranda, l'apertura verso esterno

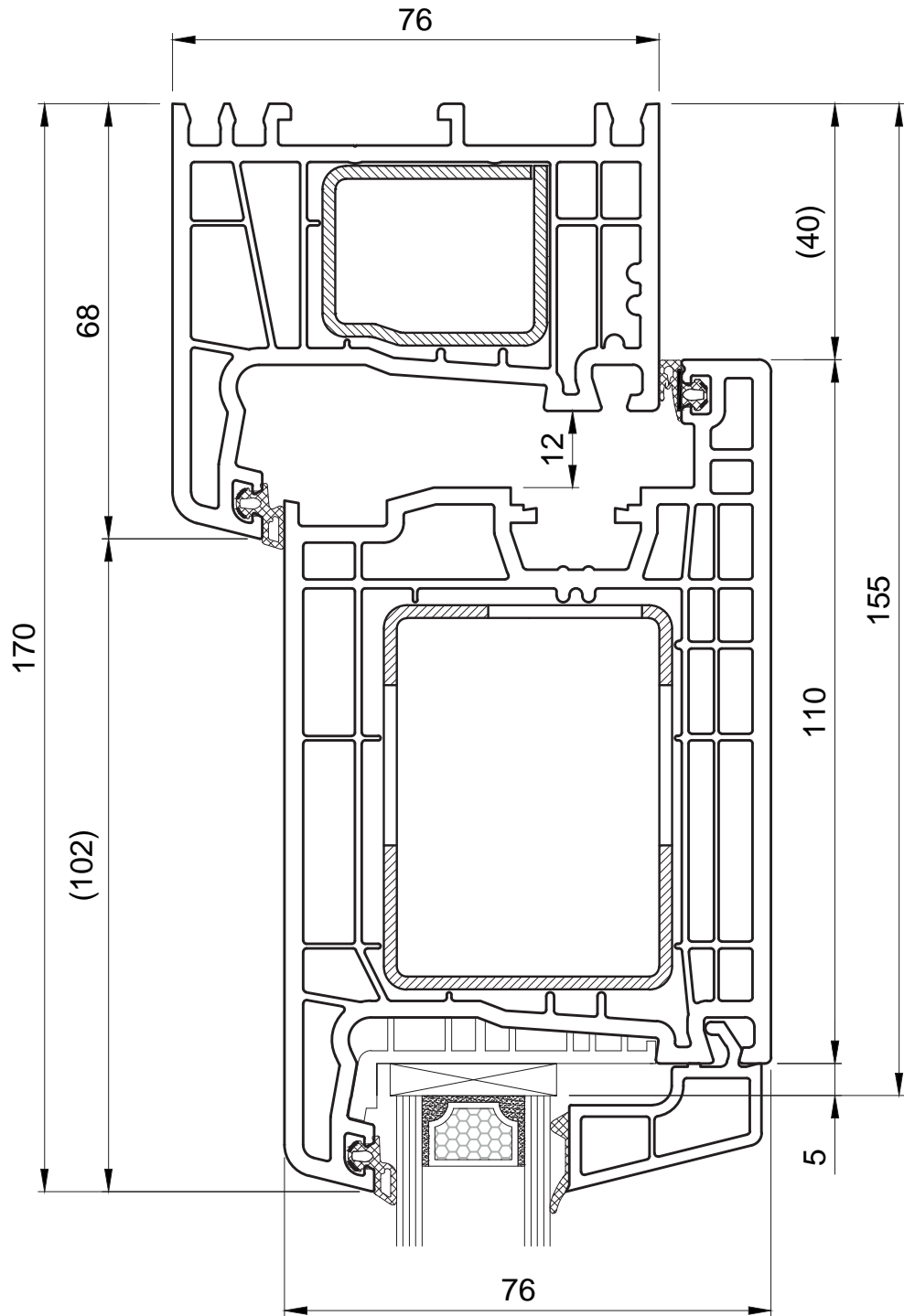

SALAMANDER
WINDOW & DOOR SYSTEMS



-  Drzwi wejściowe typu A, otwierane do wewnątrz
-  Porte d'entrée type A, ouverture vers l'intérieur
-  Deur versie A, naar binnen opendraaiend
-  Eingangstür Version „A“ nach Innen öffnend
-  Porta la versione „A“, l'apertura verso interno





Streamline 76

250 221 - 351 040

**OKO
OKNA**

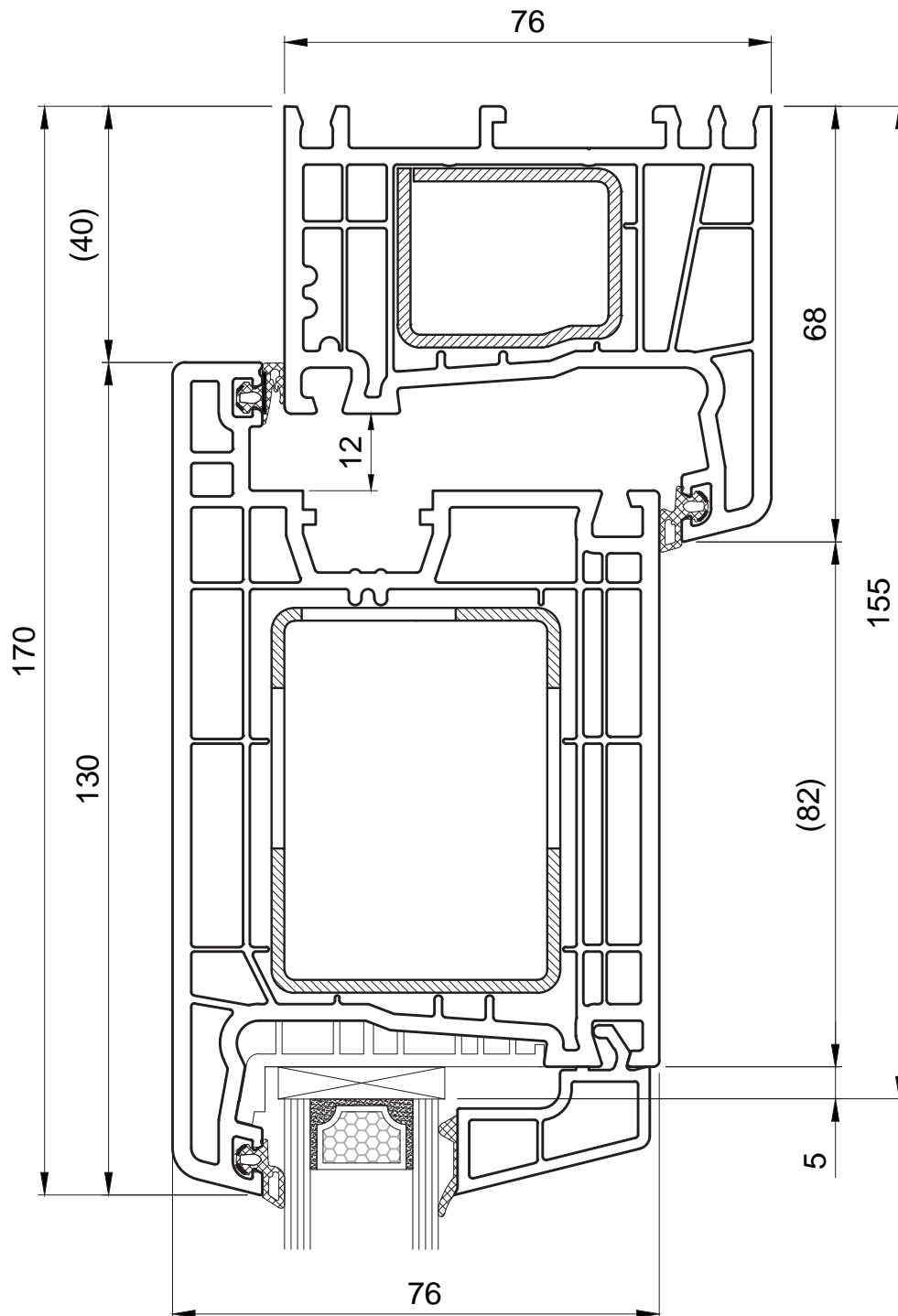

Drzwi wejściowe wersja A, otwierane na zewnątrz



Porte d'entrée type A, ouverture vers l'extérieur



Deur versie A, naar buiten opendraaiend









Eingangstür Version „A“ nach Aussen öffnend

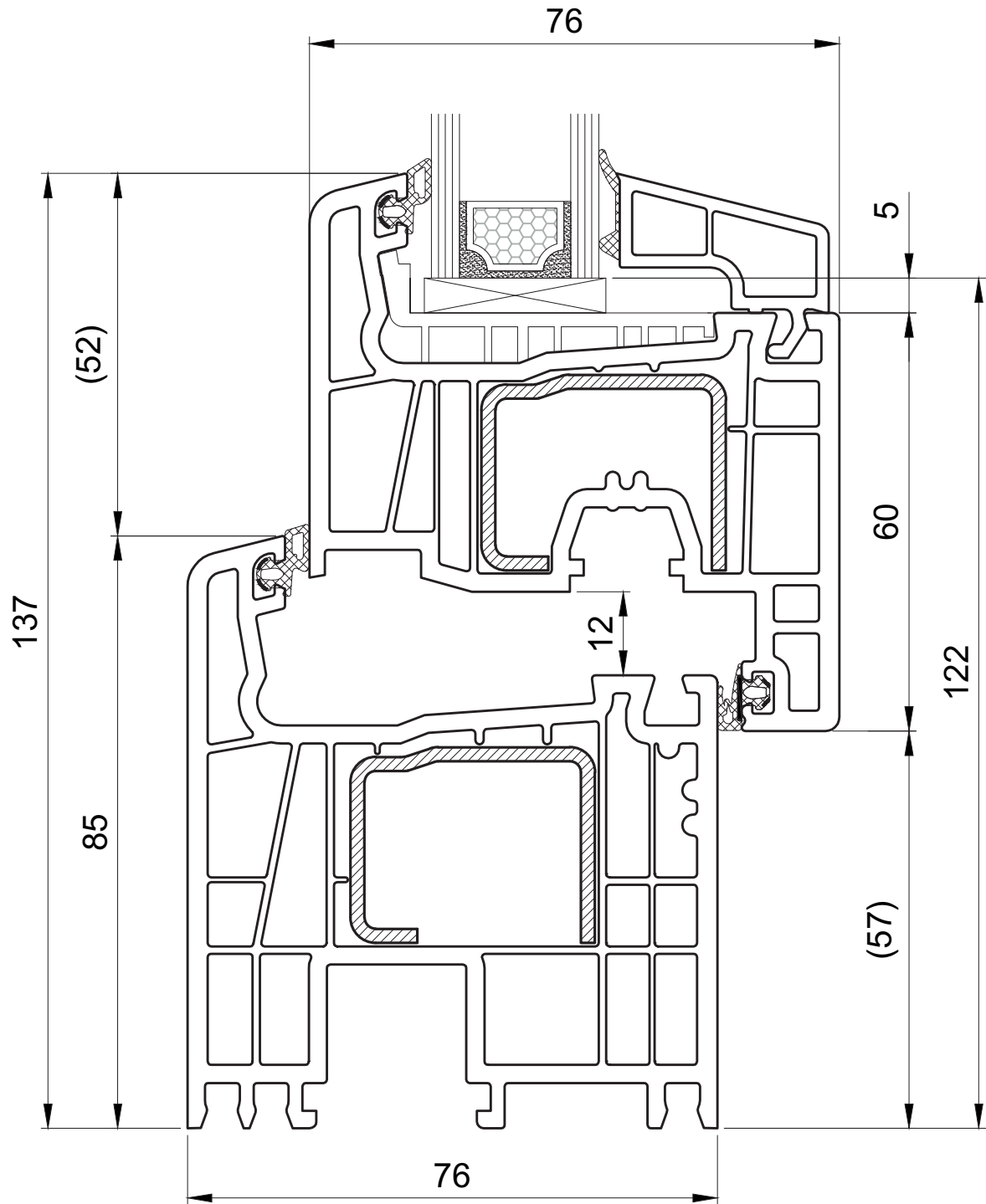
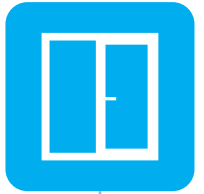

Porta la versione „A“, l'apertura verso esterno





-  Skrzydło okienne Classic-line + rama drzwiowa
-  Overant de fenêtre Classic-line avec dormant de porte
-  Raamvleugel Classic-line + deurkader
-  Fensterflügel Classic-line + Türrahmen
-  Anta finestra Classic-line + telaio della porta



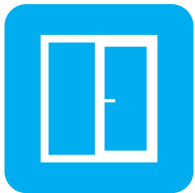

Streamline 76

250 234 - 251 221

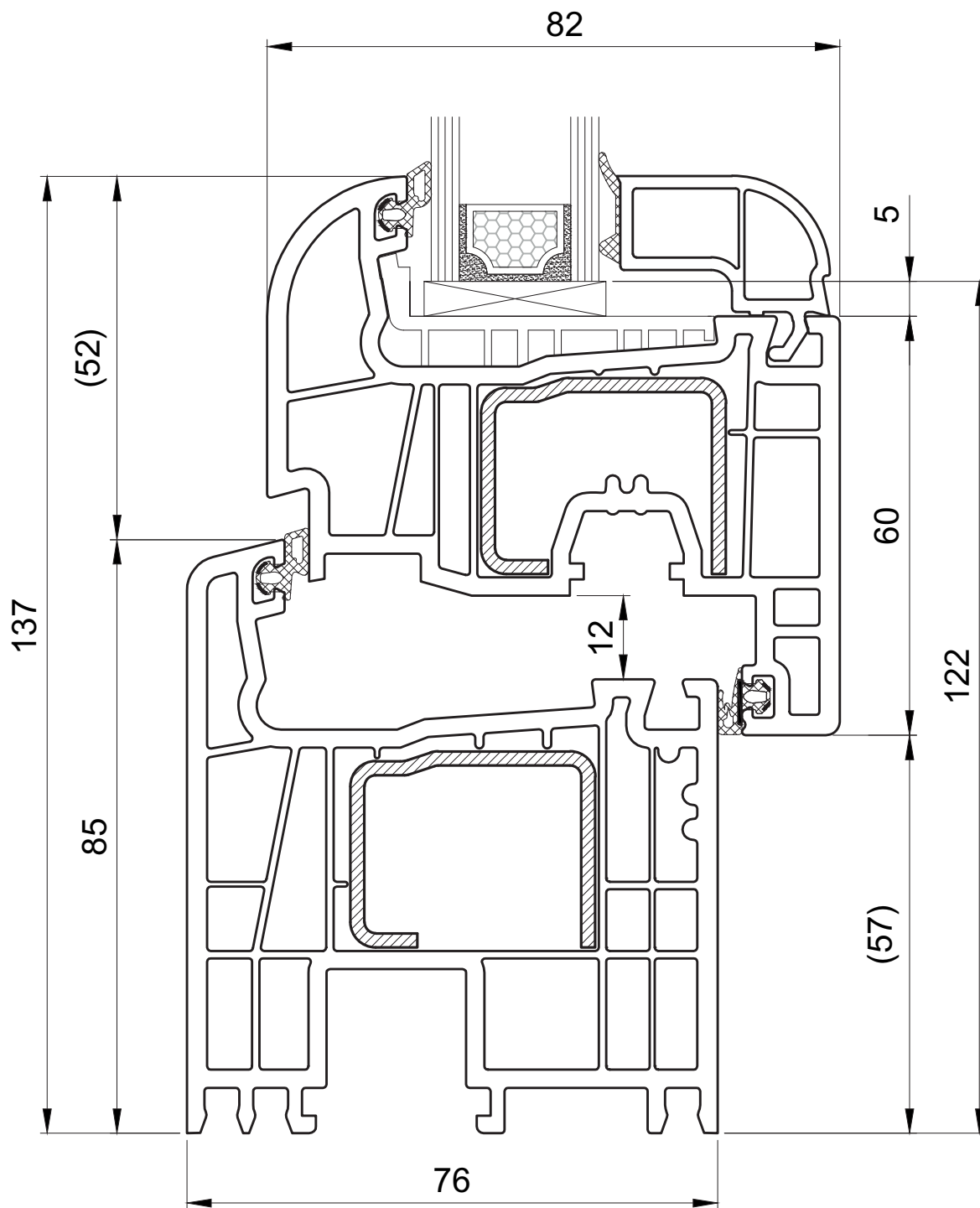

SALAMANDER
WINDOW & DOOR SYSTEMS

Skrzydło okienne Round-line + rama drzewiowa



Profil de fenêtre Round-line + dormant plus haut



Raamprofiel Round-line met verhoogde kader



Fensterprofil Round-line mit höherem Rahmen



Profilo della finestra Round-line con telaio maggiore



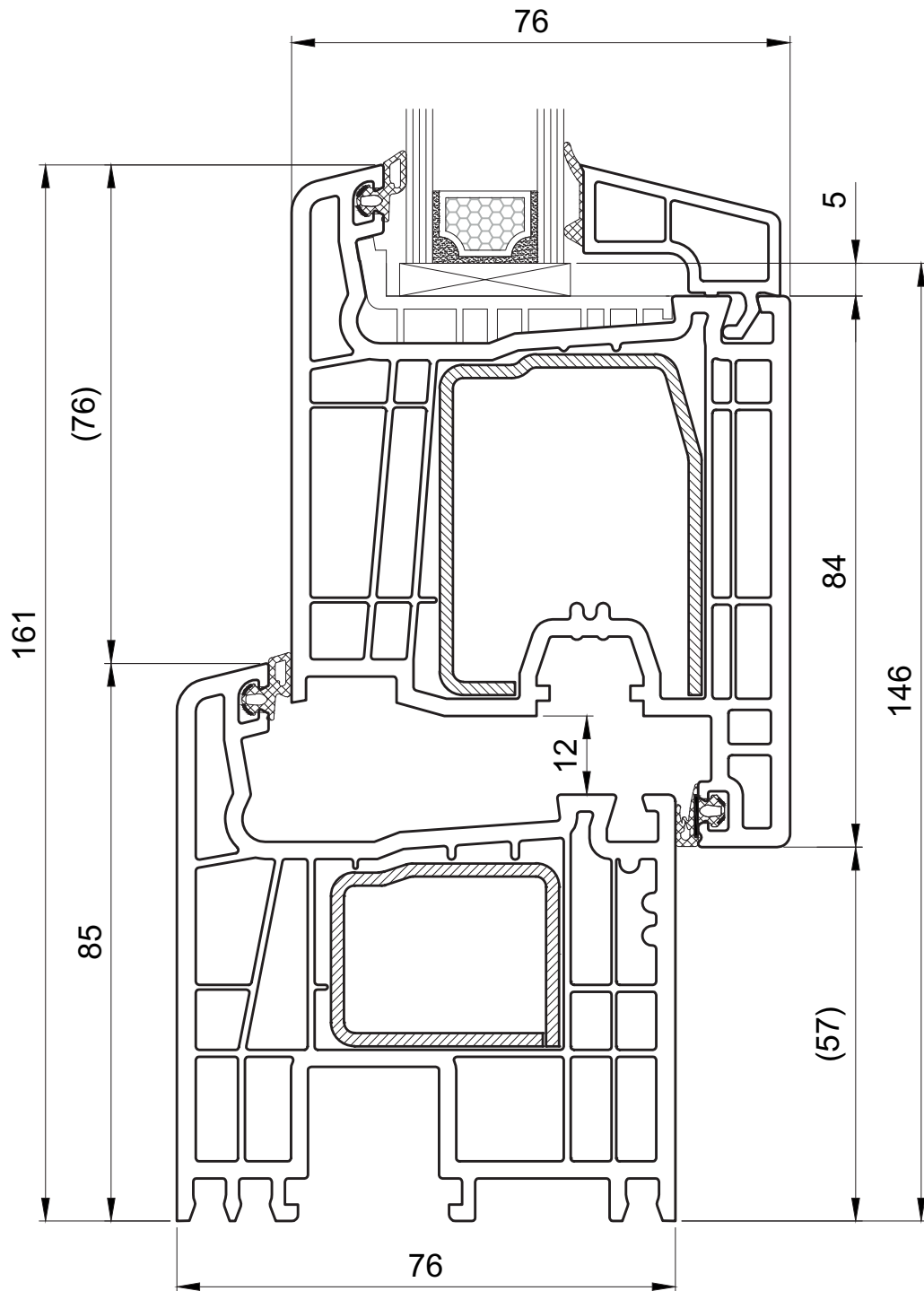

Drzwi typu B lub drzwi tarasowe, otwierane do wewnątrz



Porte type B ou profil de porte de passage avec seuil, ouverture vers l'intérieur



Deur versie B, terras profiel met drempel, naar binnen opendraaiend



Nebeneingangstür oder Terrasantür mit Schwelle, nach Innen öffnend



Porta la versione „B” o profilo portaveranda con soglia, l'apertura verso interno





Streamline 76

250 234 - 351 030

**OKO
OKNA**

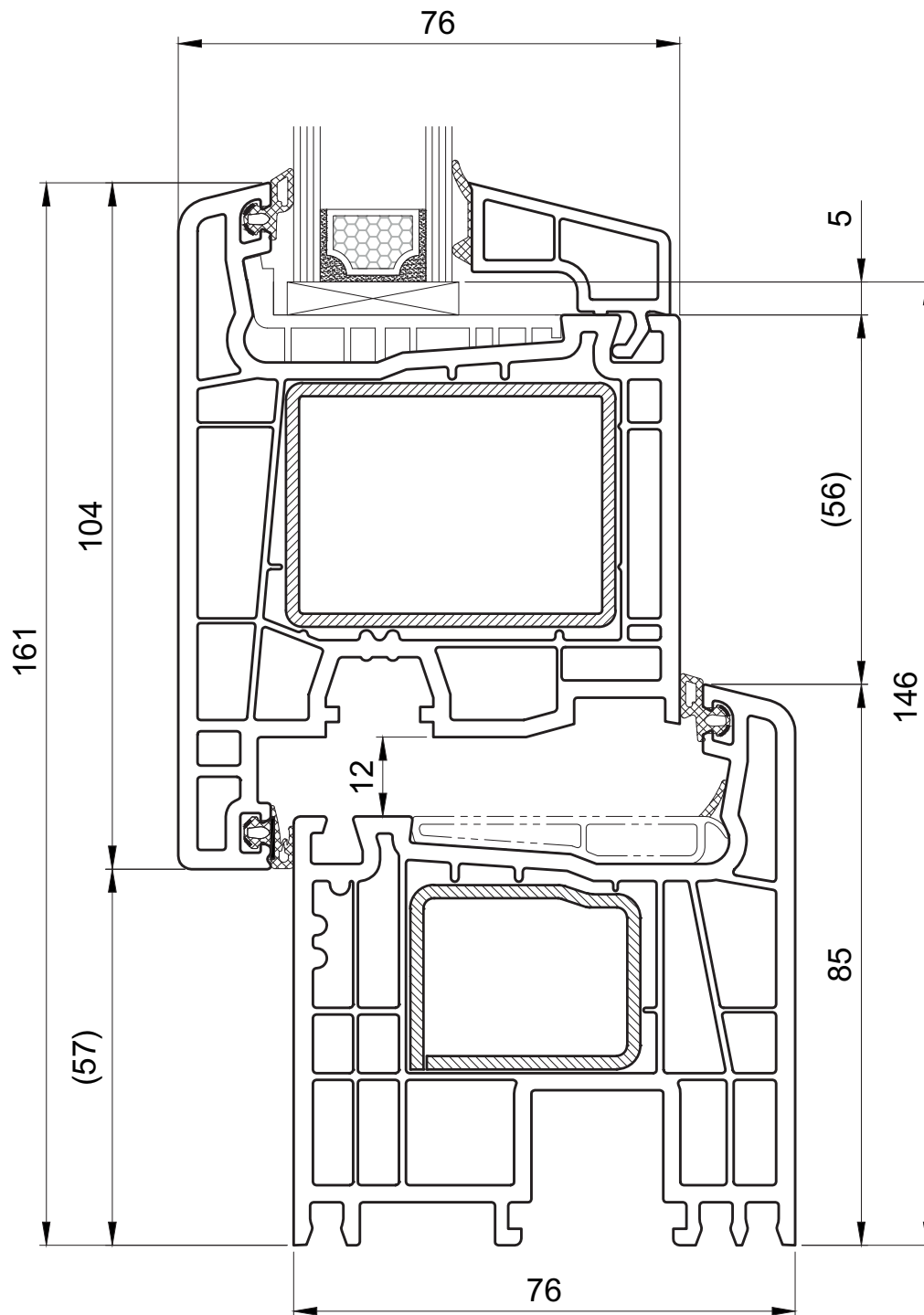

Drzwi wejściowe typu B lub drzwi tarasowe, otwierane na zewnątrz

Porte type B ou profil de passage, ouverture vers l'extérieur

Deur versie B, terras profiel, naar buiten opendraaiend





Nebeneingangstür oder Terrassentür, nach Aussen öffnend

Porta la versione „B” o profilo portaveranda, l'apertura verso esterno

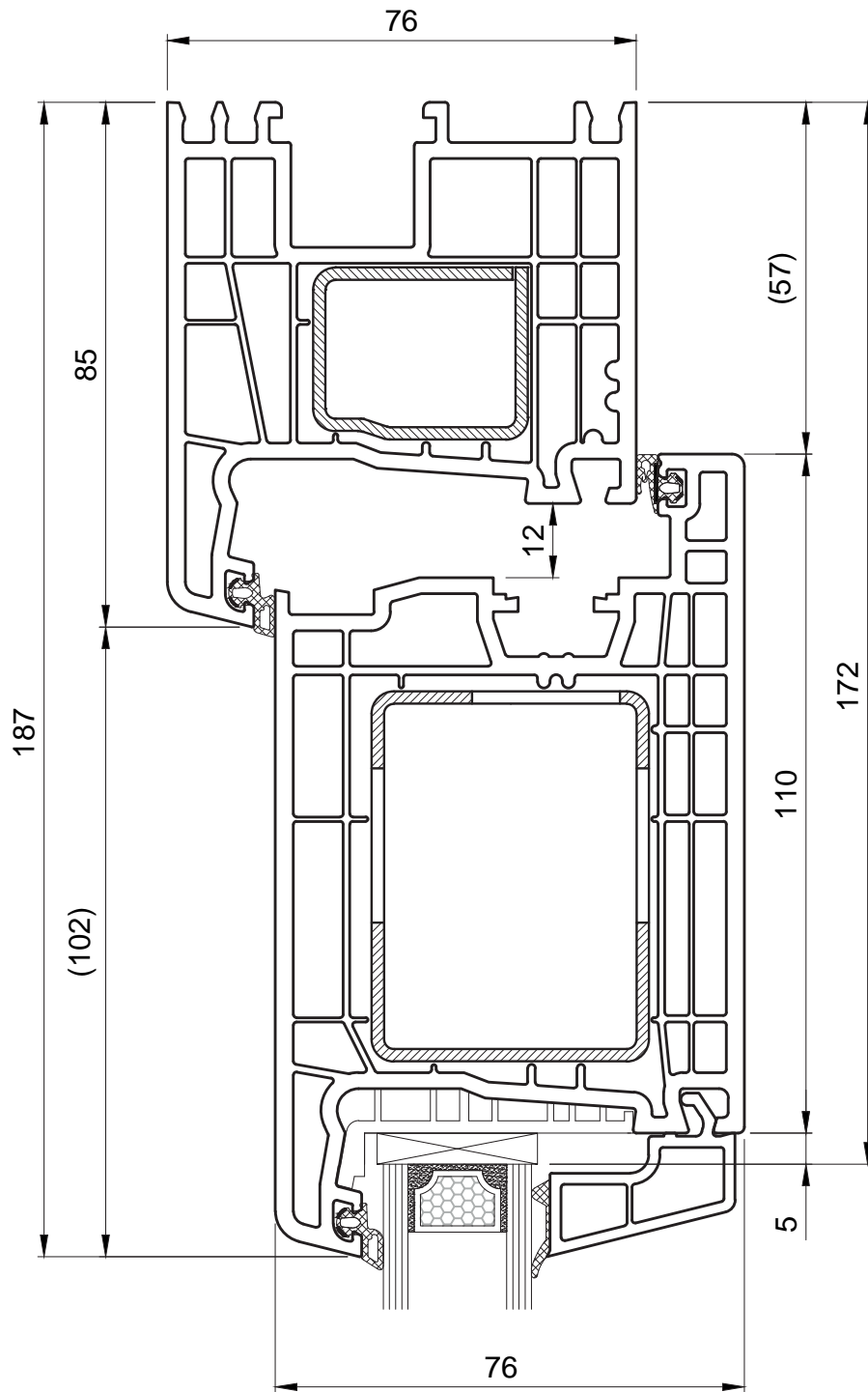

SALAMANDER
WINDOW & DOOR SYSTEMS



-  Drzwi wejściowe typu A, otwierane do wewnątrz
-  Porte d'entrée type A, ouverture vers l'intérieur
-  Deur versie A, naar binnen opendraaiend
-  Eingangstür Version „A“ nach Innen öffnend
-  Porta la versione „A“, l'apertura verso interno





Streamline 76

250 234 - 351 040

**OKO
OKNA**

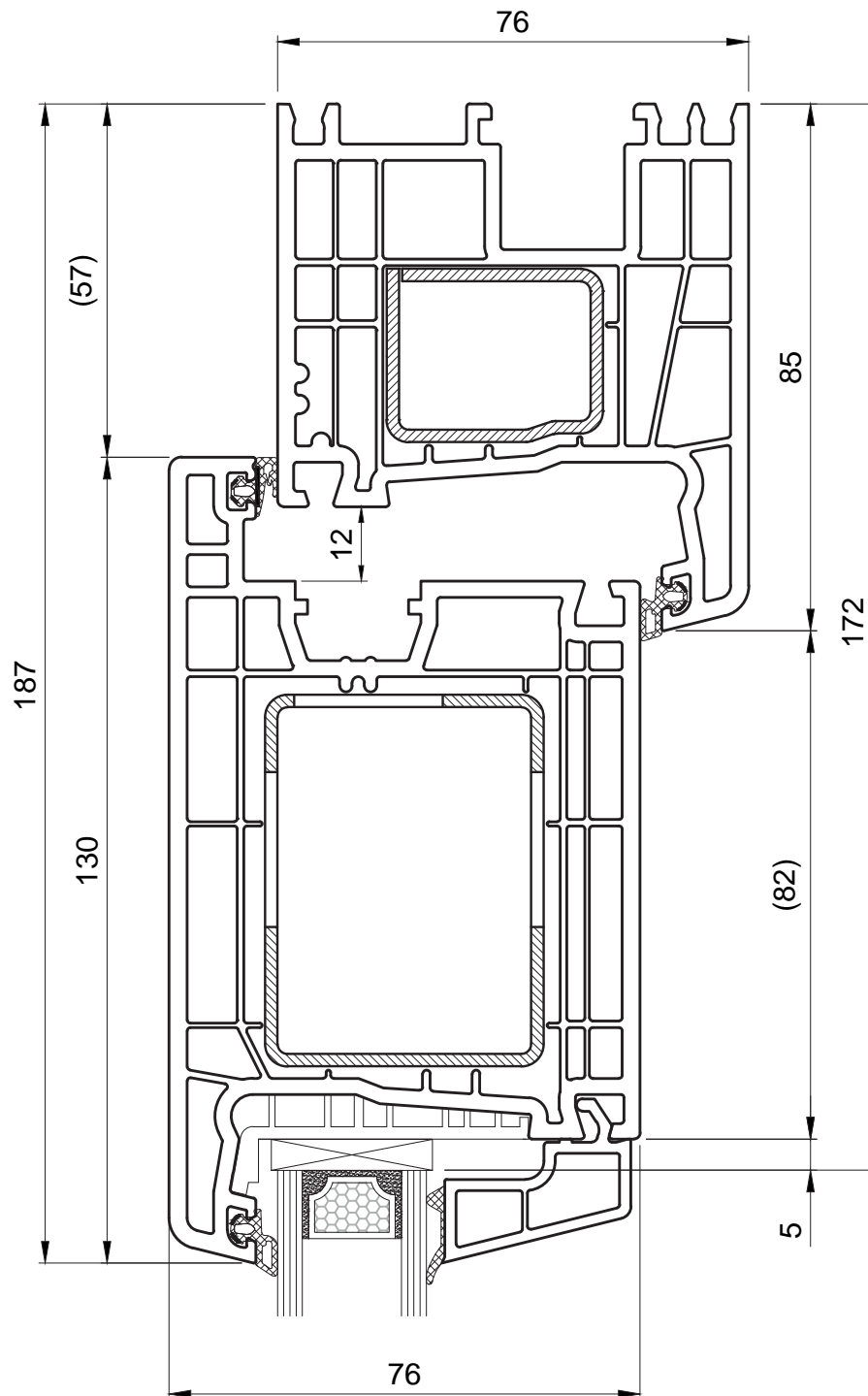

Drzwi wejściowe typu A, otwierane na zewnątrz



Porte d'entrée type A, ouverture vers l'extérieur



Deur versie A, naar buiten opendraaiend



Eingangstür Version „A“ nach Aussen öffnend



Porta la versione „A“, l'apertura verso esterno



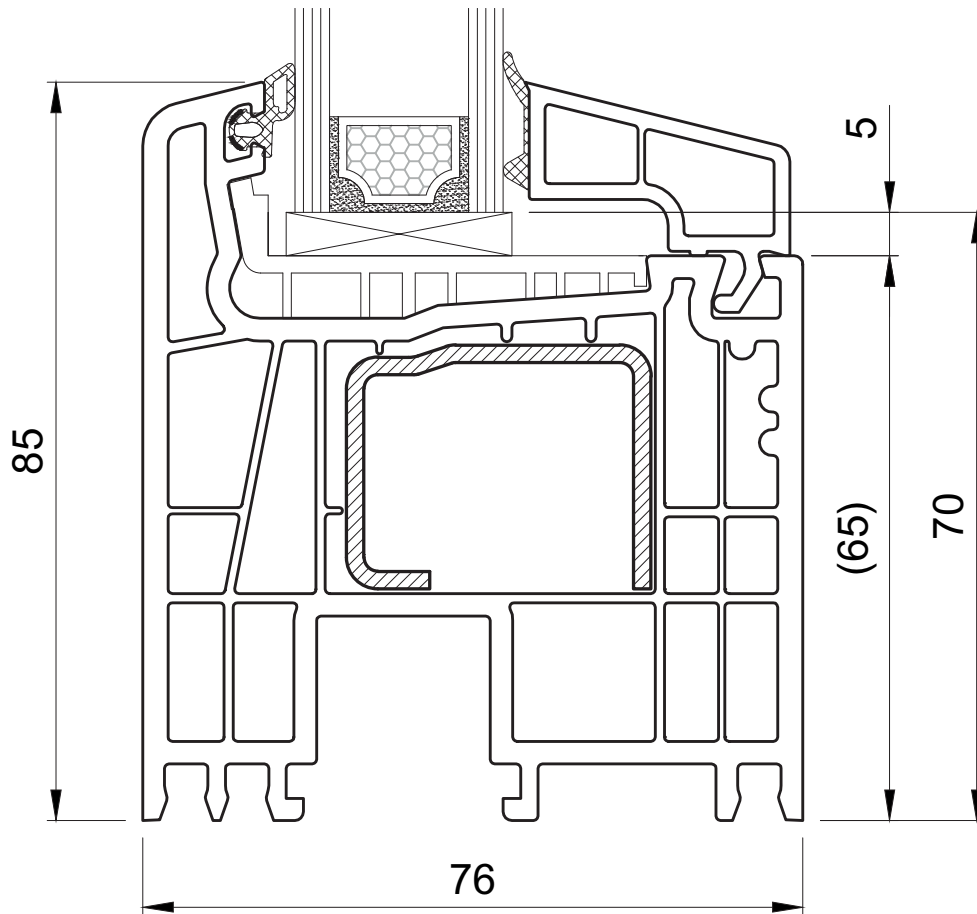

-  Szklenie w ramie
-  Fixe - dormant
-  Vast raam - kader
-  Festverglasung - Rahmen
-  Serramento fisso - telaio



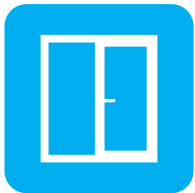

Streamline 76

250 100 - 251 021

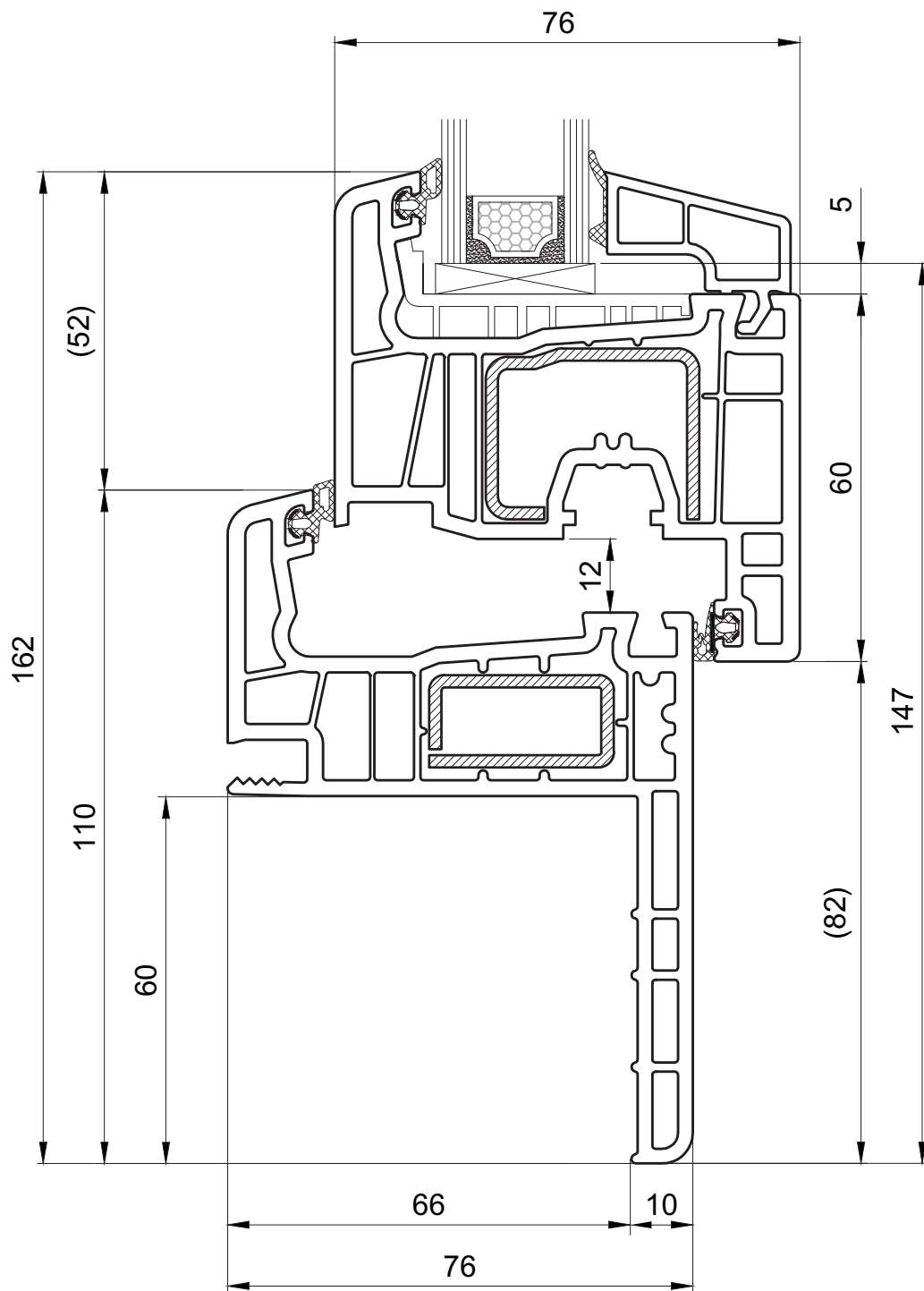

SALAMANDER
WINDOW & DOOR SYSTEMS

RENOWACJA - Płetwa 60 mm ze skrzydłem Classic-line



RENOVATION - Aile de 60 mm avec ouvrant Classic-line



RENOVATIE - Lip 60 mm + vleugel Classic-line









RENOVIERUNG - Flosse 60 mm mit Flügel Classic-line

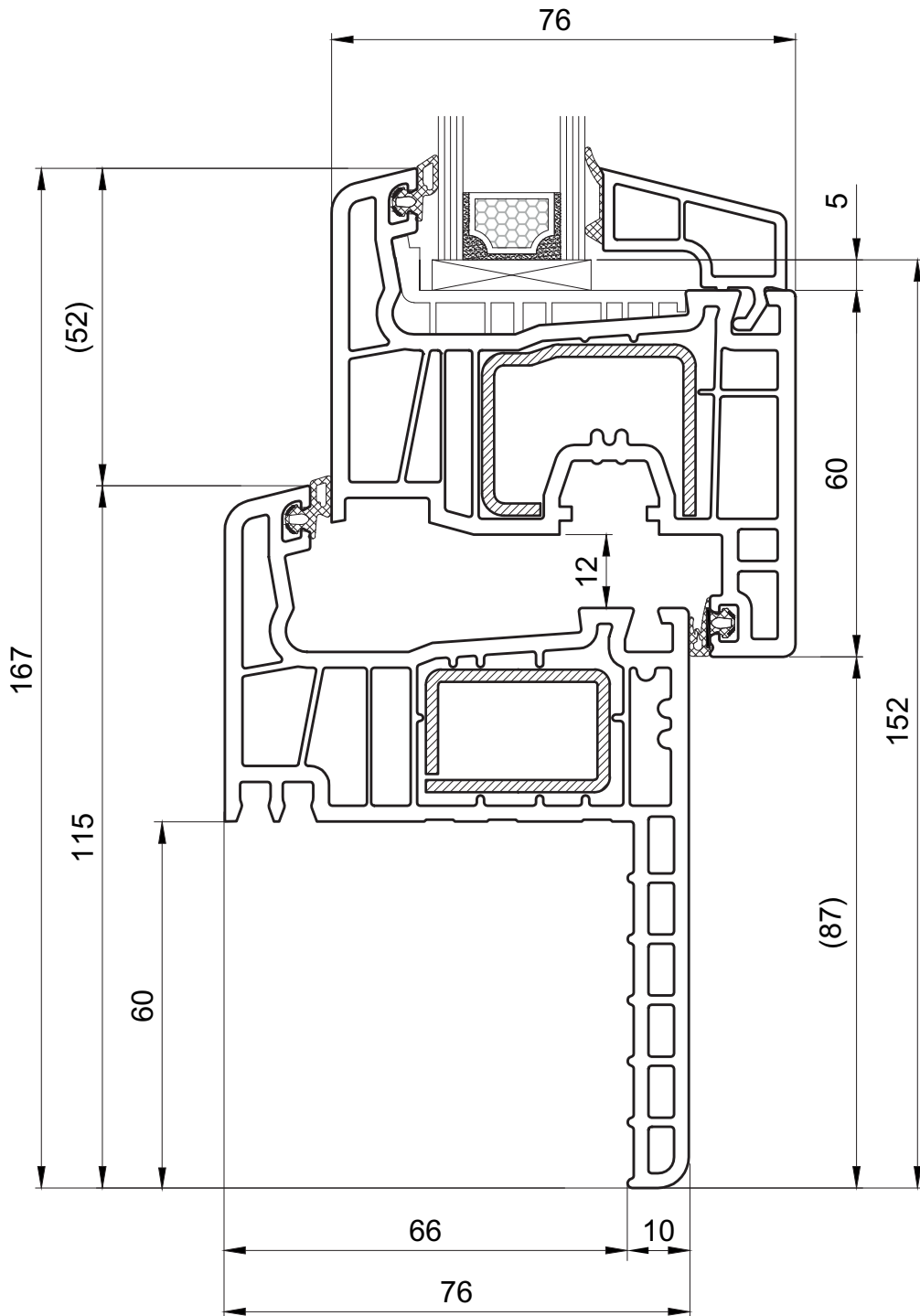
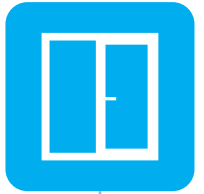

RINNOVAZIONE - Aletta da 60 mm con anta Classic-line





-  RENOWACJA - Płetwa 60 mm ze skrzydłem Classic-line
-  RENOVATION - Aile de 60 mm avec ouvrant Classic-line
-  RENOVATIE - Lip 60 mm + vleugel Classic-line
-  RENOVIERUNG - Flosse 60 mm mit Flügel Classic-line
-  RINNOVAZIONE - Aletta da 60 mm con anta Classic-line



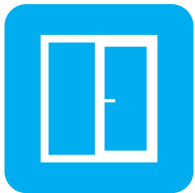

Streamline 76

250 100 - 251 221

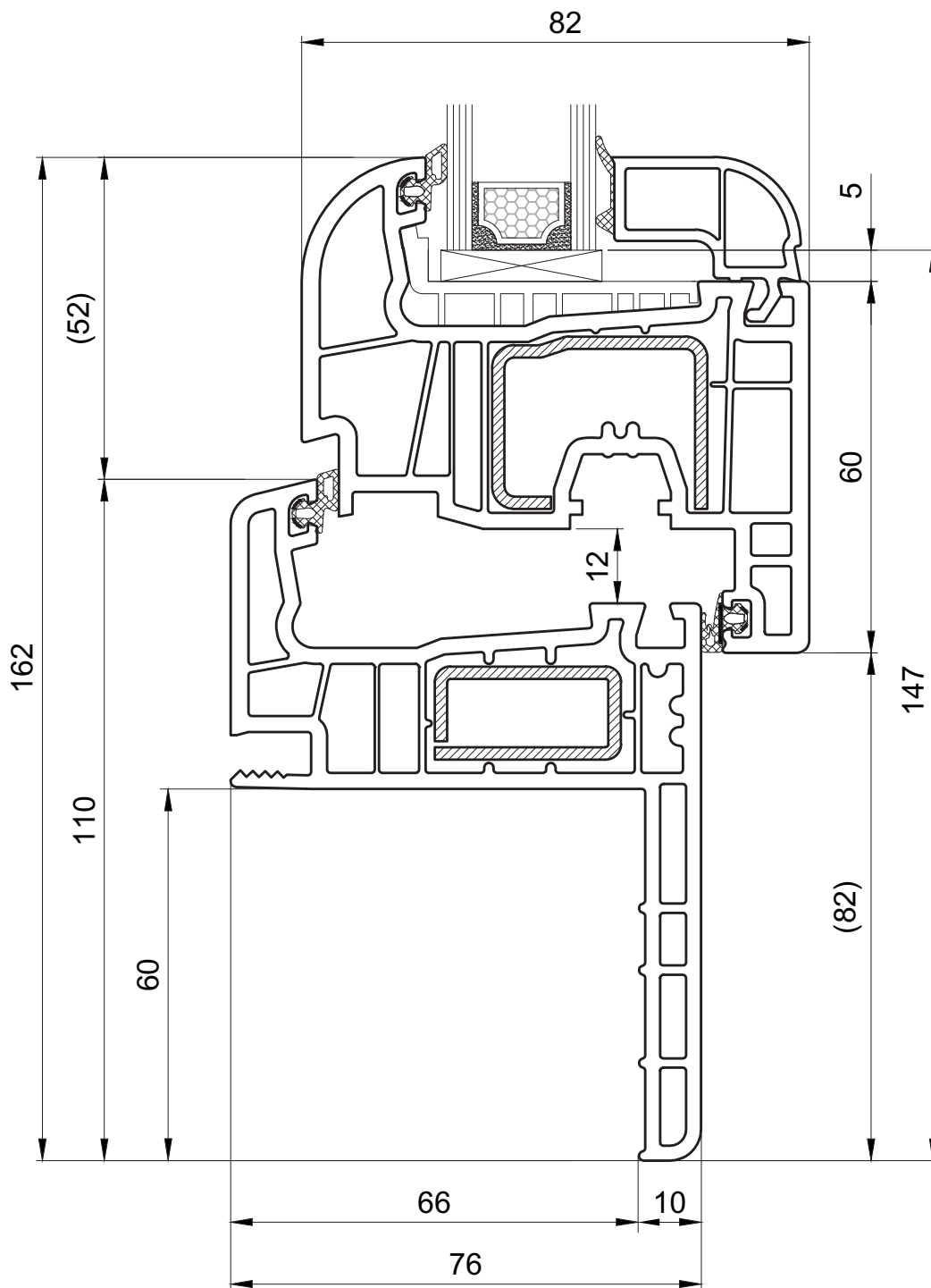

RENOWACJA - Płetwa 60 mm ze skrzydłem Round-line



RENOVATION - Aile de 60 mm avec ouvrant Round-line



RENOVATIE - Lip 60 mm + vleugel Round-line









RENOVIERUNG - Flosse 60 mm mit Flügel Round-line

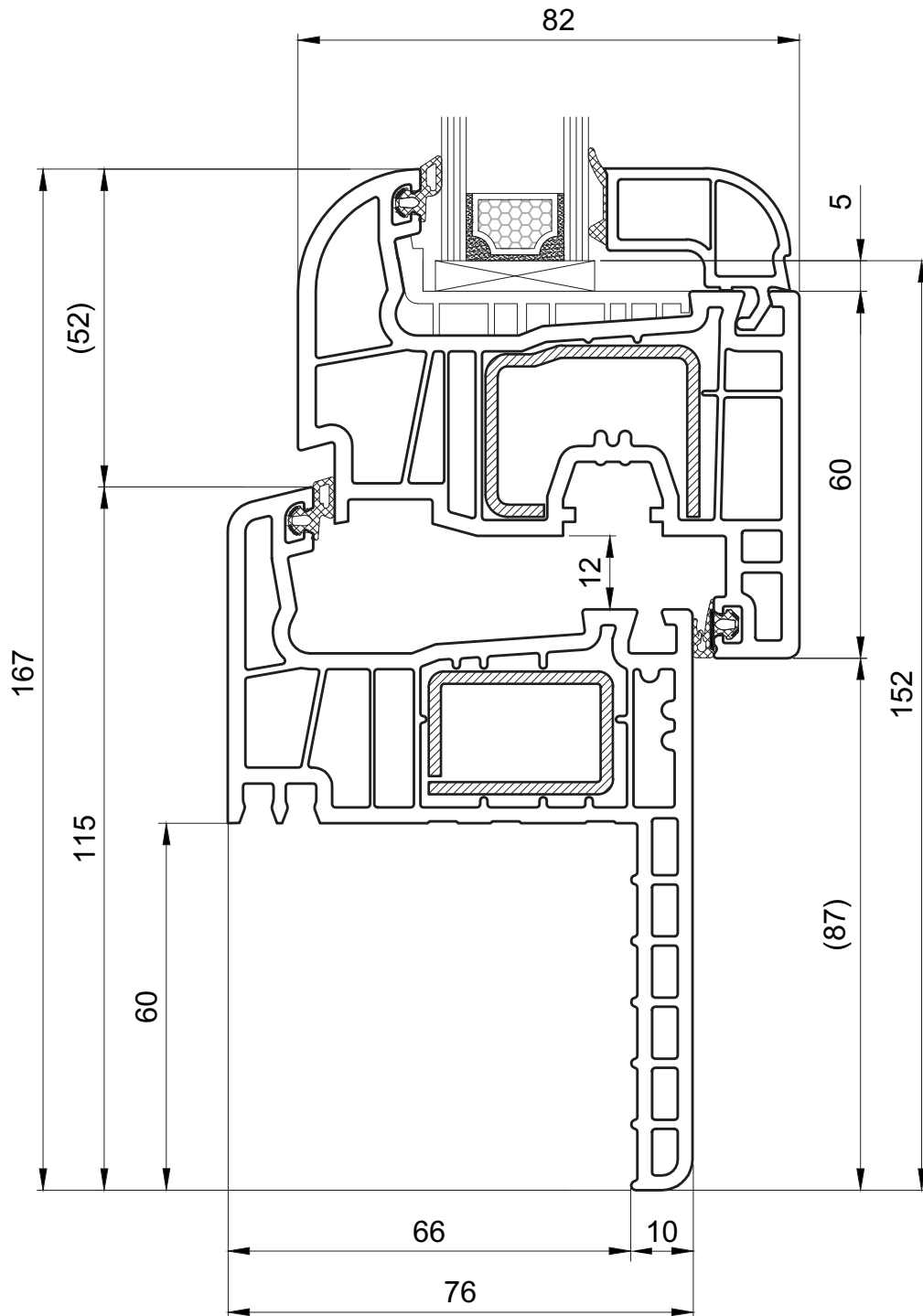
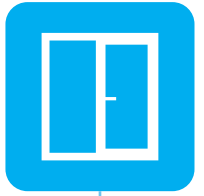

RINNOVAZIONE - Aletta da 60 mm con anta Round-line





-  RENOWACJA - Płetwa 60 mm ze skrzydłem Round-line
-  RENOVATION - Aile de 60 mm avec ouvrant Round-line
-  RENOVATIE - Lip 60 mm + vleugel Round-line
-  RENOVIERUNG - Flosse 60 mm mit Flügel Round-line
-  RINNOVAZIONE - Aletta da 60 mm con anta Round-line



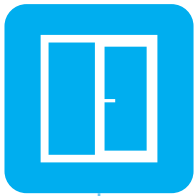

Streamline 76

250 154 - 251 021

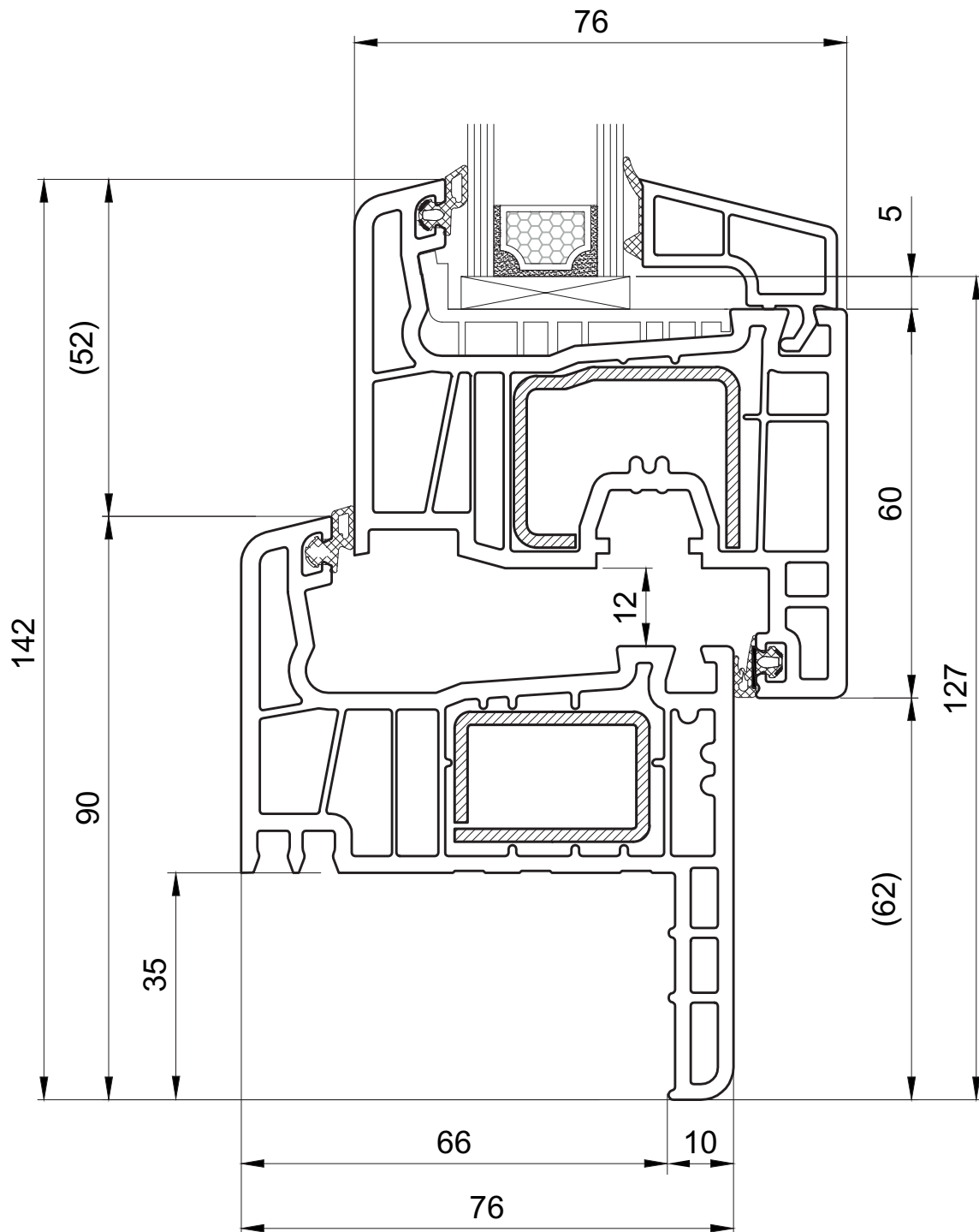

RENOWACJA - Płetwa 35 mm ze skrzydłem Classic-line



RENOVATION - Aile de 35 mm avec ouvrant Classic-line



RENOVATIE - Lip 35 mm + vleugel Classic-line









RENOVIERUNG - Flosse 35 mm mit Flügel Classic-line

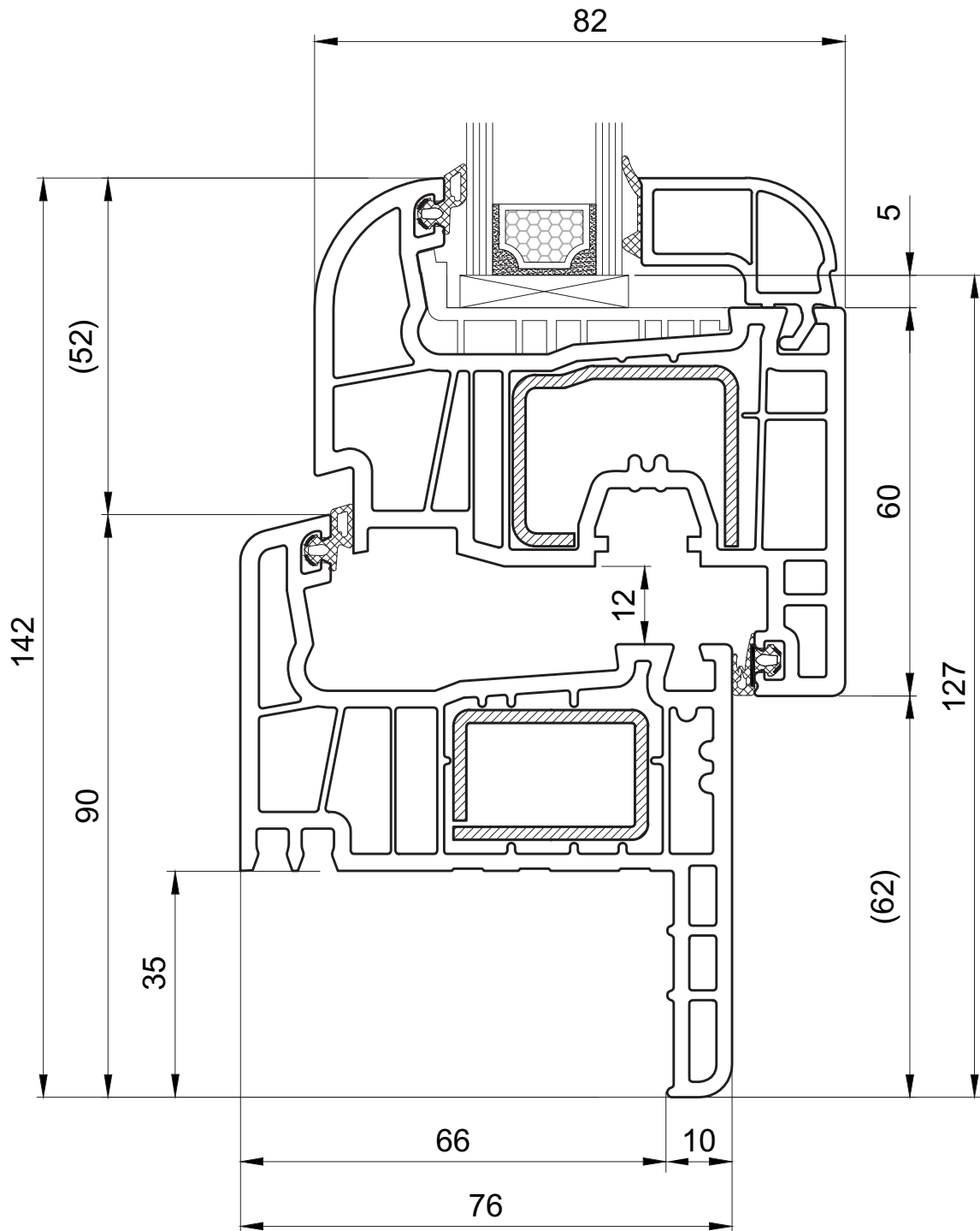

RINNOVAZIONE - Aletta da 35 mm con anta Classic-line





-  RENOWACJA - Płetwa 35 mm ze skrzydłem Round-line
-  RENOVATION - Aile de 35 mm avec ouvrant Round-line
-  RENOVATIE - Lip 35 mm + vleugel Round-line
-  RENOVIERUNG - Flosse 35 mm mit Flügel Round-line
-  RINNOVAZIONE - Aletta da 35 mm con anta Round-line





Streamline 76

251 021 - 548 523

**OKO
OKNA**

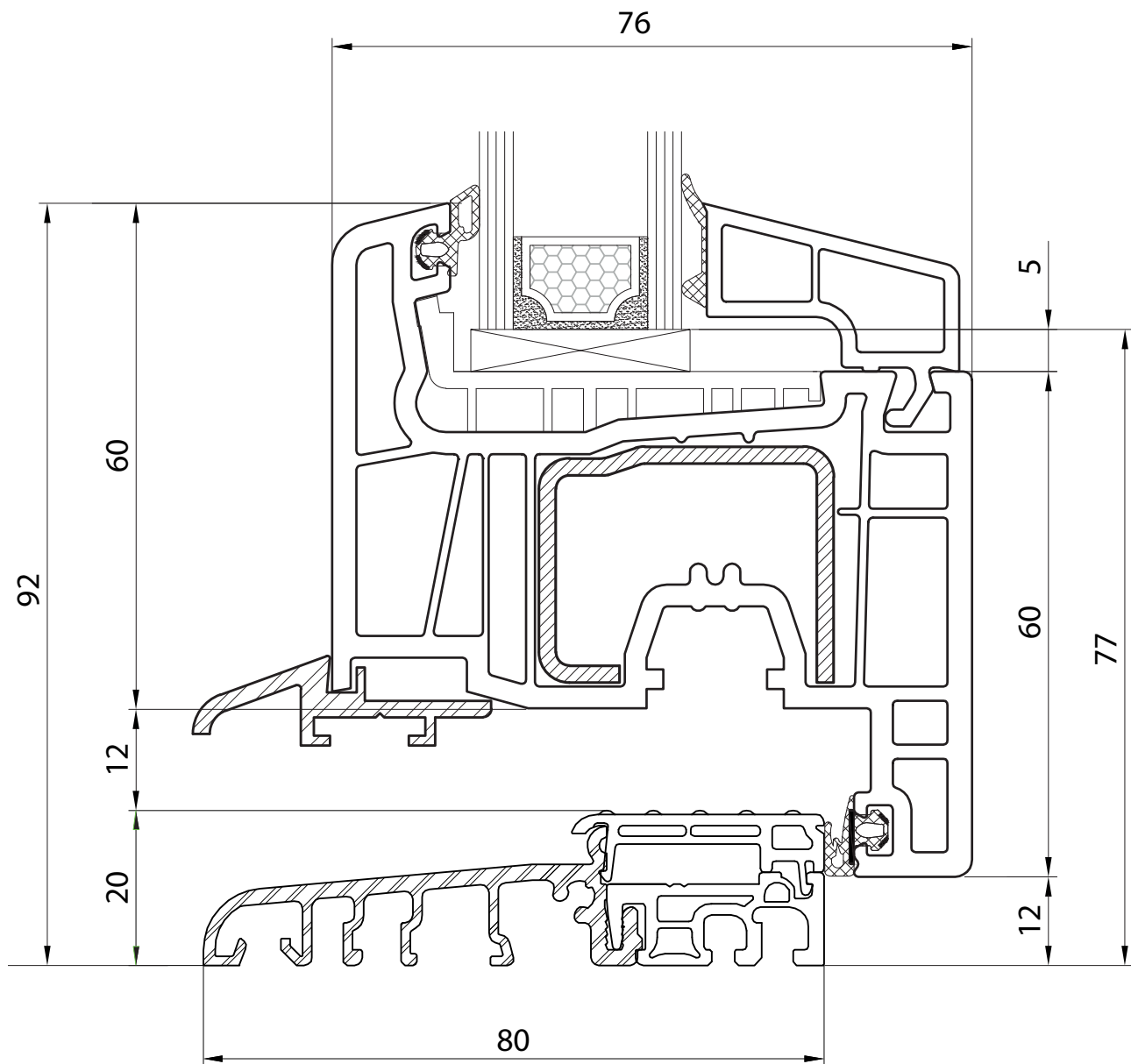

SALAMANDER
WINDOW & DOOR SYSTEMS

Drzwi balkonowe z progiem, Classic-line

Porte-fenêtre avec seuil, Classic-line





Balkon raam met drempel, Classic-line

Balkontür mit Schwelle, Classic-line

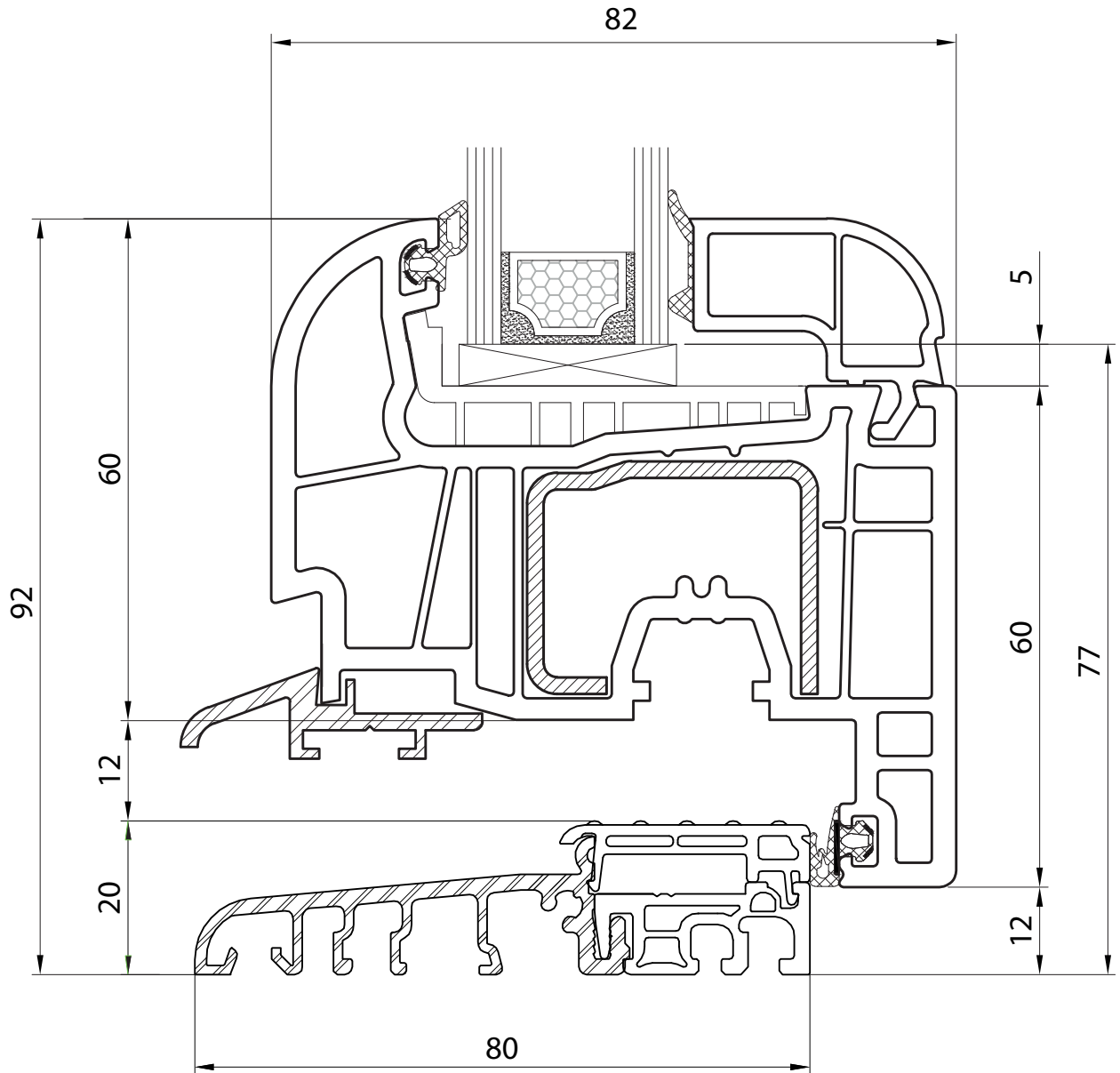
Portafinestra con soglia, Classic-line





-  Drzwi balkonowe z progiem, Round-line
-  Porte-fenêtre avec seuil, Round-line
-  Balkon raam met drempel, Round-line
-  Balkontür mit Schwelle, Round-line
-  Portafinestra con soglia, Round-line









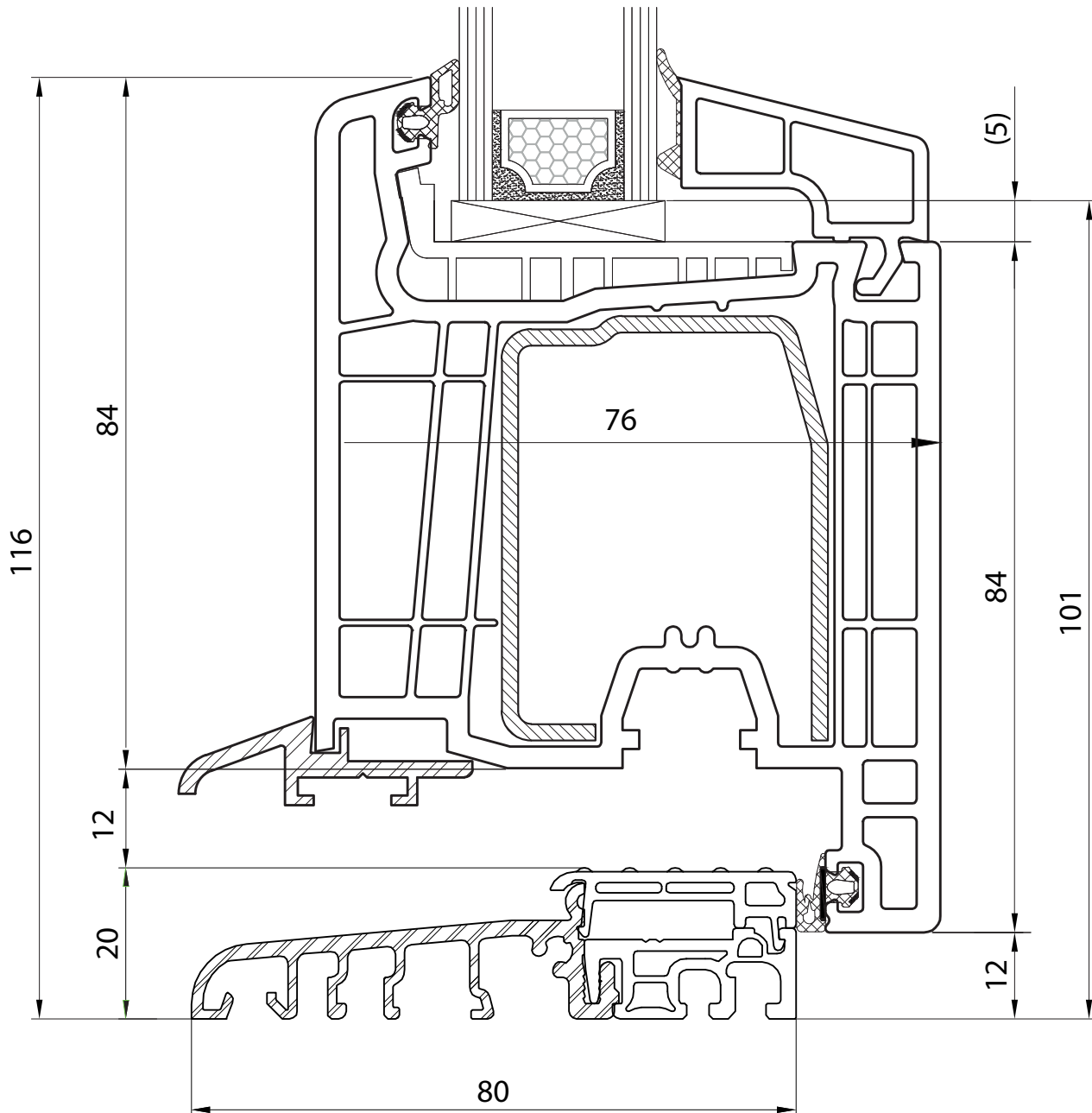

Streamline 76

251 030 - 548 523





**OKO
OKNA**

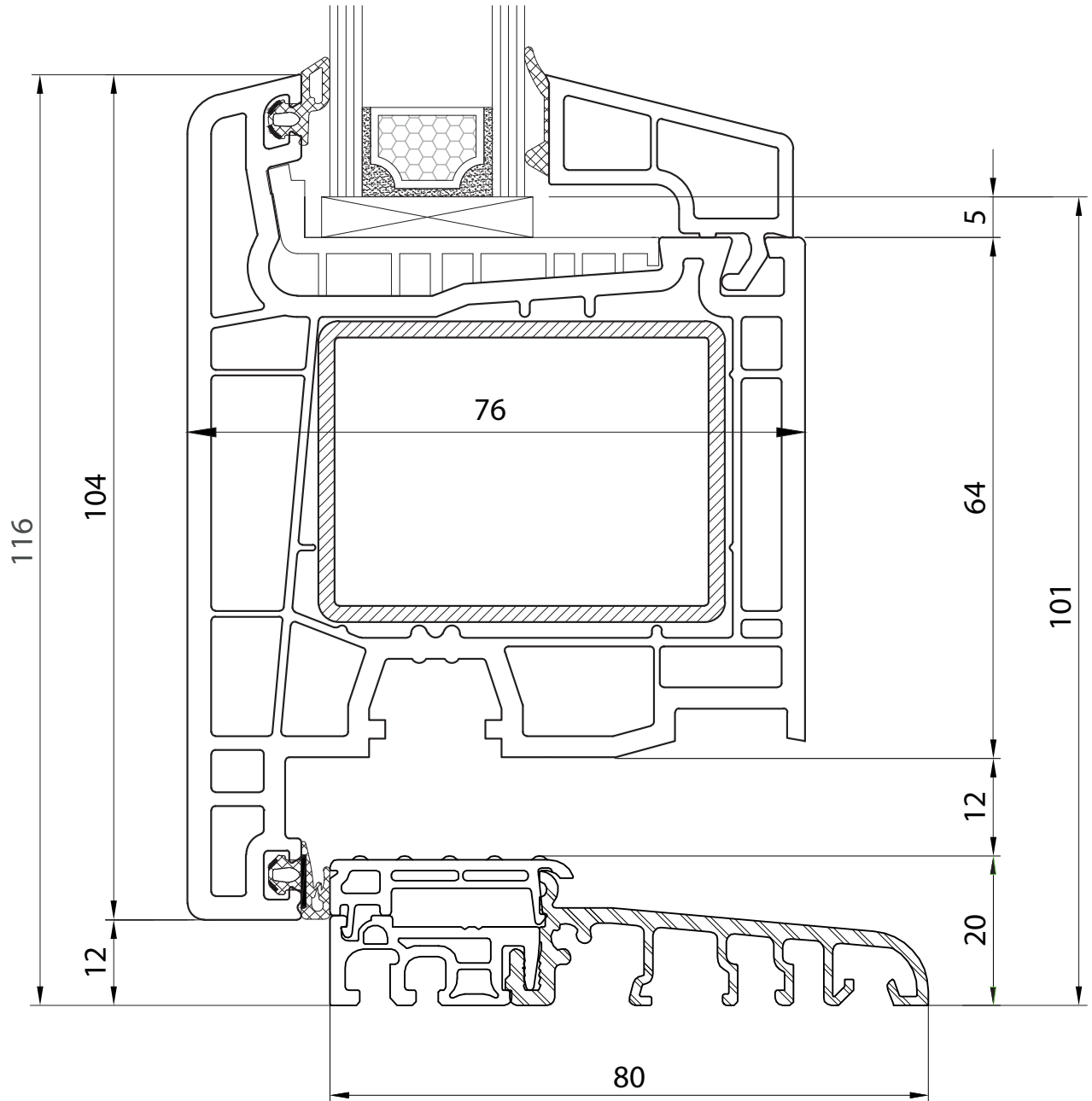

SALAMANDER
WINDOW & DOOR SYSTEMS

- Drzwi tarasowe z progim, otwierane do wewnątrz 
- Profil de passage avec seuil, ouverture vers l'intérieur 
- Terras profiel met drempel, naar binnen opendraaiend 
- Terrassentür mit Schwelle, nach Innen öffnend 
- Portaveranda con soglia, l'apertura verso interno 



-  Drzwi tarasowe z progiem, otwierane na zewnątrz
-  Profil de passage avec seuil, ouverture vers l'extérieur
-  Terras profiel met drempel, naar buiten opendraaiend
-  Terrassentür mit Schwelle, nach Aussen öffnend
-  Portaveranda con soglia, l'apertura verso esterno





Streamline 76

251 040 - 548 523

**OKO
OKNA**

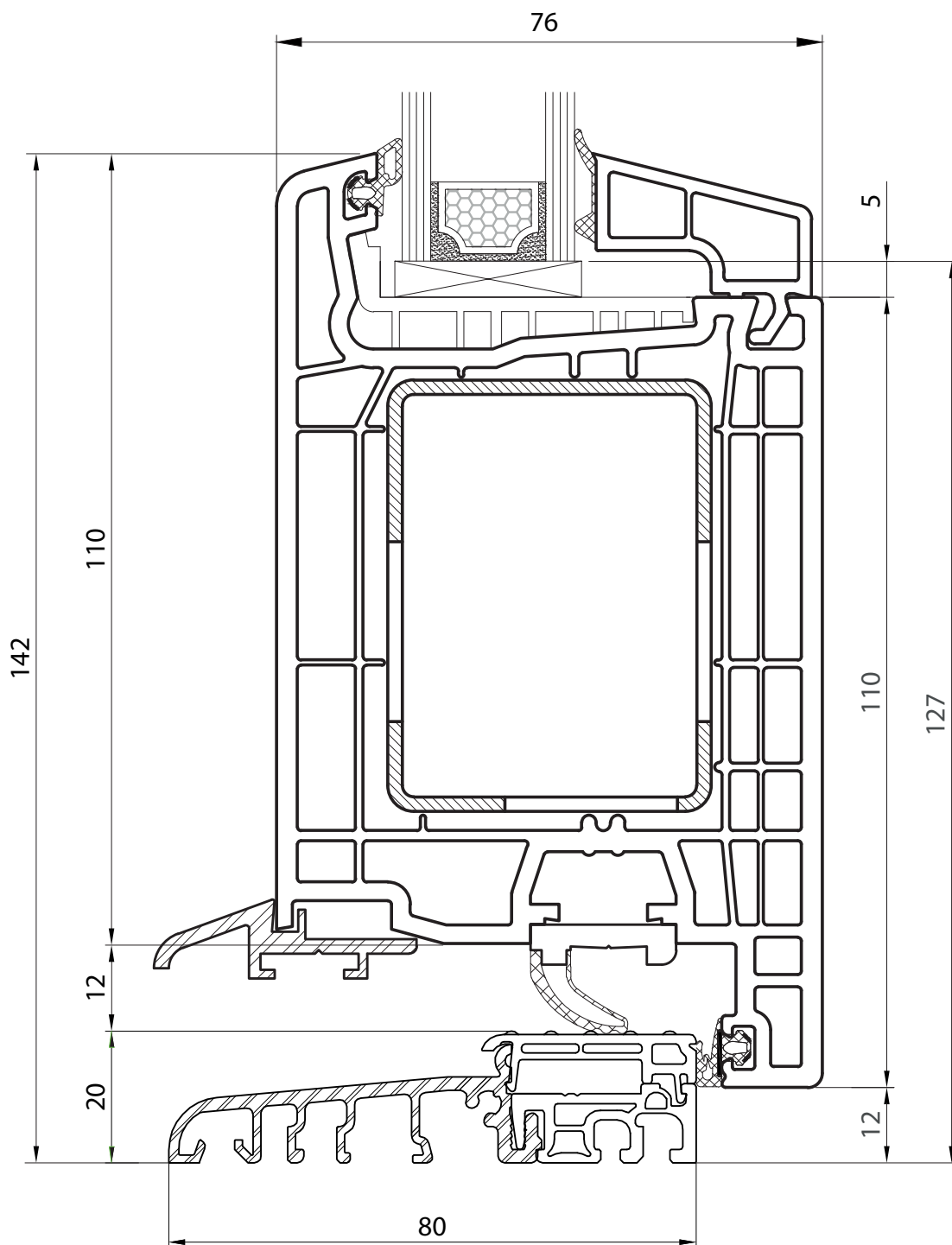

Niski próg, drzwi wejściowe typu A, otwierane do wewnątrz

Coupe du bas, porte d'entrée type A, ouverture vers l'intérieur

Onderste doorsnede, deur versie A, naar binnen opendraaidend

Unterer Querschnitt, Eingangstür Version „A“, nach Innen öffnend

Sezione inferiore, porta d'ingresso la versione „A“, l'apertura verso interno



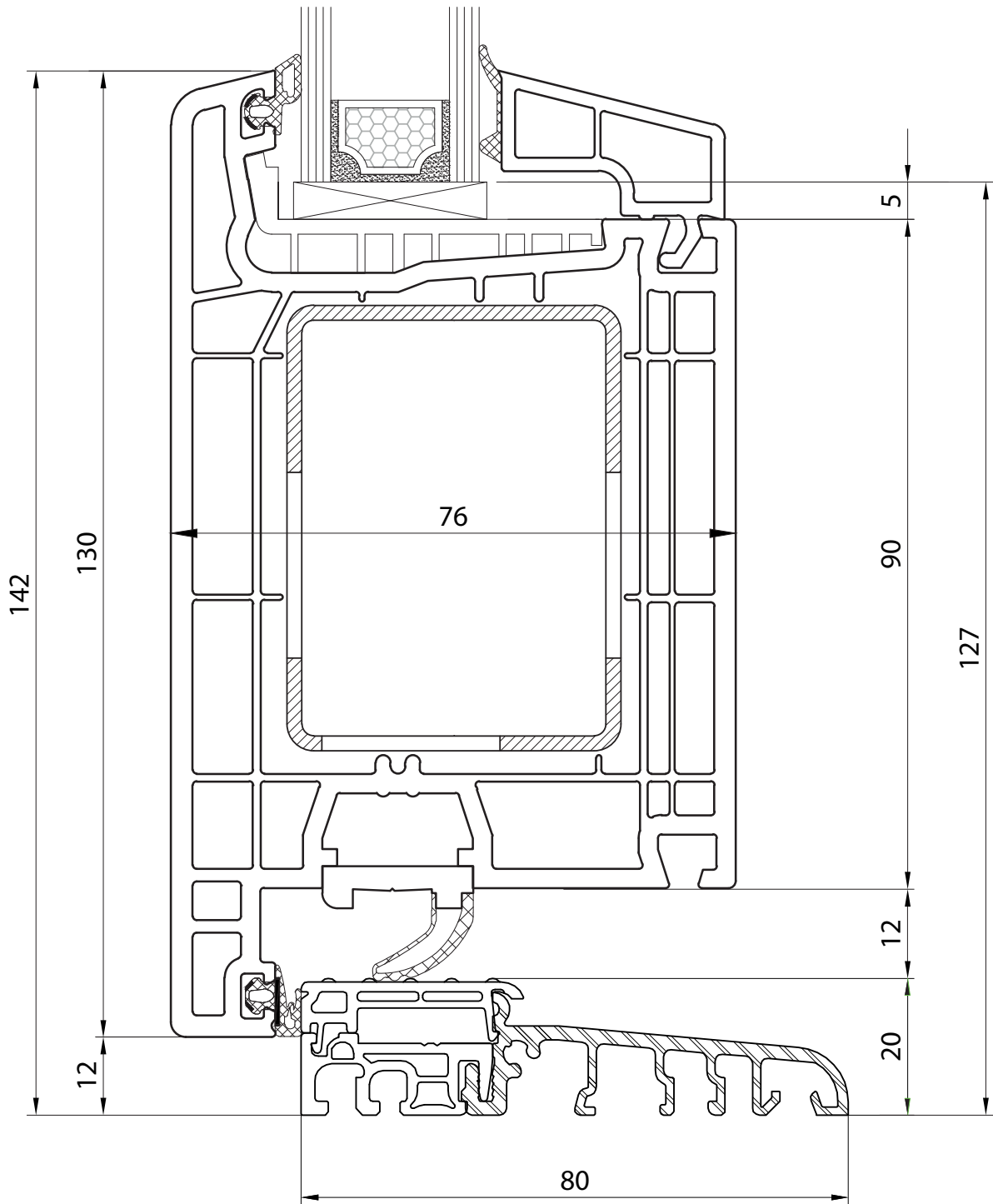
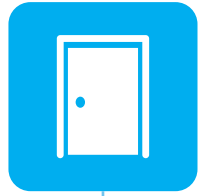

Niski próg, drzwi wejściowe typu A, otwierane na zewnątrz



Coupe du bas, porte d'entrée type A, ouverture vers l'extérieur



Onderste doorsnede, deur versie A, naar buiten opendraaiend



Unterer Querschnitt, Eingangstür Version „A“, nach Aussen öffnend



Sezione inferiore, porta d'ingresso la versione „A“, l'apertura verso esterno



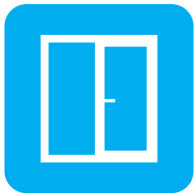

Streamline 76

251 021 - 252 120 - 251 021

OKO
OKNA

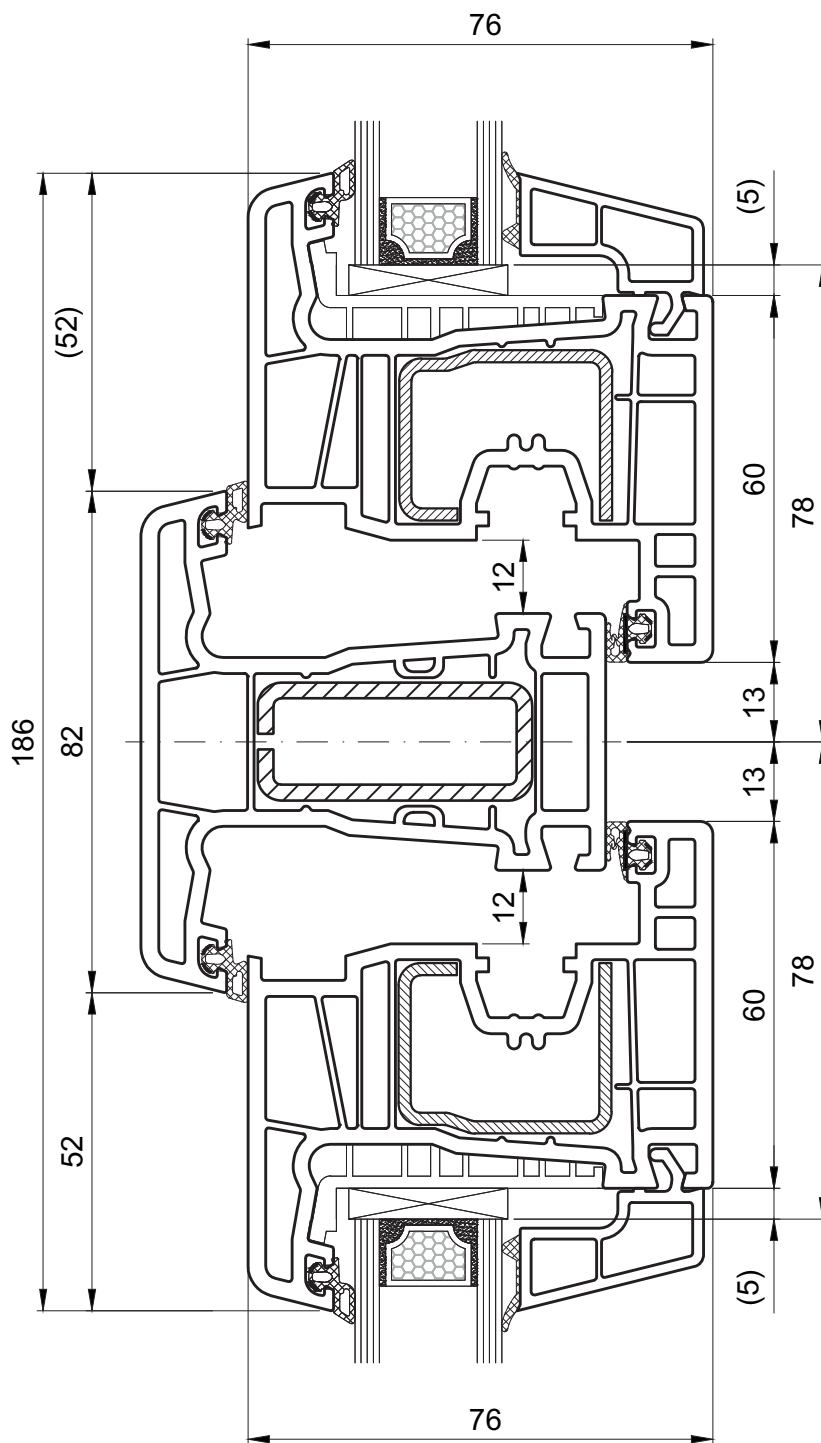

Przekrój przez słupek stały (standard 82 mm) z dwoma skrzydłami okiennymi, Classic-line

Coupe meneau fixe (standard de 82 mm) avec deux ouvrants, Classic-line

Doorsnede, vaste stijl (std 82 mm) met twee vleuels, Classic-line

Längsschnitt fester Pfosten (std 82 mm) mit zwei Flügeln, Classic-line

Sezione del montante fisso (standard 82 mm) con due ante, Classic-line



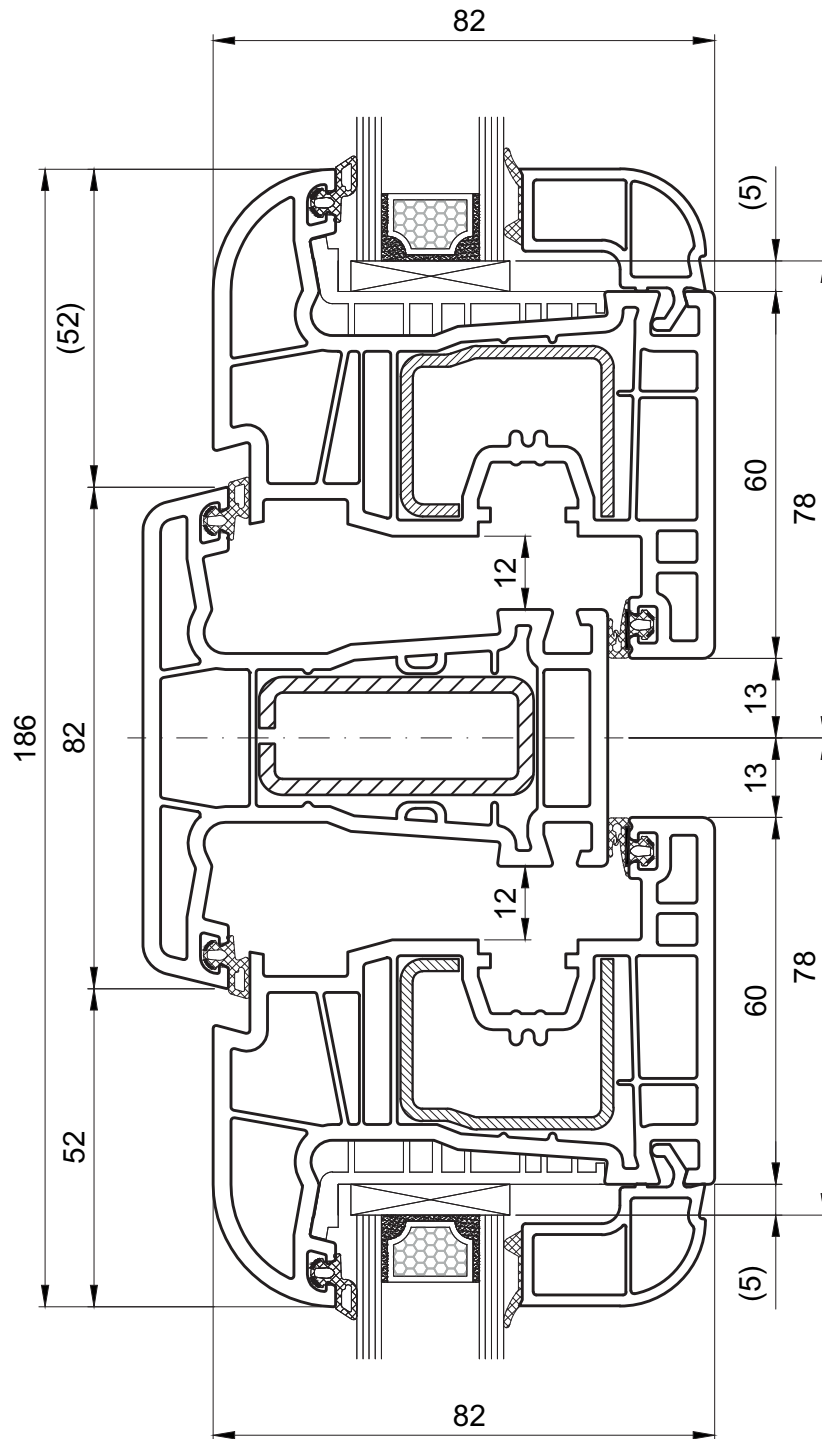

Przekrój przez słupek stały (standard 82 mm) z dwoma skrzydłami okiennymi, Round-line



Coupe meneau fixe (standard de 82 mm) avec deux ouvrants, Round-line



Doorsnede, vaste stijl (std 82 mm) met twee vleugels, Round-line



Längsschnitt fester Pfosten (std 82 mm) mit zwei Flügeln, Round-line



Sezione del montante fisso (standard 82 mm) con due ante, Round-line





Streamline 76

251 030 - 252 120 - 251 030

**OKO
OKNA**

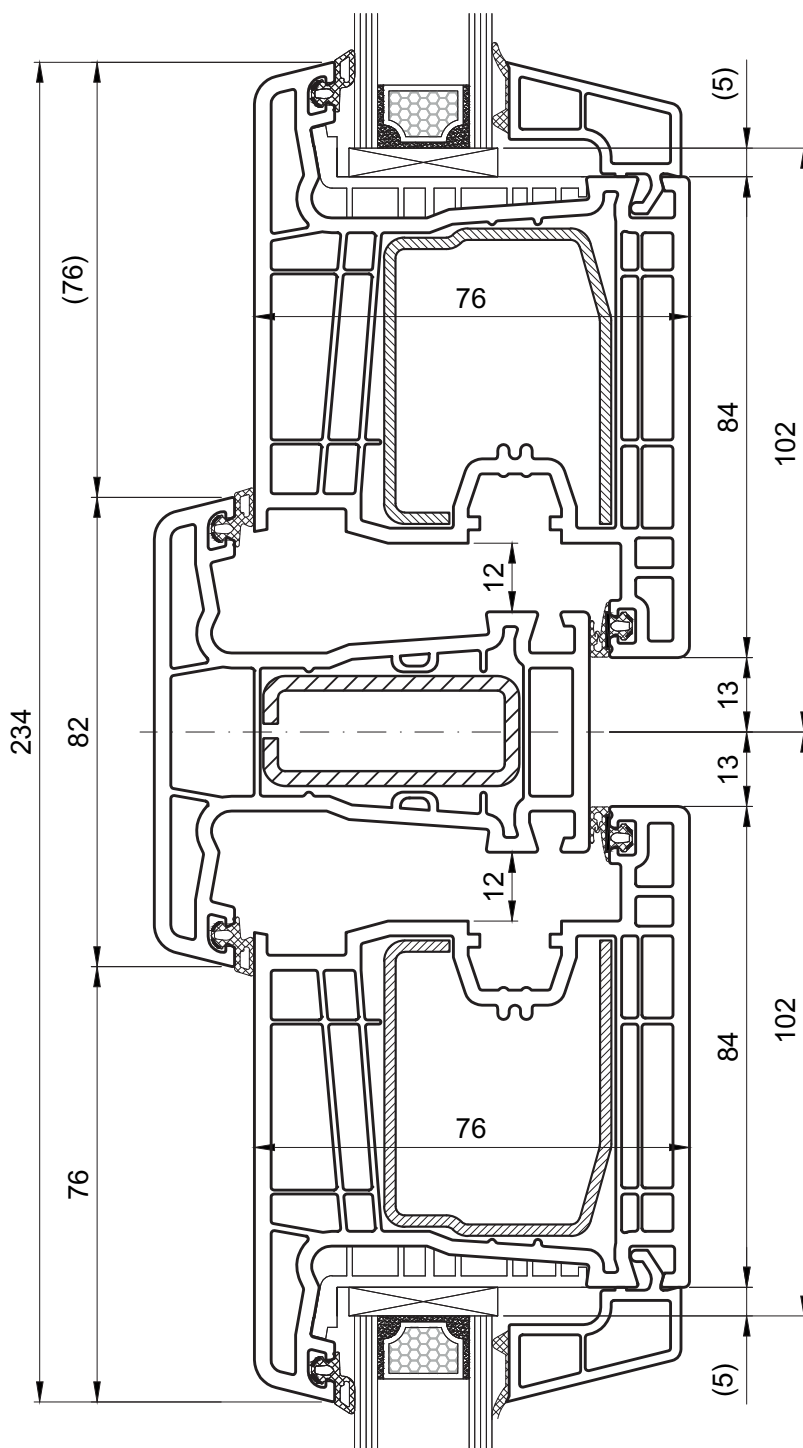

Słupek stały 82 mm z dwoma skrzydłami tarasowymi, otwierane do wewnątrz

Coupe profil de passage, deux ouvrants, ouverture vers l'intérieur avec meneau fixe de 82 mm

Doorsnede terras profiel, twee vleugels naar binnen opendraaiend met vaste stijl 82 mm

Längsschnitt Terrassentür mit zwei Flügeln, nach Innen öffnend mit festem Pfahl 82 mm

Sezione della portaveranda a due ante, l'apertura verso interno con montante fisso 82 mm



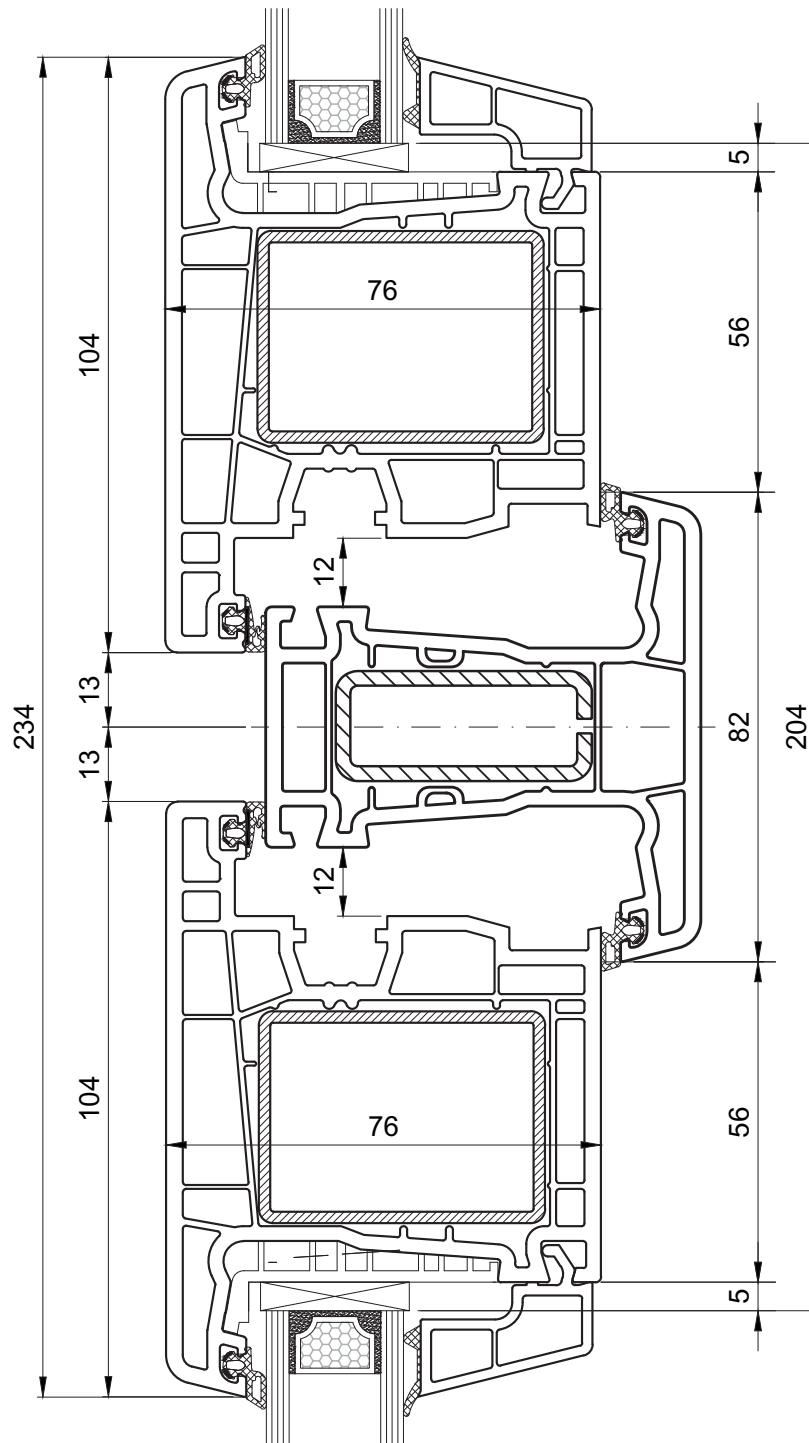

Słupek stały 82 mm z dwoma skrzydłami tarasowymi, otwierane na zewnątrz



Coupe profil de passage, deux ouvrants, ouverture vers l'extérieur avec meneau fixe de 82 mm



Doorsnede terras profiel, twee vleugels naar buiten opendraaiend met vaste stijl 82 mm



Querschnitt Terrassentür mit zwei Flügeln, nach Aussen öffnend mit festem Pfahl 82 mm



Sezione della portaveranda a due ante, l'apertura verso esterno con montante fisso 82 mm





Streamline 76

251 040 - 252 120 - 251 040

**OKO
OKNA**

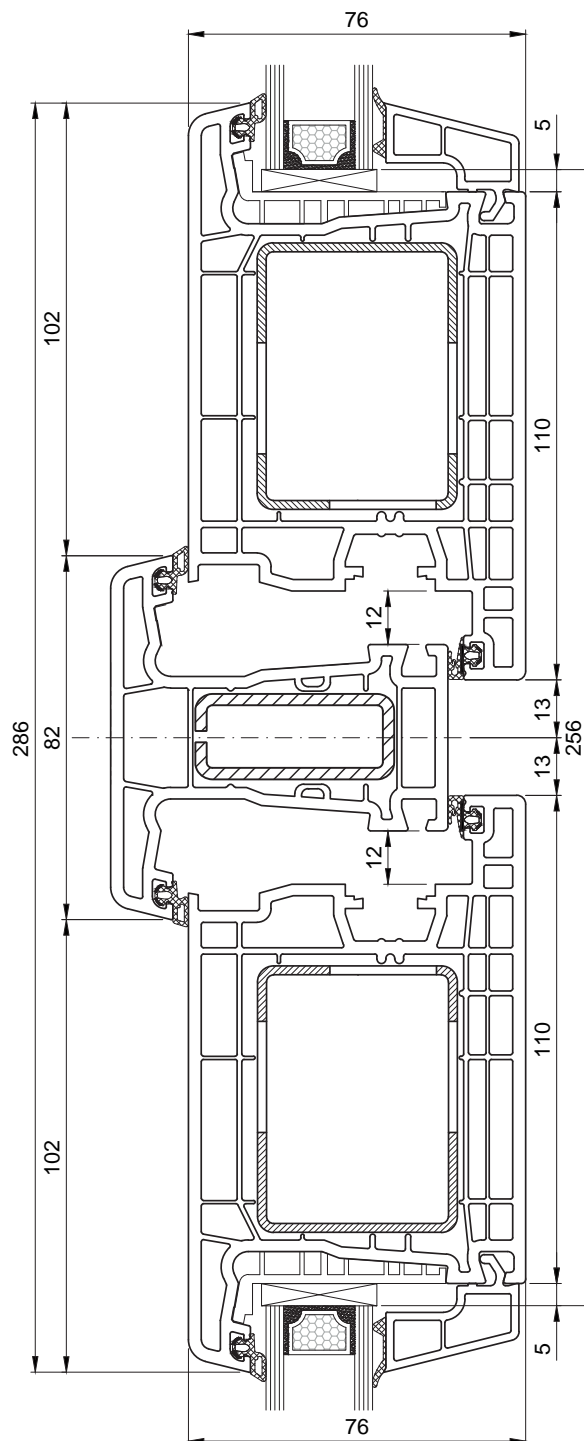

Słupek stały 82 mm z dwoma skrzydłami drzwiowymi, otwierane do wewnątrz

Deux ouvrants de porte avec meneau fixe de 82 mm, ouverture vers l'intérieur

Twee deur vleugels met vaste stijl 82 mm, naar binnen opendraaiend

Zwei Türflügel mit festem Pfahl 82 mm, nach Innen öffnend

Porta a due ante con montante fisso 82 mm, l'apertura verso interno



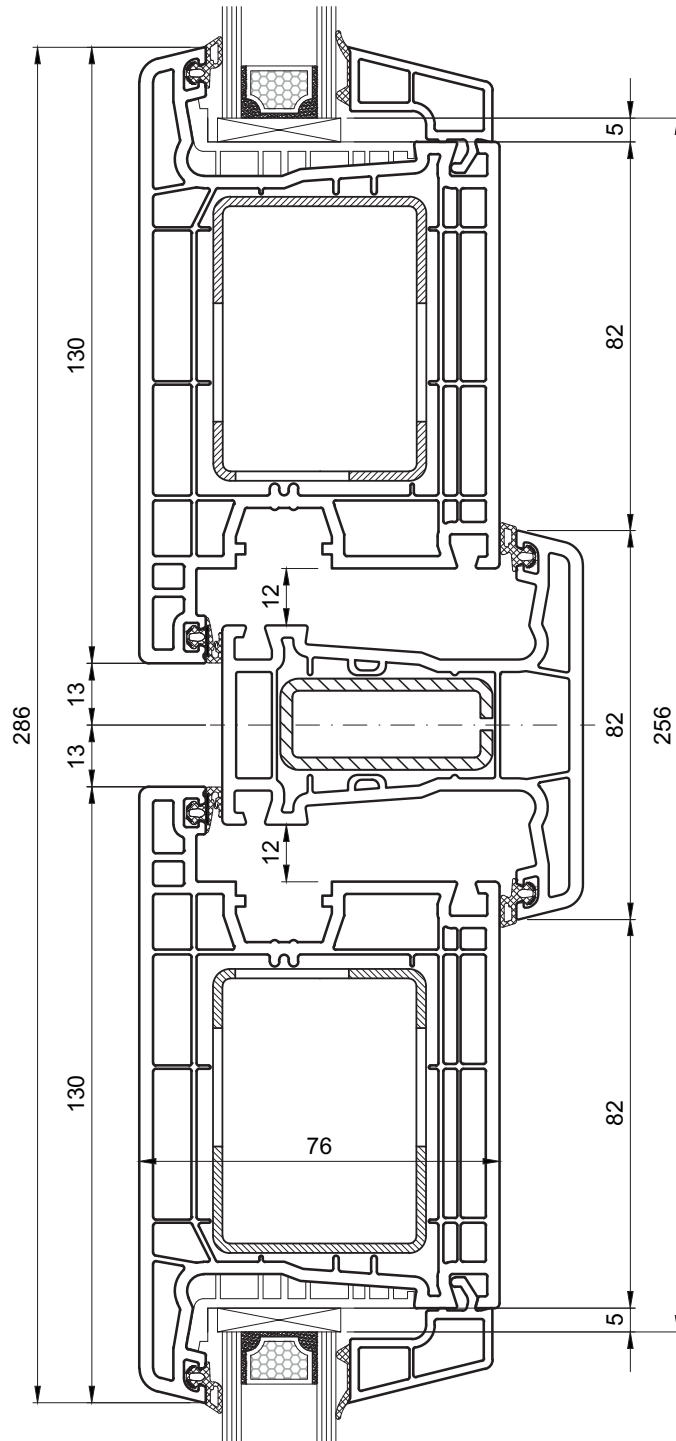

Słupek stały 82 mm z dwoma skrzydłami drzwiowymi, otwierane na zewnątrz



Deux ouvrants de porte avec meneau fixe de 82 mm, ouverture vers l'extérieur



Twee deur vleugels met vaste stijl 82 mm, naar buiten opendraaiend



Zwei Türflügel mit festem Pfahl 82 mm, nach Aussen öffnend



Porta a due ante con montante fisso 82 mm, l'apertura verso esterno



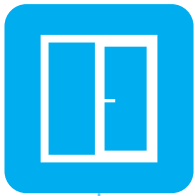

Streamline 76

252 120

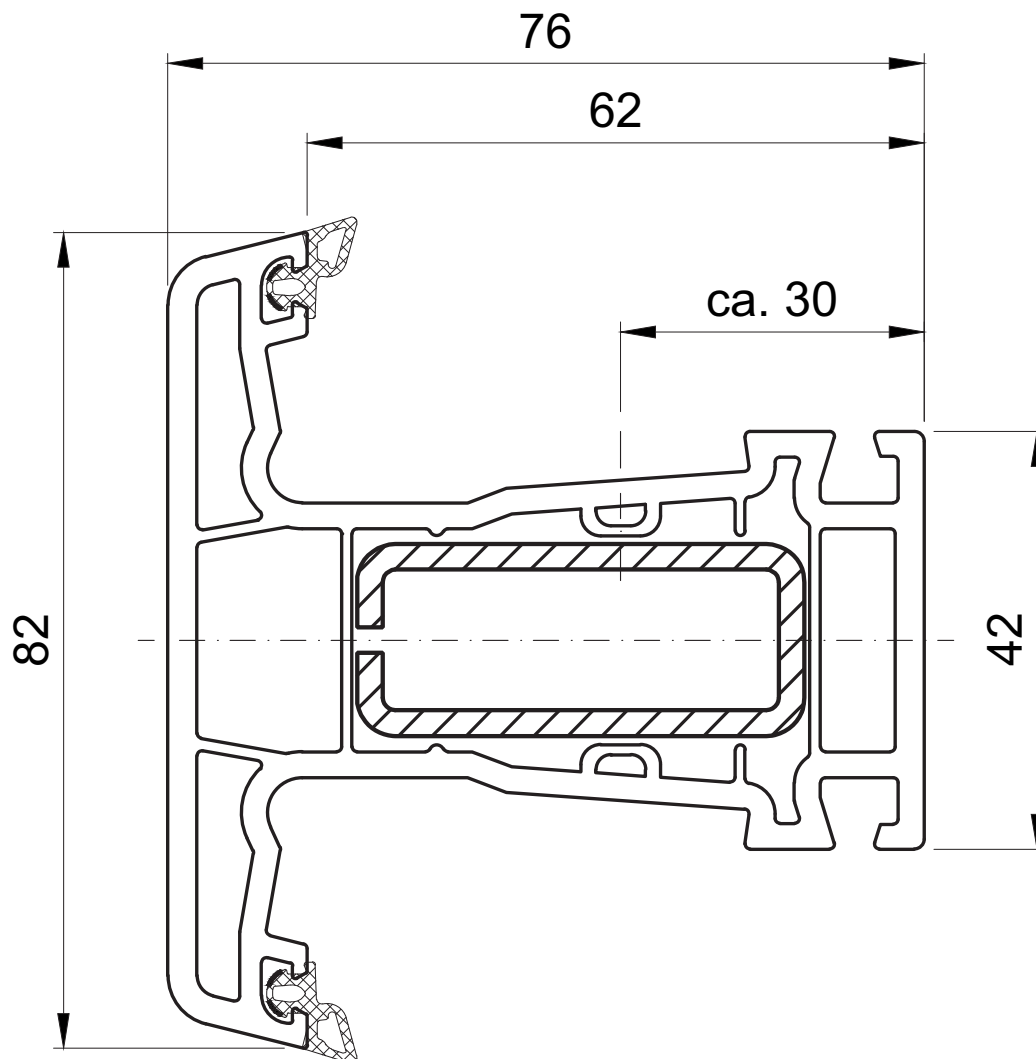

SALAMANDER
WINDOW & DOOR SYSTEMS

Słupki stały - standard 82 mm



Meneau standard de 82 mm



Standaard stijl 82 mm



Fester Pfosten standard 82 mm



Montante standard 82 mm



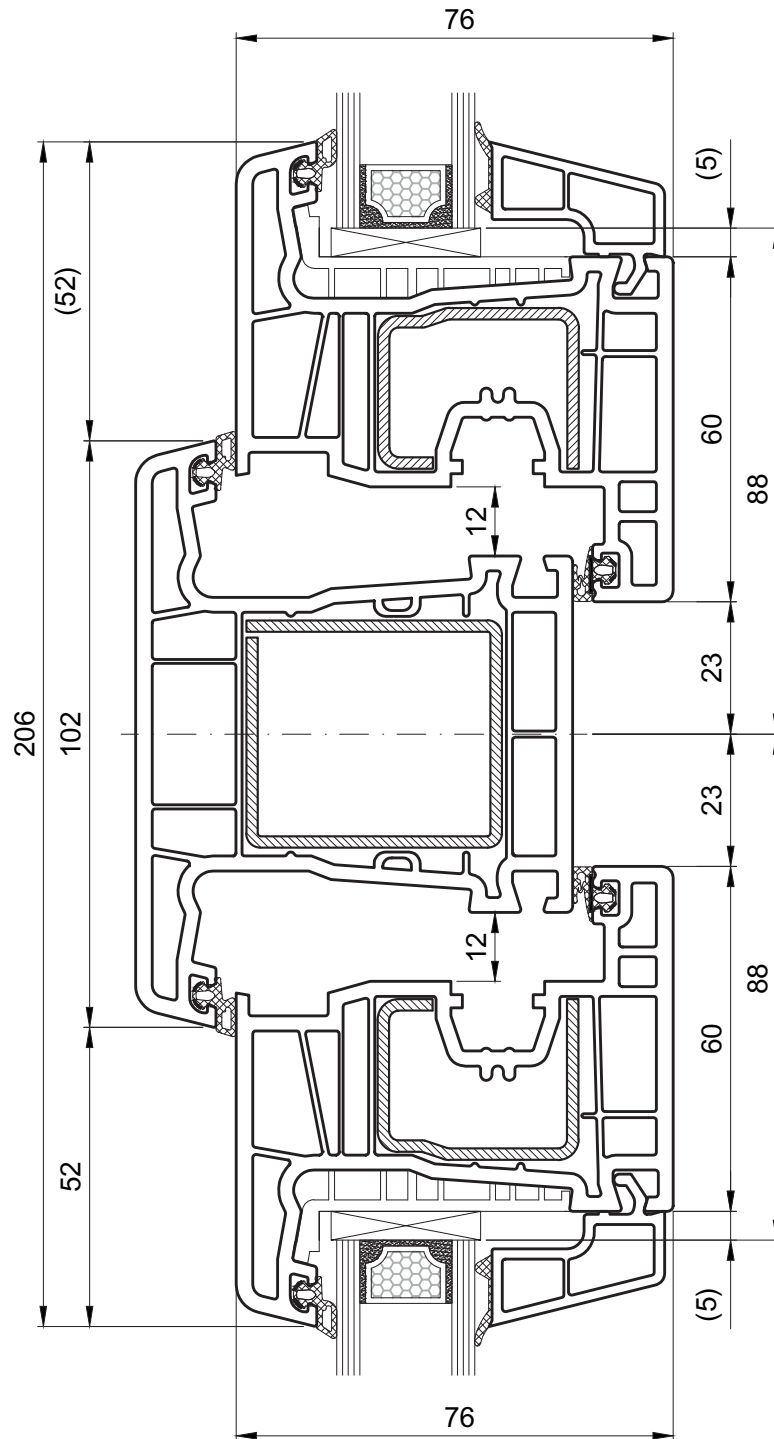

Słupek stały 102 mm z dwoma skrzydłami okiennymi Classic-line



Assemblage de deux ouvrants de fenêtre Classic-line avec meneau large de 102 mm



Aansluiting van twee raam vleugels Classic-line met brede stijl 102 mm



Verbunden mit Hilfe eines breiten Pfostens mit 102 mm Breite



Guinzione di due ante finestra Classic-line con montante 102 mm



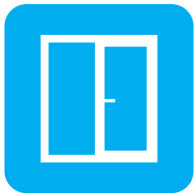

Streamline 76

251 221 - 252 130 - 251 221

OKO
OKNA

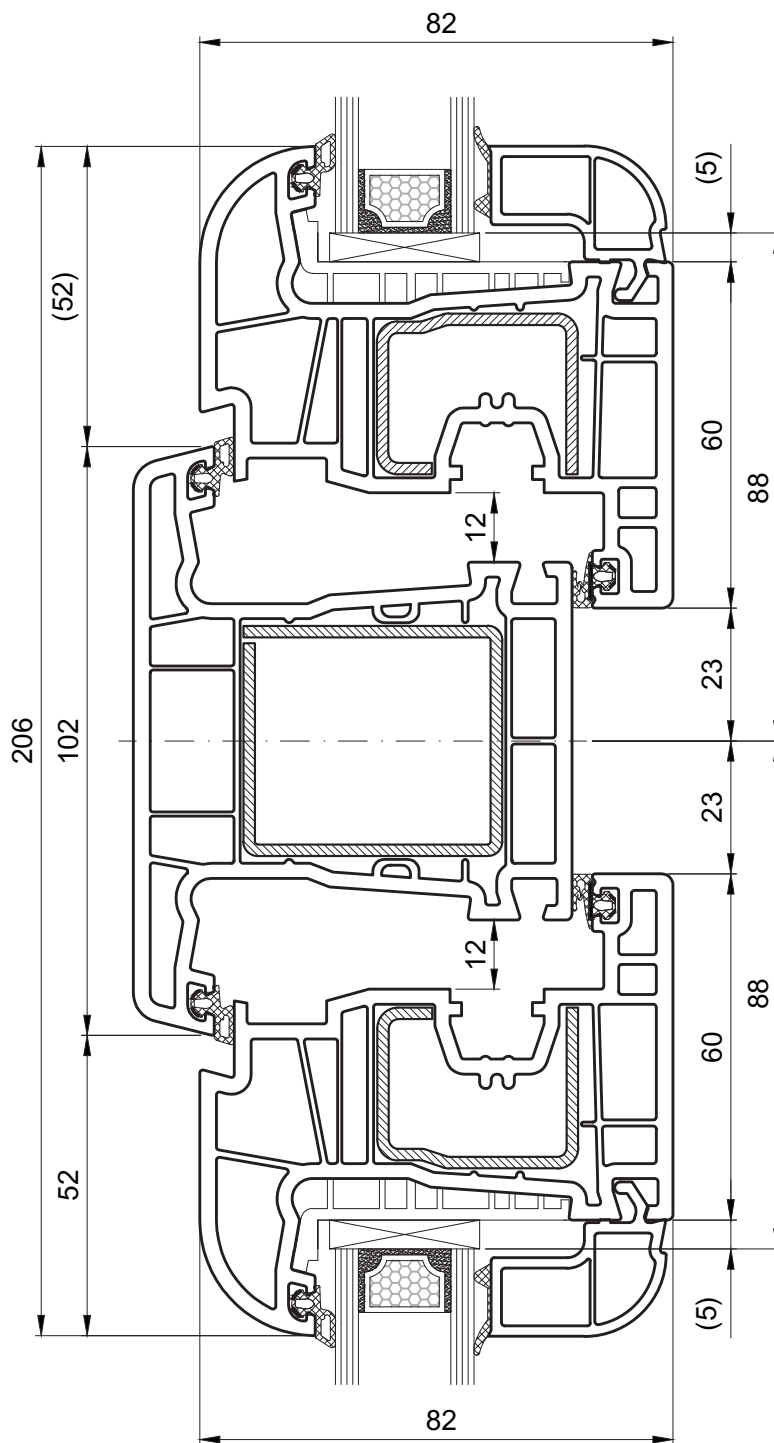

Słupek stały 102 mm z dwoma skrzydłami okiennymi Round-line

Coupe de deux ouvrants de fenêtre Round-line avec meneau large de 102 mm

Aansluiting van twee raam vleugels Round-line met brede stijl 102 mm

Zwei Fensterflügel Round-line verbunden mit Hilfe eines breiten Pfostens mit 102 mm Breite

Guinzione di due ante finestra Round-line con montante 102 mm



SALAMANDER
WINDOW & DOOR SYSTEMS



Streamline 76

351 030 - 252 130 - 351 030

**OKO
OKNA**

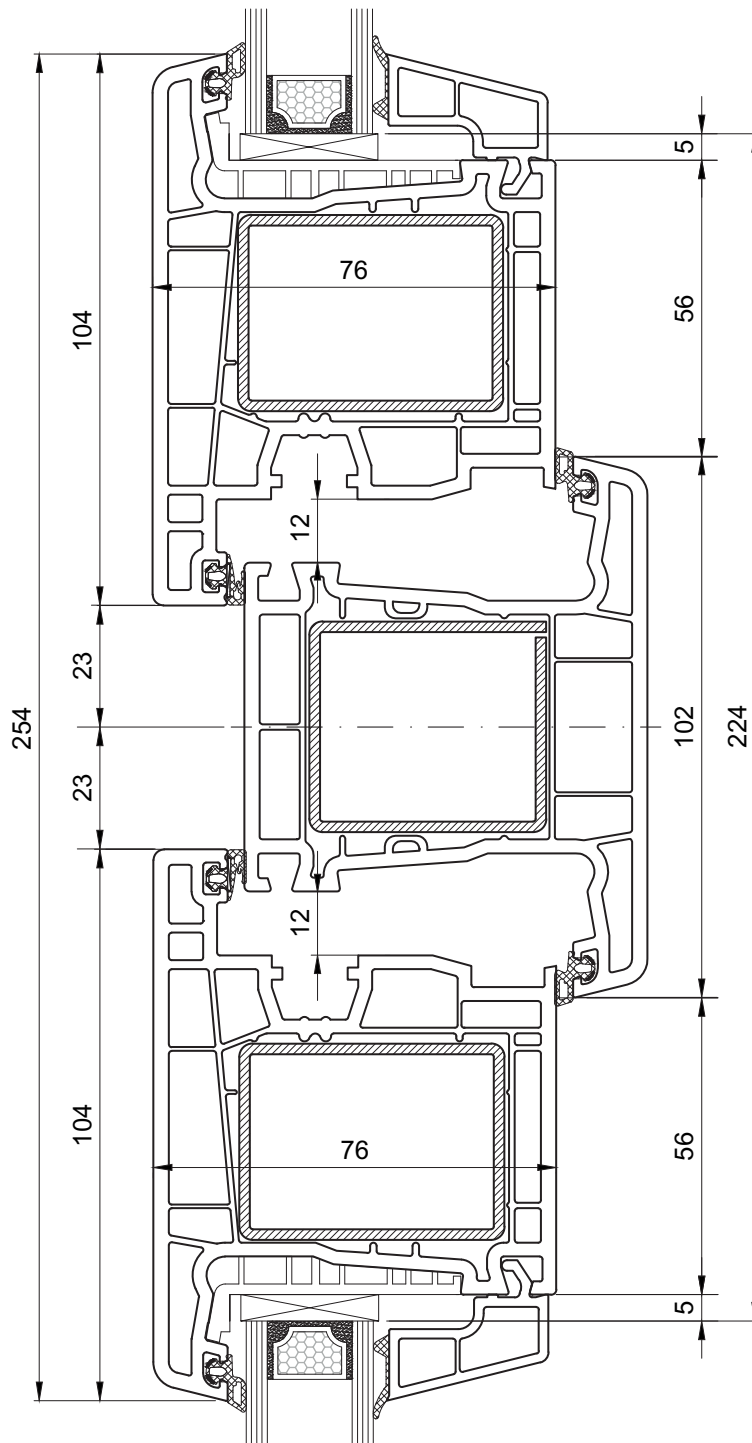

Słupek stały 102 mm z dwoma skrzydłami tarasowymi, otwierane na zewnątrz

Coupe de deux ouvrants de porte de passage avec meneau large de 102 mm, ouverture vers l'extérieur

Aansluiting van twee terras vleugels met brede stijl 102 mm, naar buiten opendraaiend

Zwei Terrassenflügel verbunden mit Hilfe eines breiten Pfosten mit 102 mm Breite nach Aussen öffnend

Guinzione di due ante portaverande con montante 102 mm, l'apertura verso esterno



SALAMANDER
WINDOW & DOOR SYSTEMS

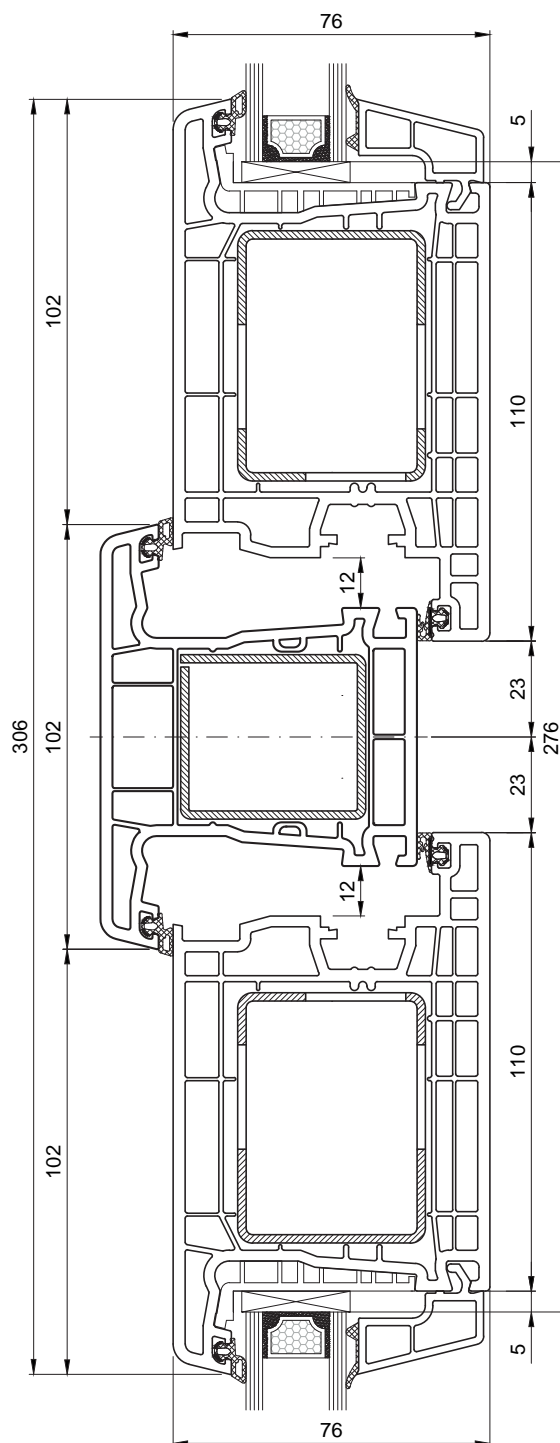

Słupek stały 102 mm z dwoma skrzydłami drzwiowymi, otwierane do wewnątrz



Coupe de deux ouvrants de porte, meneau large de 102 mm, ouverture vers l'intérieur



Aansluiting van twee deur vleugels met brede stijl 102 mm, naar binnen opendraaiend



Zwei Türflügel verbunden mit Hilfe eines nach Innen öffnend breiten Pfosten mit 102 mm Breite



Guinzione di due ante della porta con montante 102 mm, l'apertura verso interno





Streamline 76

351 040 - 252 130 - 351 040

**OKO
OKNA**

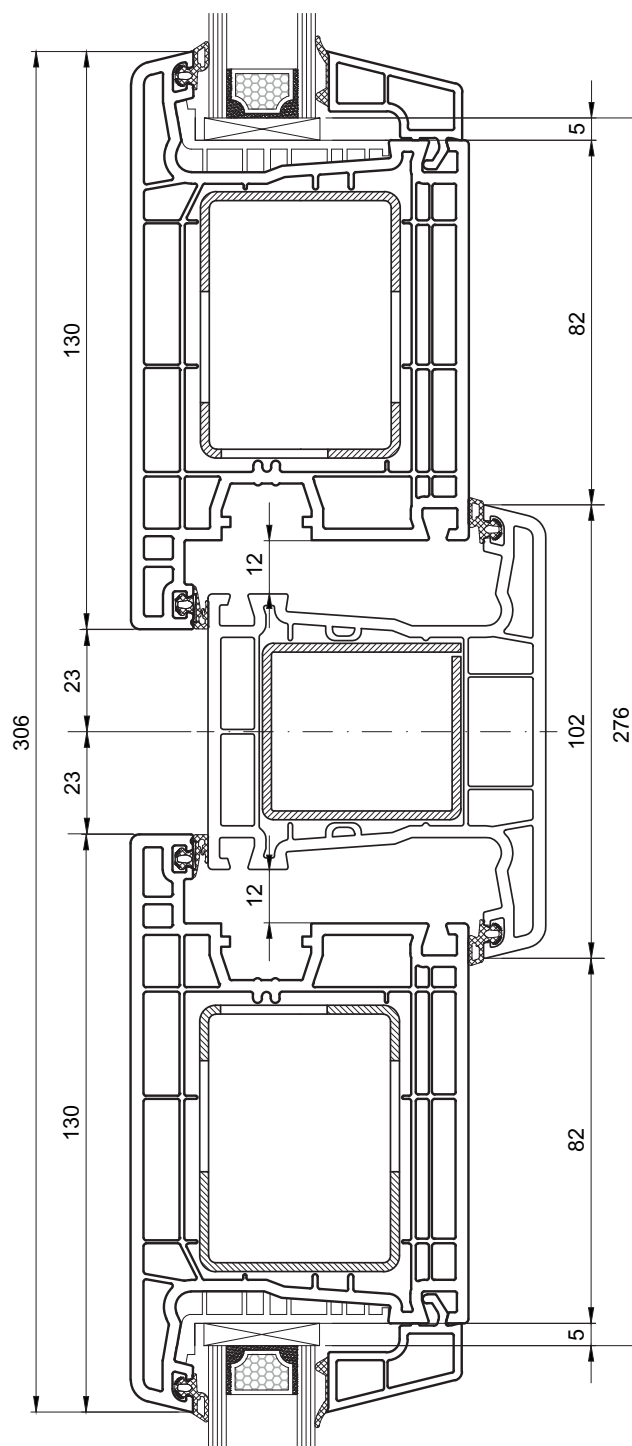

Słupek stały 102 mm z dwoma skrzydłami drzwiowymi, otwierane na zewnątrz

Coupe de deux ouvrants de porte avec meneau large de 102 mm, ouverture vers l'extérieur

Aansluiting van twee deur vleugels met brede stijl 102 mm, naar buiten opendraaiend

Zwei Türflügel verbunden mit Hilfe eines breiten Pfosten mit 102 mm Breite nach Aussen öffnend

Guinzione di due ante porta con montante 102 mm, l'apertura verso esterno



SALAMANDER
WINDOW & DOOR SYSTEMS

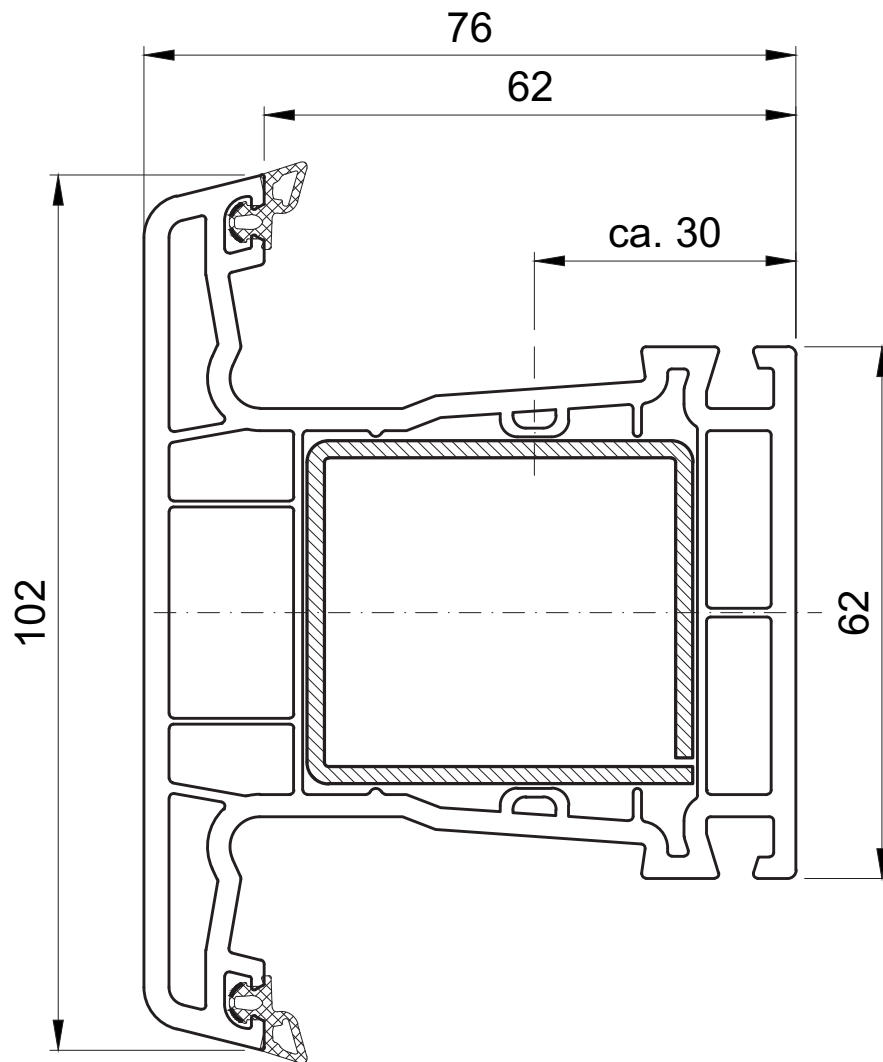

-  Słupek stały 102 mm
-  Meneau large de 102 mm
-  Brede stijl 102 mm
-  Breiter Pfosten mit 102 mm
-  Montante 102 mm



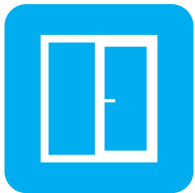

Streamline 76

251 021 - 256 030 - 251 021

OKO
OKNA

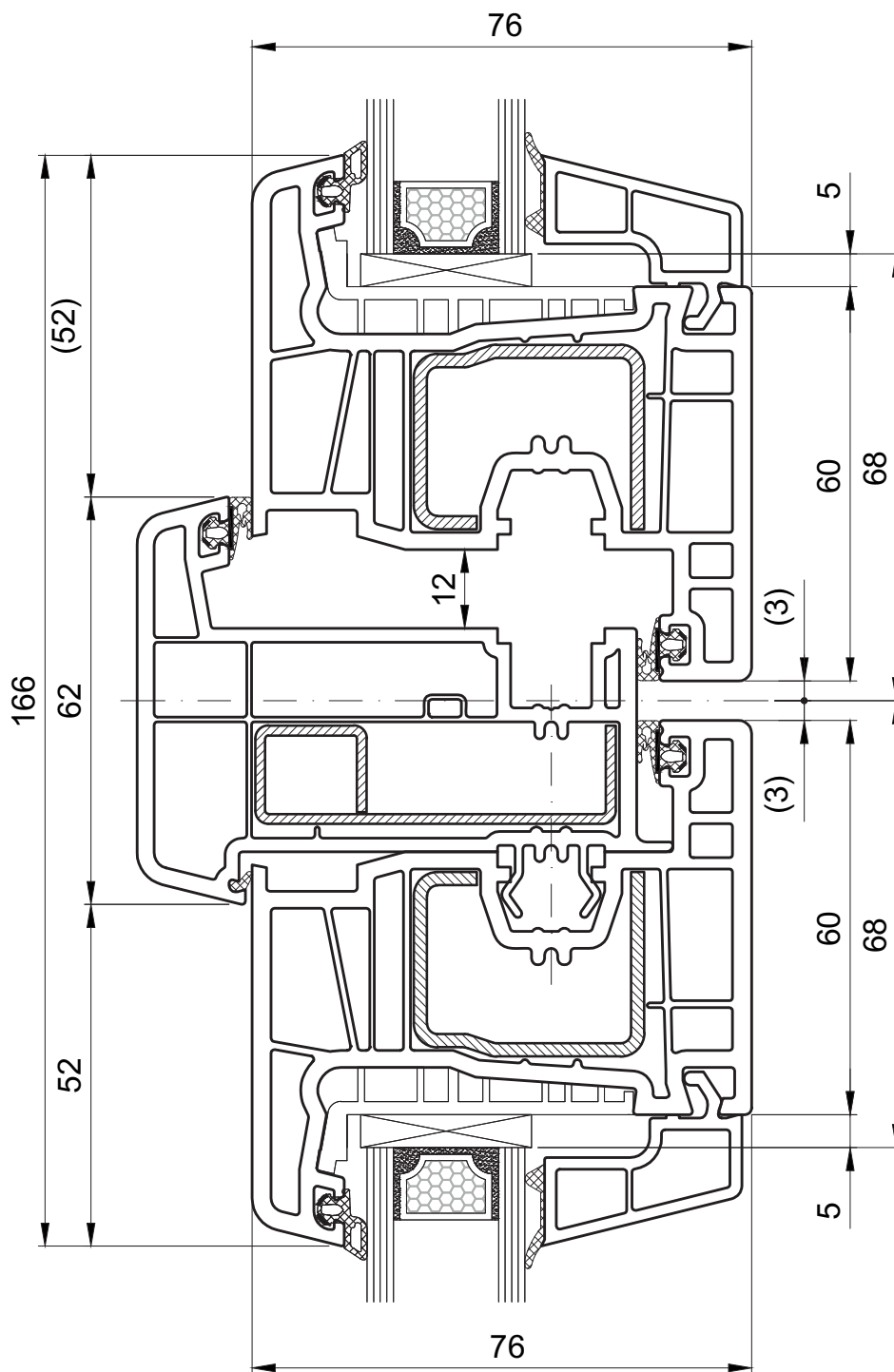

Słupek ruchomy 62 mm z dwoma skrzydłami okiennymi Classic-line

Coupe de deux ouvrants Classic-line avec meneau mobile de 62 mm

Aansluiting van twee raam vleugels Classic-line met brede stijl 62 mm

Zwei Flügel Classic-line verbunden mit Hilfe eines breiten Stulps mit 62 mm Breite

Guinzione di due ante Classic-line, montante mobile 62 mm



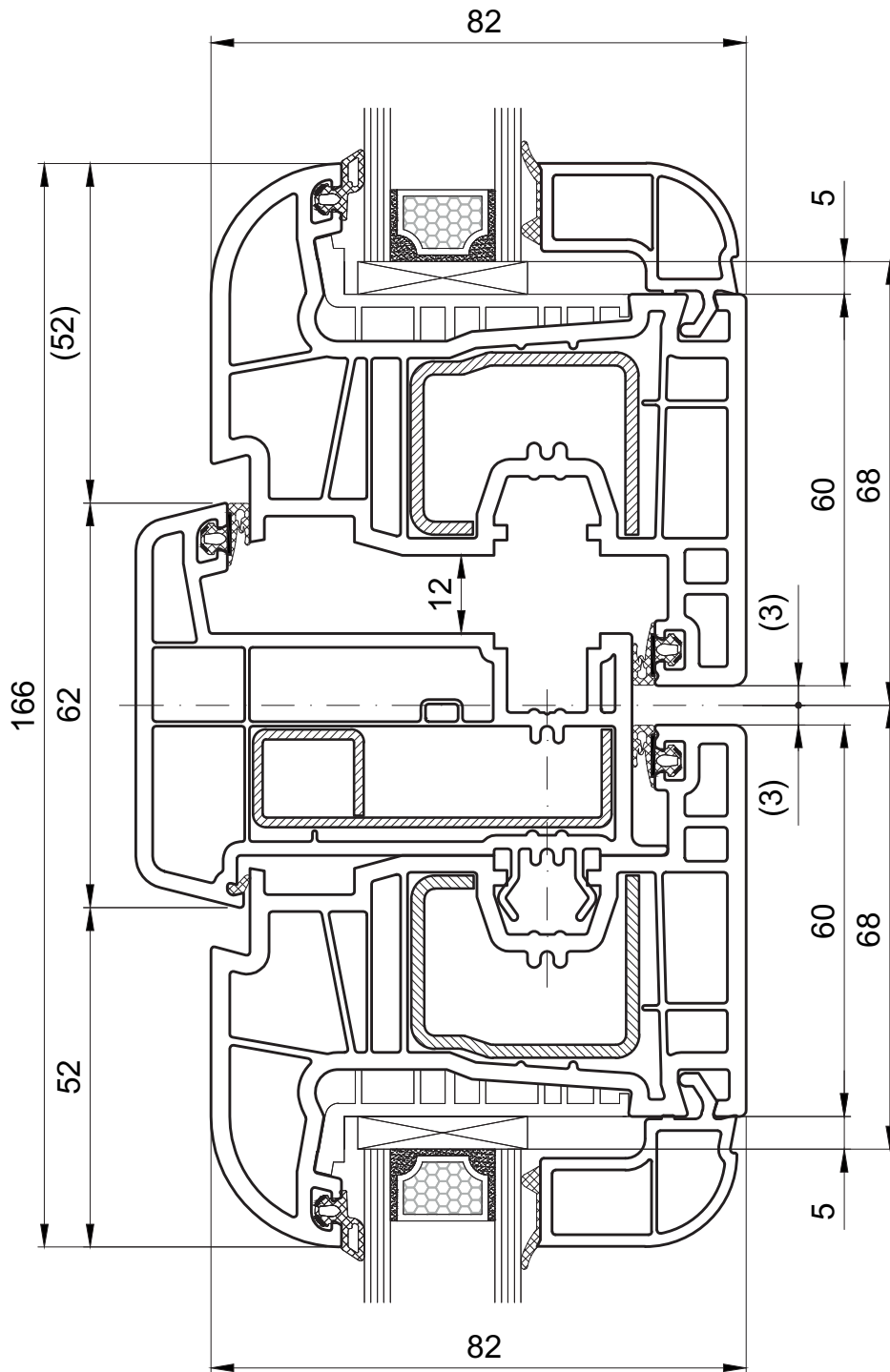

Słupek ruchomy 62 mm z dwoma skrzydłami okiennymi Round-line



Coupe de deux ouvrants Round-line avec meneau mobile de 62 mm



Aansluiting van twee raam vleugels Round-line met brede stijl 62 mm



Zwei Flügel Round-line verbunden mit Hilfe eines breiten Stulps mit 62 mm Breite



Guinzione di due ante Round-line con montante mobile 62 mm





Streamline 76

251 030 - 256 030 - 251 030

**OKO
OKNA**

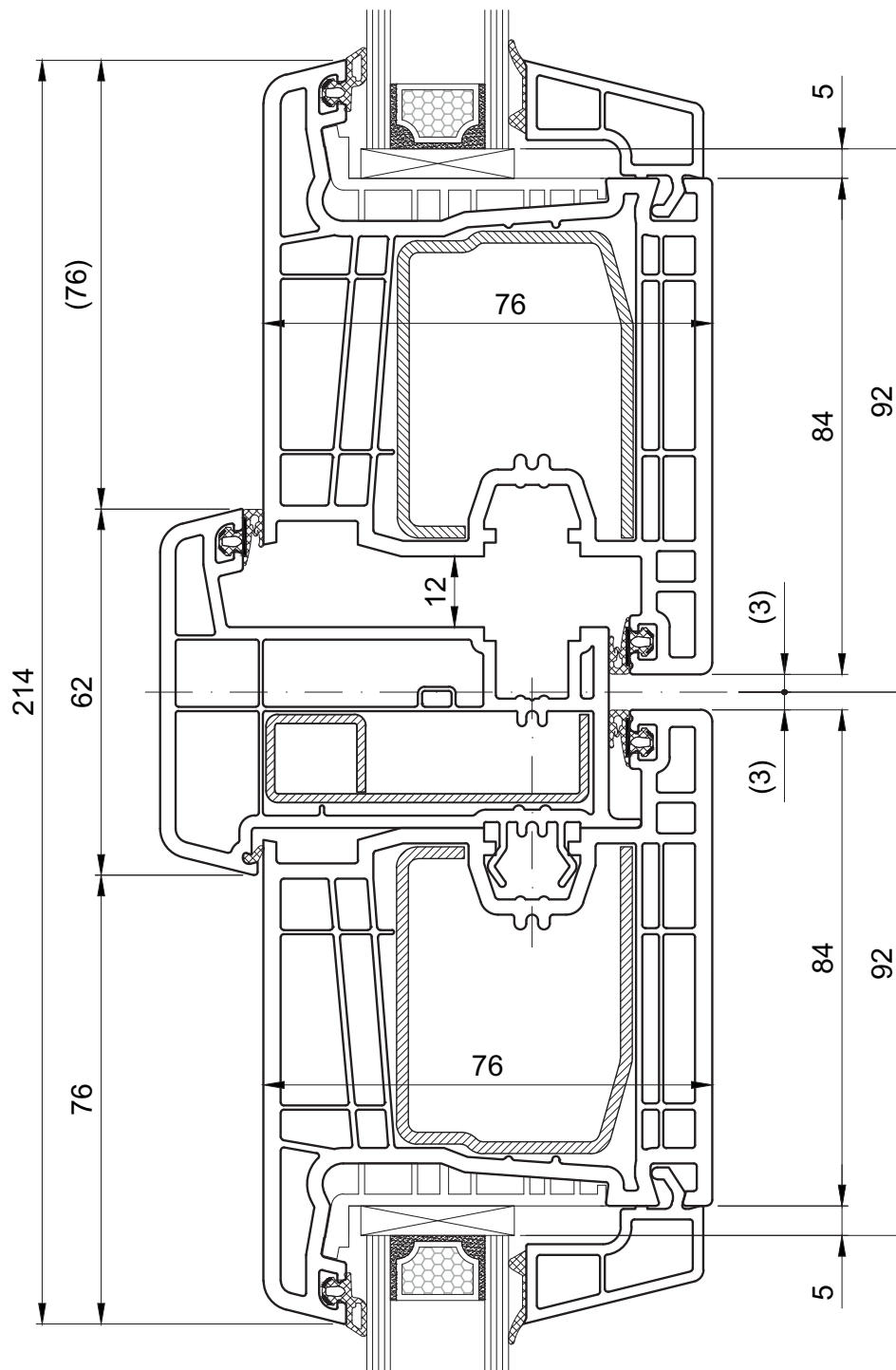

Słupek ruchomy 62 mm z dwoma skrzydłami tarasowymi, otwierane do wewnątrz

Coupe de deux ouvrants de porte de passage avec meneau mobile de 62 mm, ouverture vers l'intérieur

Aansluiting van twee terras vleugels met brede stijl 62 mm, naar binnen opendraaiend

Zwei Terrassenflügel verbunden mit Hilfe eines breiten Stulps mit 62 mm Breite, nach Innen öffnend

Guinzione di due ante portaverande con montante mobile 62 mm, l'apertura verso interno



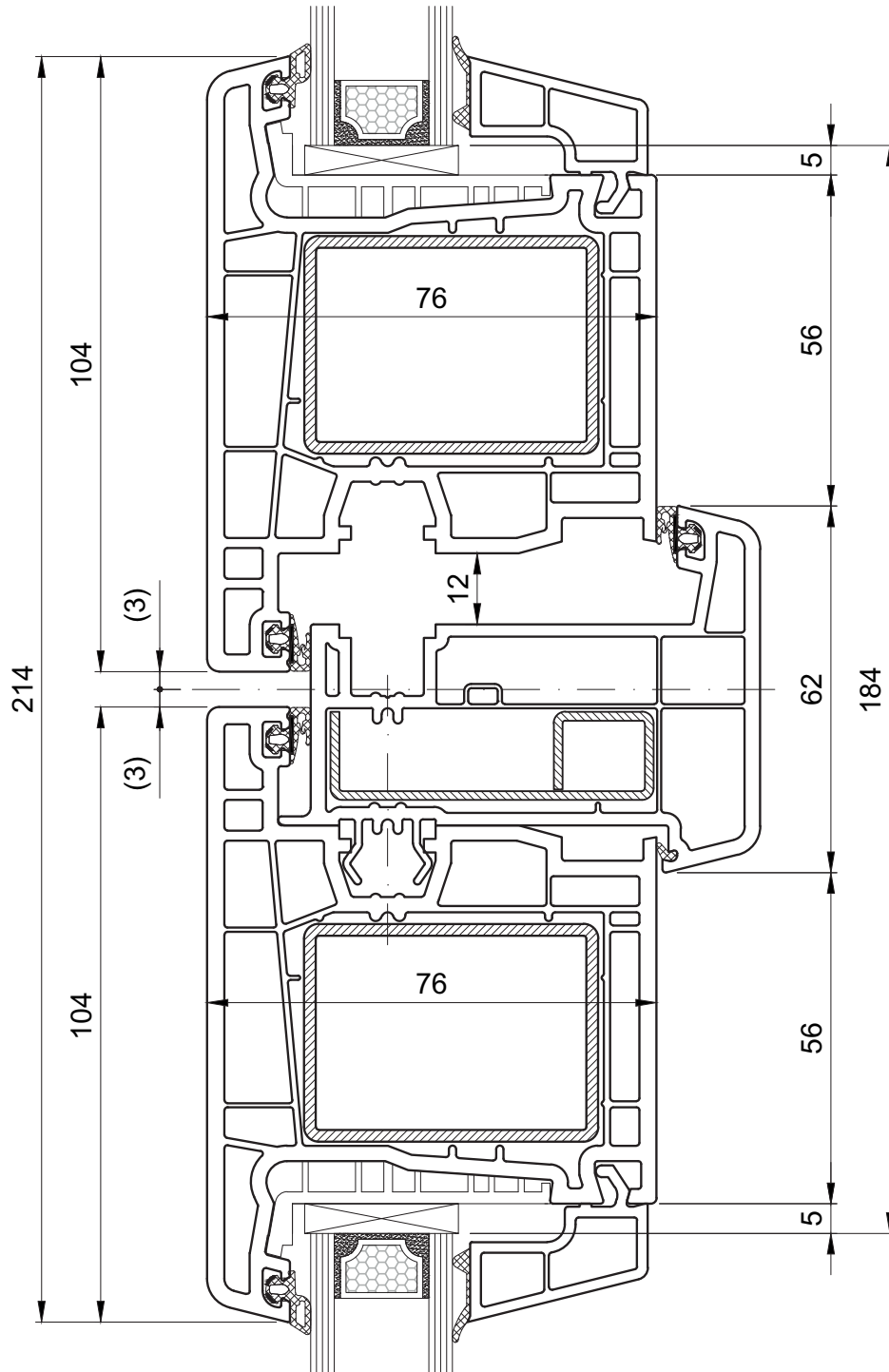
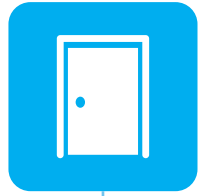

Słupek ruchomy 62 mm z dwoma skrzydłami tarasowymi, otwierane na zewnątrz



Coupe de deux ouvrants de porte de passage avec meneau mobile de 62 mm, ouverture vers l'extérieur



Aansluiting van twee terras vleugels met brede stijl 62 mm, naar buiten opendraaiend



Zwei Terrassenflügel verbunden mit Hilfe eines breiten Stulps mit 62 mm Breite, nach Aussen öffnend



Guinzione di due ante portaverande con montante mobile 62 mm, l'apertura verso esterno





Streamline 76

251 040 - 256 030 - 251 040

**OKO
OKNA**

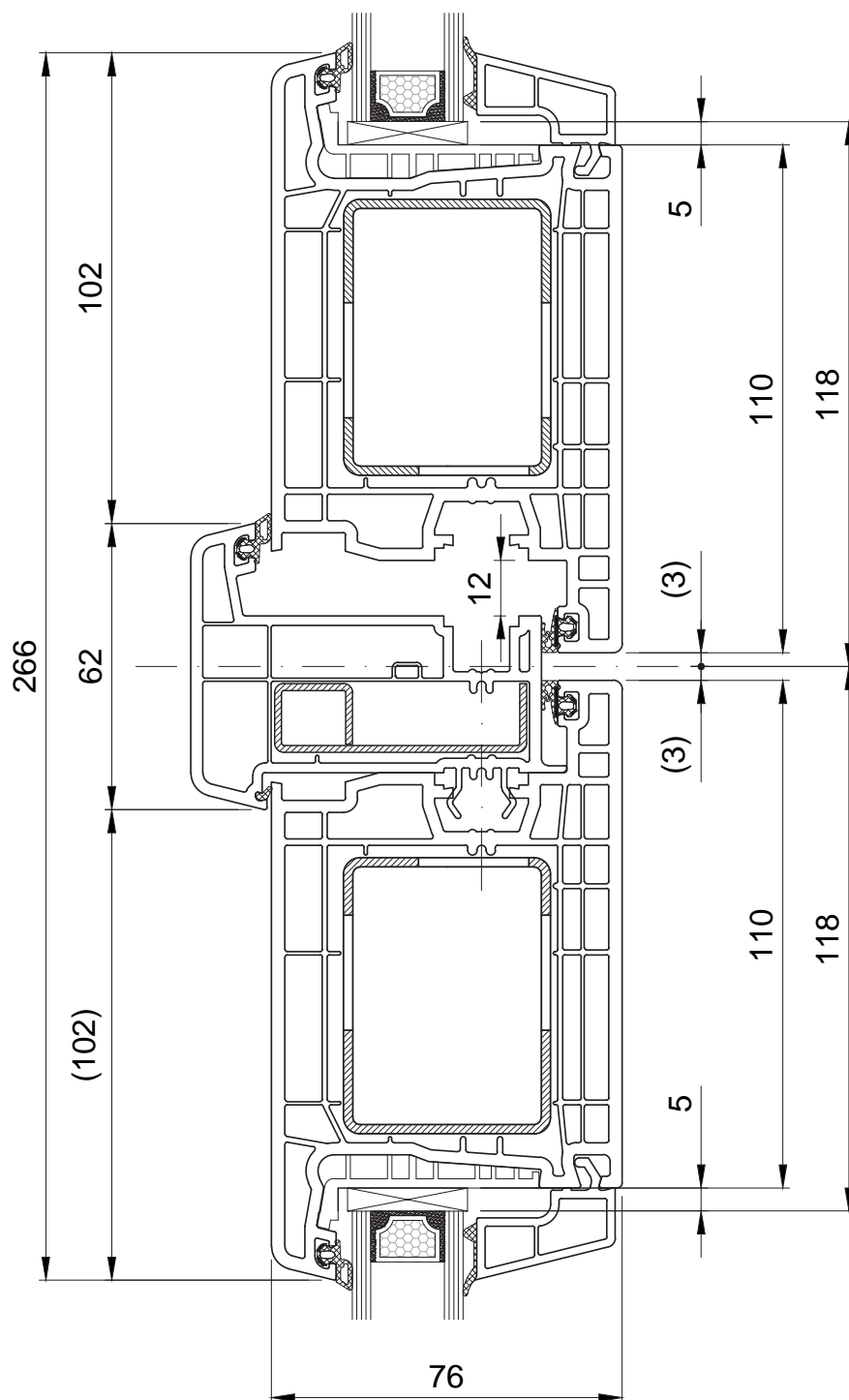

Słupek ruchomy 62 mm z dwoma skrzydłami drzwiowymi, otwierane do wewnątrz

Coupe de deux ouvrants de porte, meneau mobile de 62 mm, ouverture vers l'intérieur

Aansluiting van twee deur vleugels met brede stijl 62 mm, naar binnen opendraaiend

Zwei Türflügel verbunden mit Hilfe eines breiten Stulps mit 62 mm Breite, nach Innen öffnend

Guinzione di due ante della porta montante mobile 62 mm, l'apertura verso interno



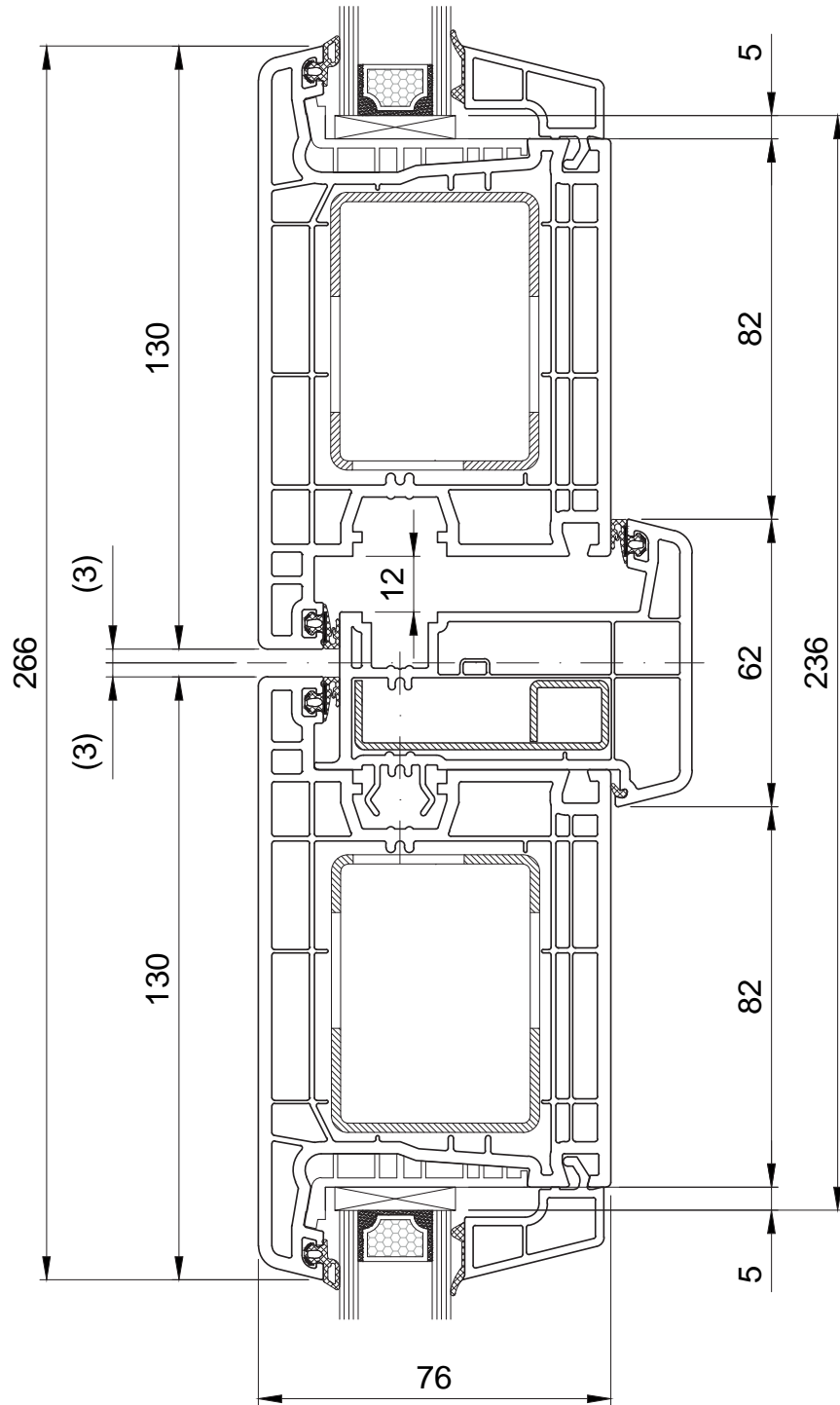
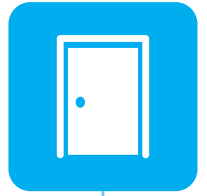

Słupek ruchomy 62 mm z dwoma skrzydłami drzwiowymi, otwierane na zewnątrz



Coupe de deux ouvrants de porte, meneau mobile de 62 mm, ouverture vers l'extérieur



Aansluiting van twee deur vleugels met brede stijl 62 mm, naar buiten opendraaiend



Zwei Türflügel verbunden mit Hilfe eines breiten Stulps mit 62 mm Breite, nach Aussen öffnend



Guinzione di due ante della porta montante mobile 62 mm, l'apertura verso esterno



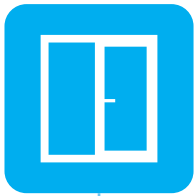

Streamline 76

256 030

**OKO
OKNA**

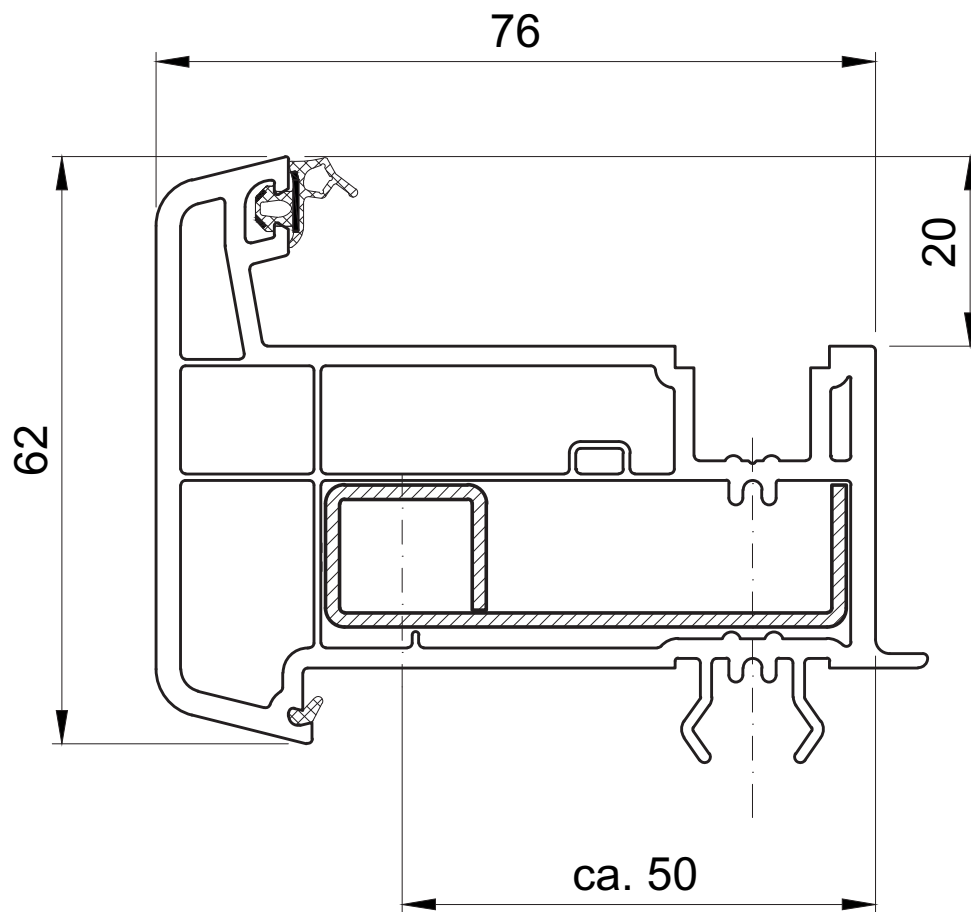

SALAMANDER
WINDOW & DOOR SYSTEMS

Słupek ruchomy 62 mm 

Meneau mobile de 62 mm 

Brede stijl 62 mm stulp 

Breiter Stulp 62 mm 

Montante mobile 62 mm 

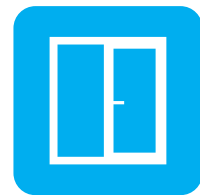

BluEvolution 82 Classic-line



BluEvolution 82 | 6 komór | 3 uszczelki

Stal pokazana na rysunku może nie być stalą stosowaną standardowo.



BluEvolution 82 | 6 chambres | 3 joints

Renfort en acier présenté sur le dessin ci-dessus est en option.



BluEvolution 82 | 6 kamers | 3 afdichtingen

Staal die u op de tekening ziet, is niet standaard.



BluEvolution 82 | 6 Kammern | 3 Dichtungen

Der angewendete Stahlkern kann von dem abgebildeten Kern abweichen.



BluEvolution 82 | 6 camere | 3 guarnizioni

L'acciaio presentato sul disegno può essere un acciaio non standard.



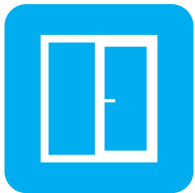

BluEvolution 82 **bE**

HO9020 - HO8520

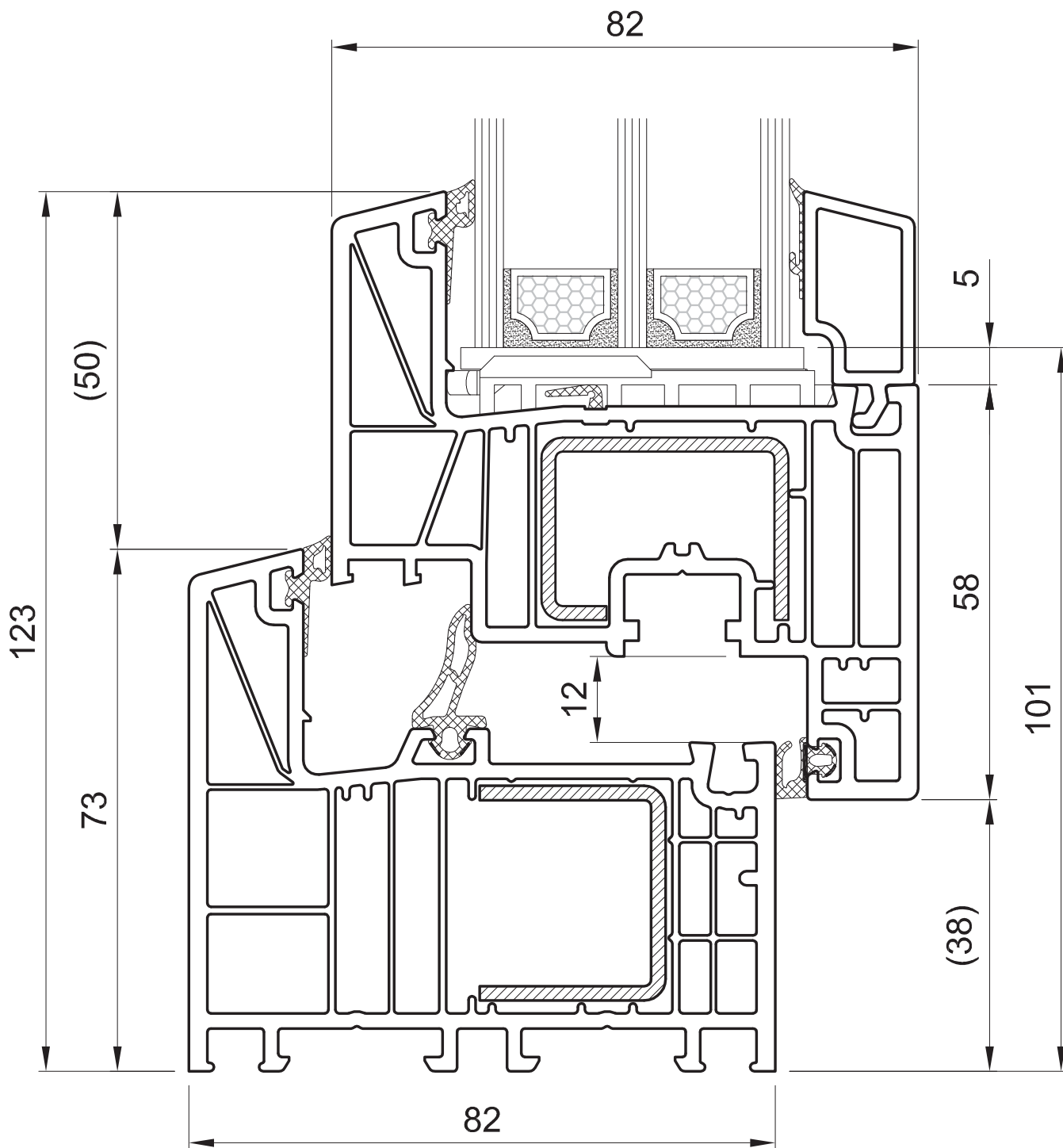

SALAMANDER
WINDOW & DOOR SYSTEMS

- Profil Classic-line 
- Profil de fenêtre Classic-line 
- Raamprofiel Classic-line 
- Flügelprofil Classic-line 
- Profilo finestra Classic-line 

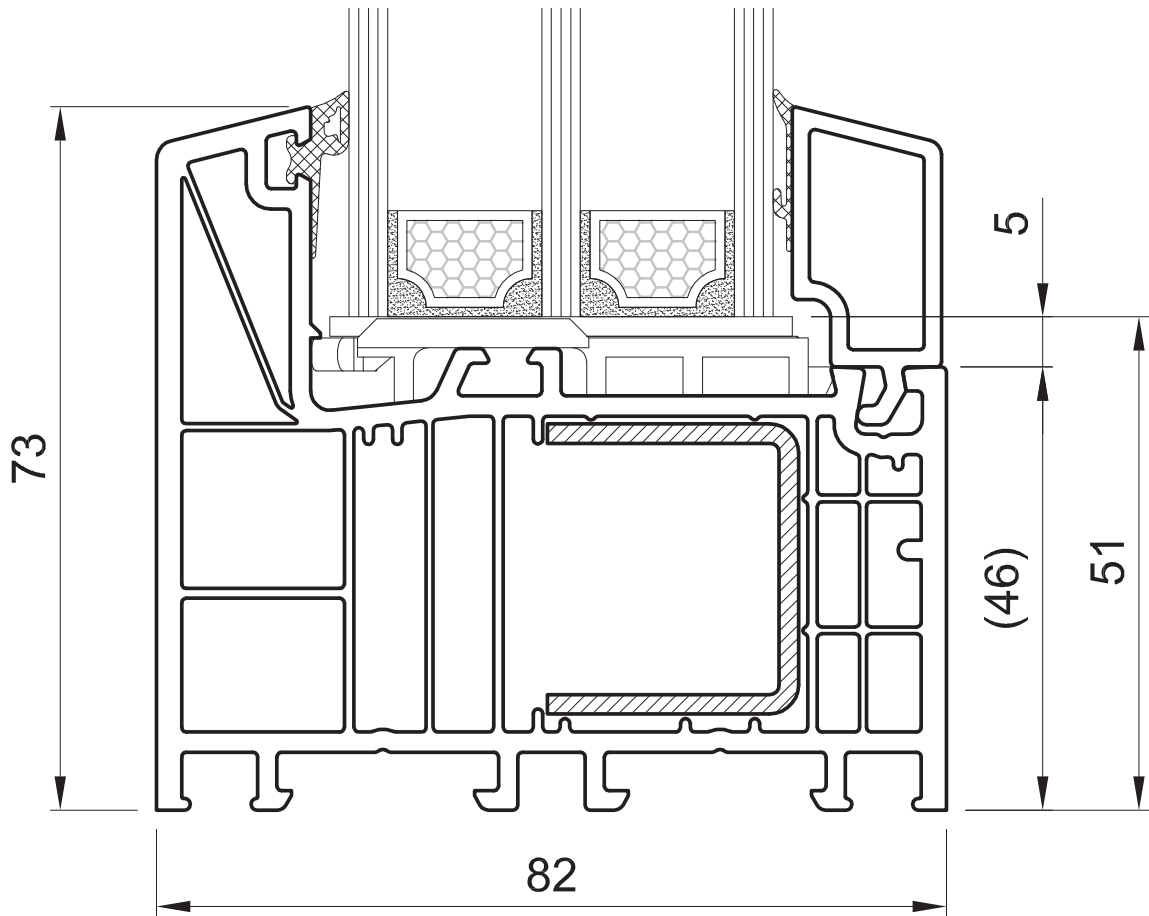

-  Szklenie w ramie
-  Dormant de fenêtre standard
-  Raamkader standard
-  Fensterrahmen standard
-  Telaio finestra standard





BluEvolution 82 **bE**

HO9020 - HO8530

**OKO
OKNA**

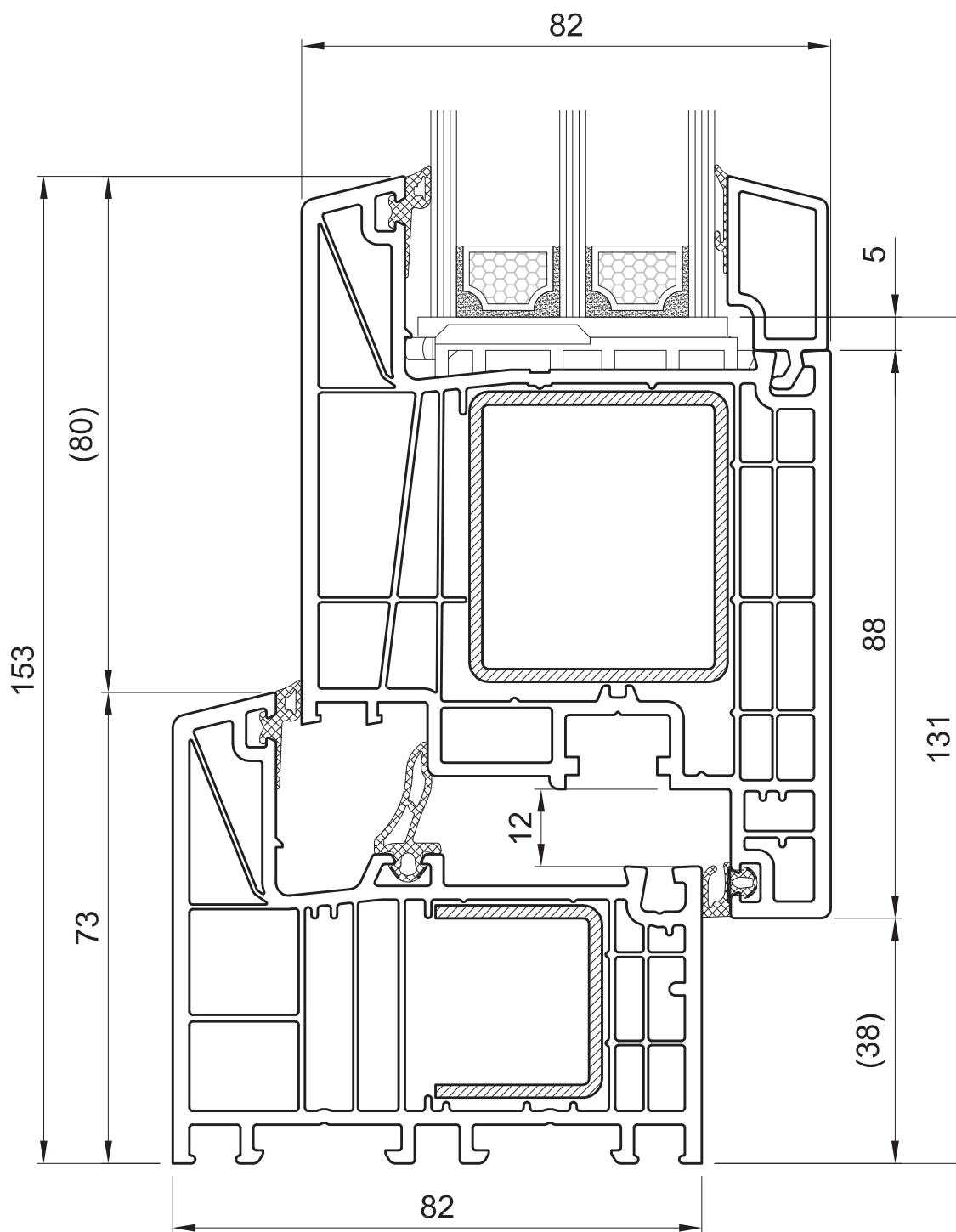

Drzwi tarasowe, otwierane do wewnątrz

Porte de passage, ouverture vers l'intérieur

Terras profiel, naar binnen opendraaiend

Terassentür, nach Innen öffnend

Portaveranda, l'apertura verso interno



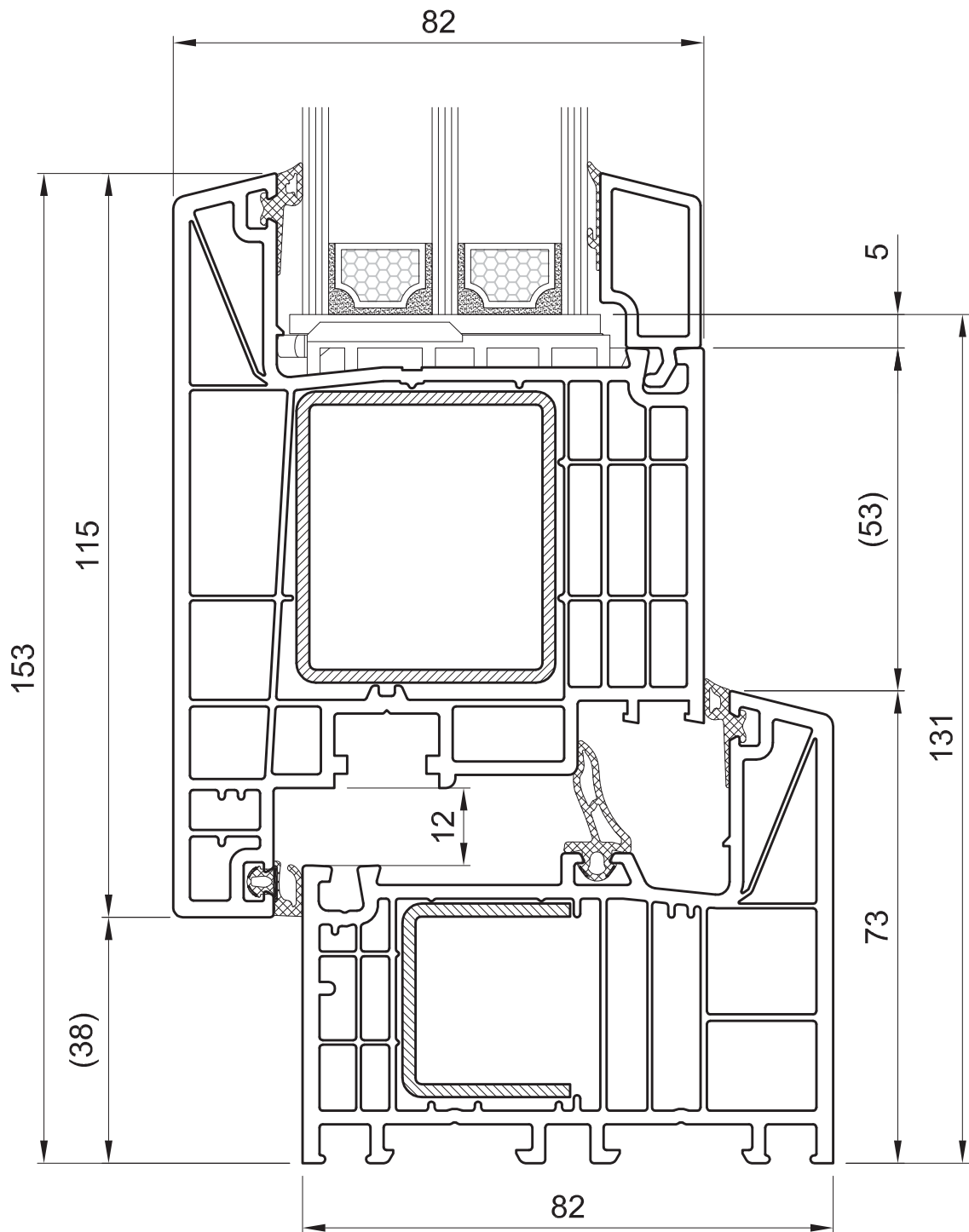
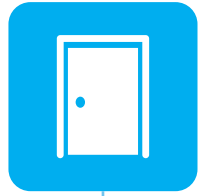

Drzwi tarasowe, otwierane na zewnątrz



Porte de passage, ouverture vers l'extérieur



Terras profiel, naar buiten opendraaiend



Terassentür, nach Aussen öffnend



Portaveranda, l'apertura verso esterno





BluEvolution 82 **bE**

HO9020 - HP8550

**OKO
OKNA**

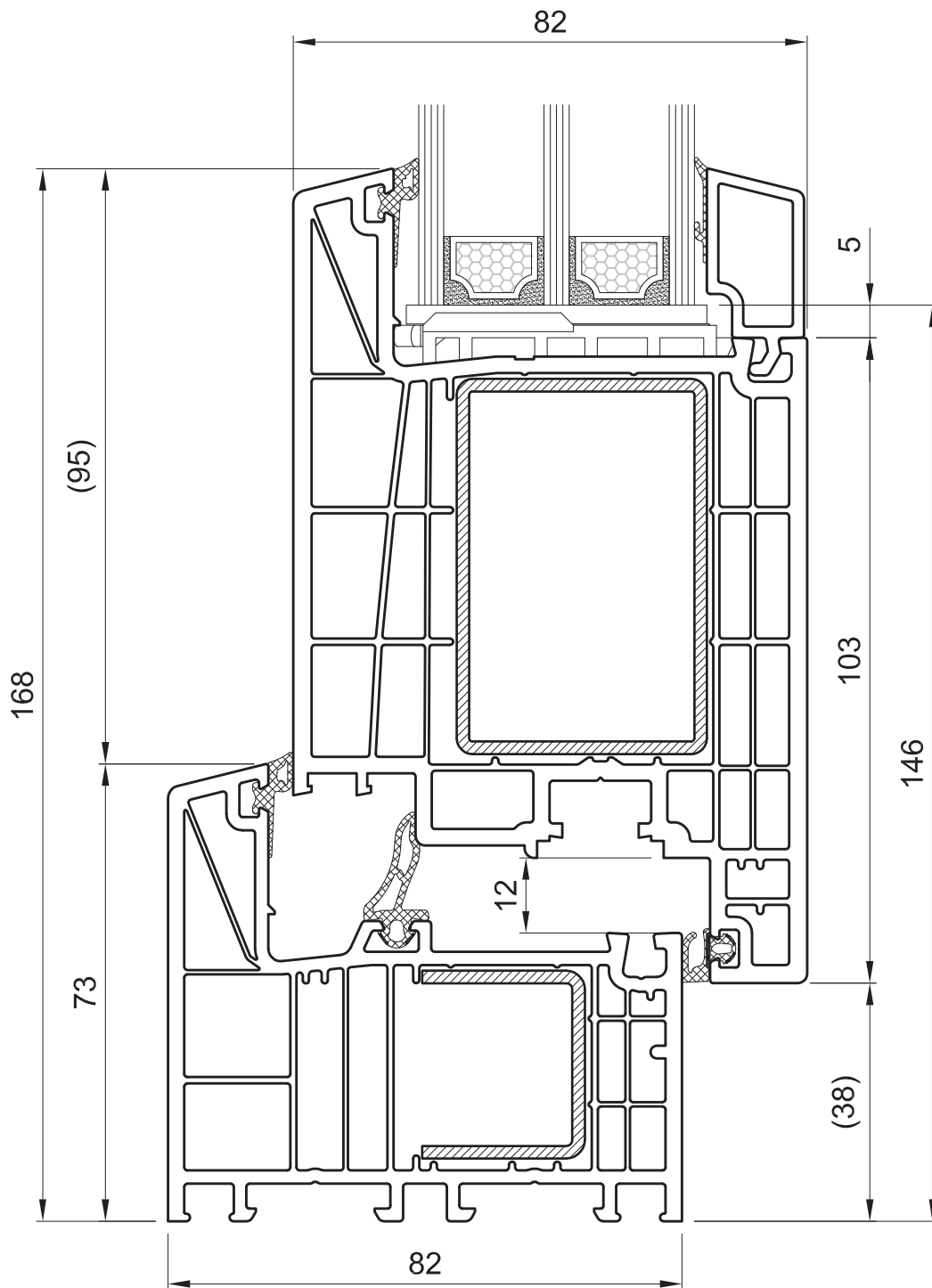

Drzwi wejściowe, otwierane do wewnątrz

Porte d'entrée, ouverture vers l'intérieur

Deur, naar binnen opendraaiend

Eingangstür, nach Innen öffnend

Porta d'ingresso, l'apertura verso interno



SALAMANDER
WINDOW & DOOR SYSTEMS

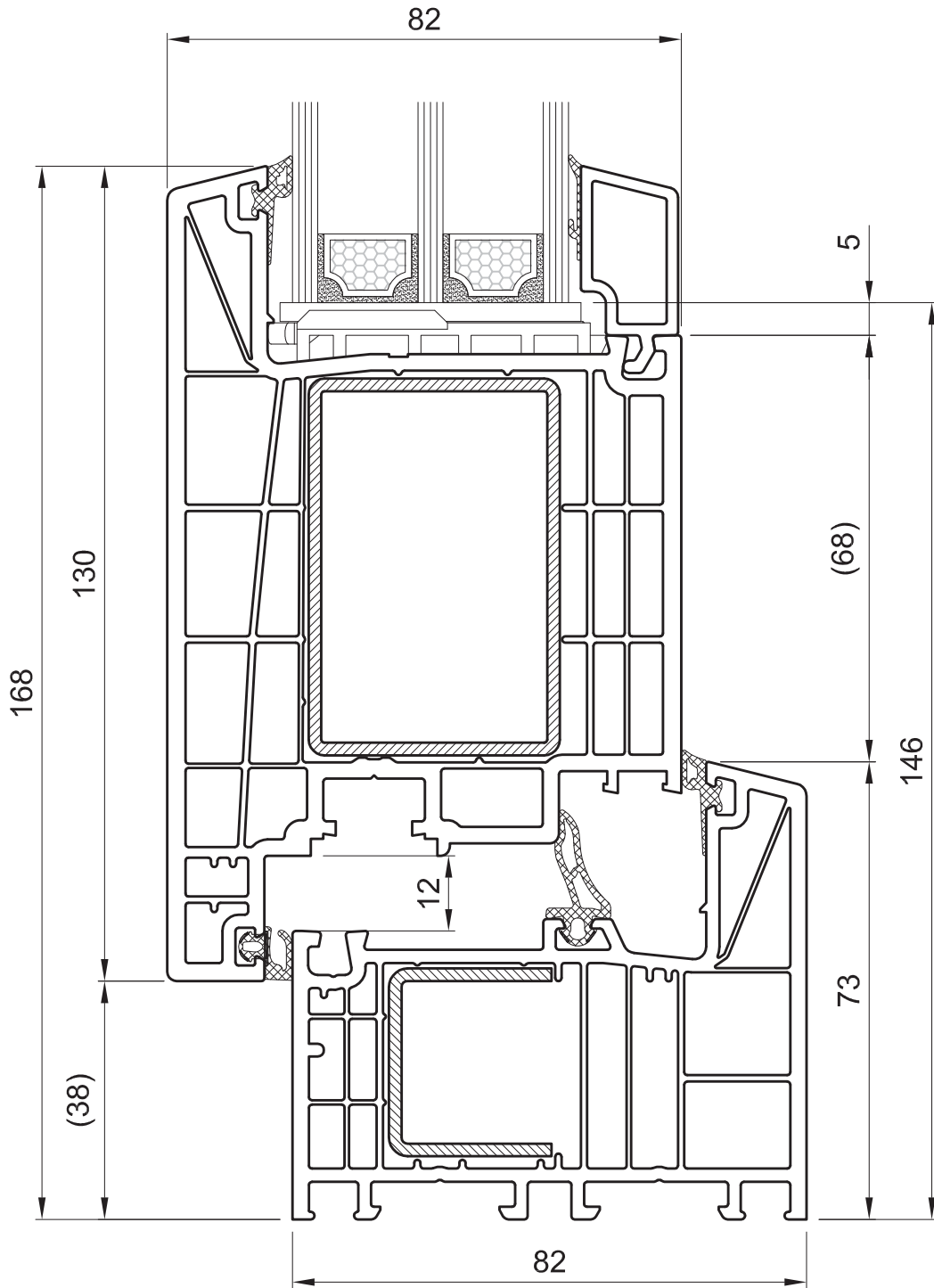
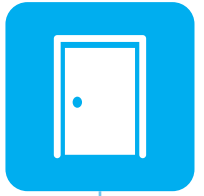

Drzwi wejściowe, otwierane na zewnątrz



Porte d'entrée, ouverture vers l'extérieur



Deur, naar buiten opendraaiend



Eingangstür, nach Aussen öffnend



Porta d'ingresso, l'apertura verso esterno



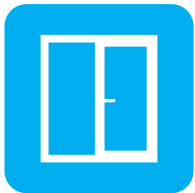

BluEvolution 82 **bE**

HO9030

**OKO
OKNA**

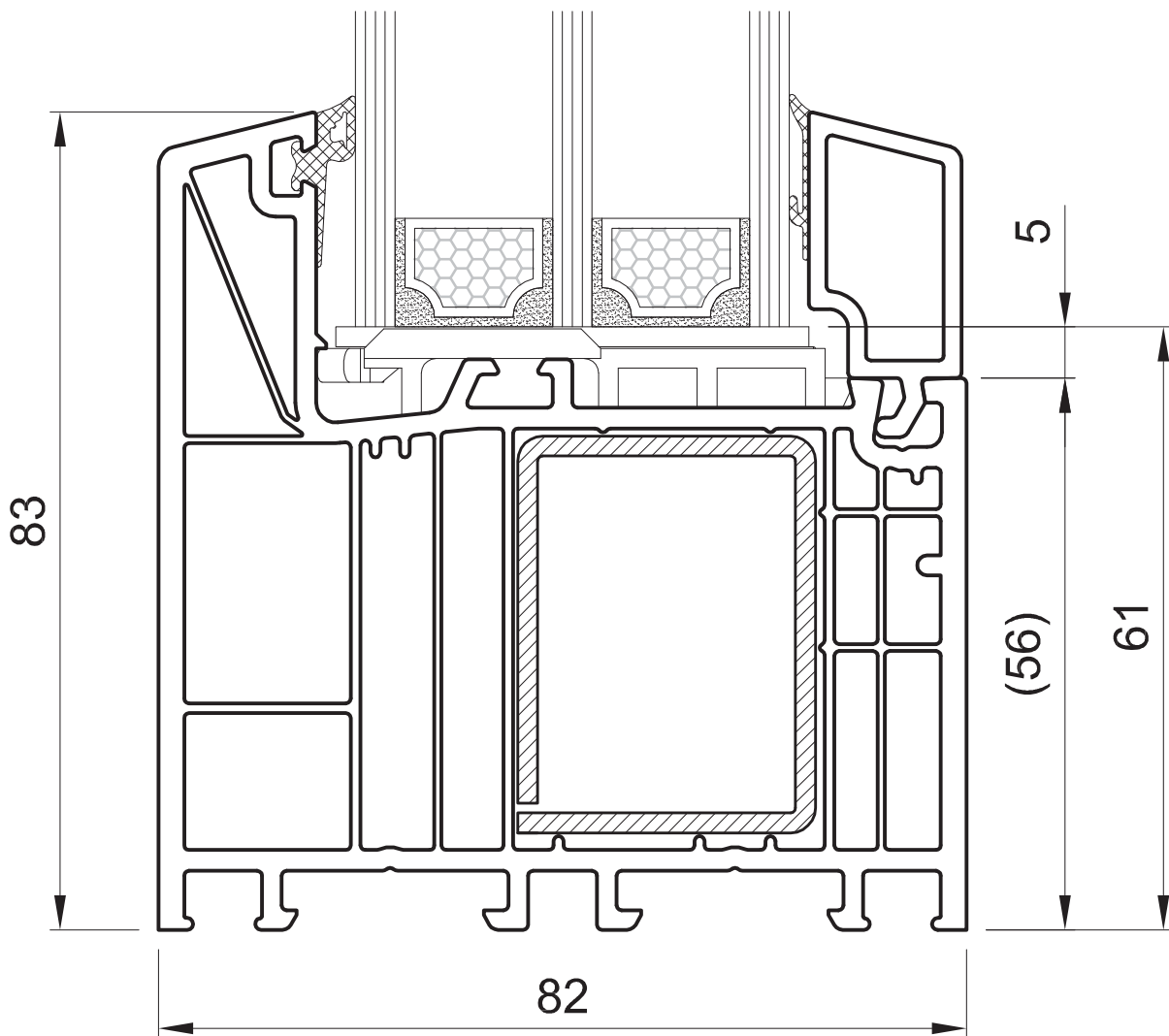

Szklenie w ramie drzwiowej 

Fixe - dormant 





Vast raam - kader 

Festverglasung - Rahmen 

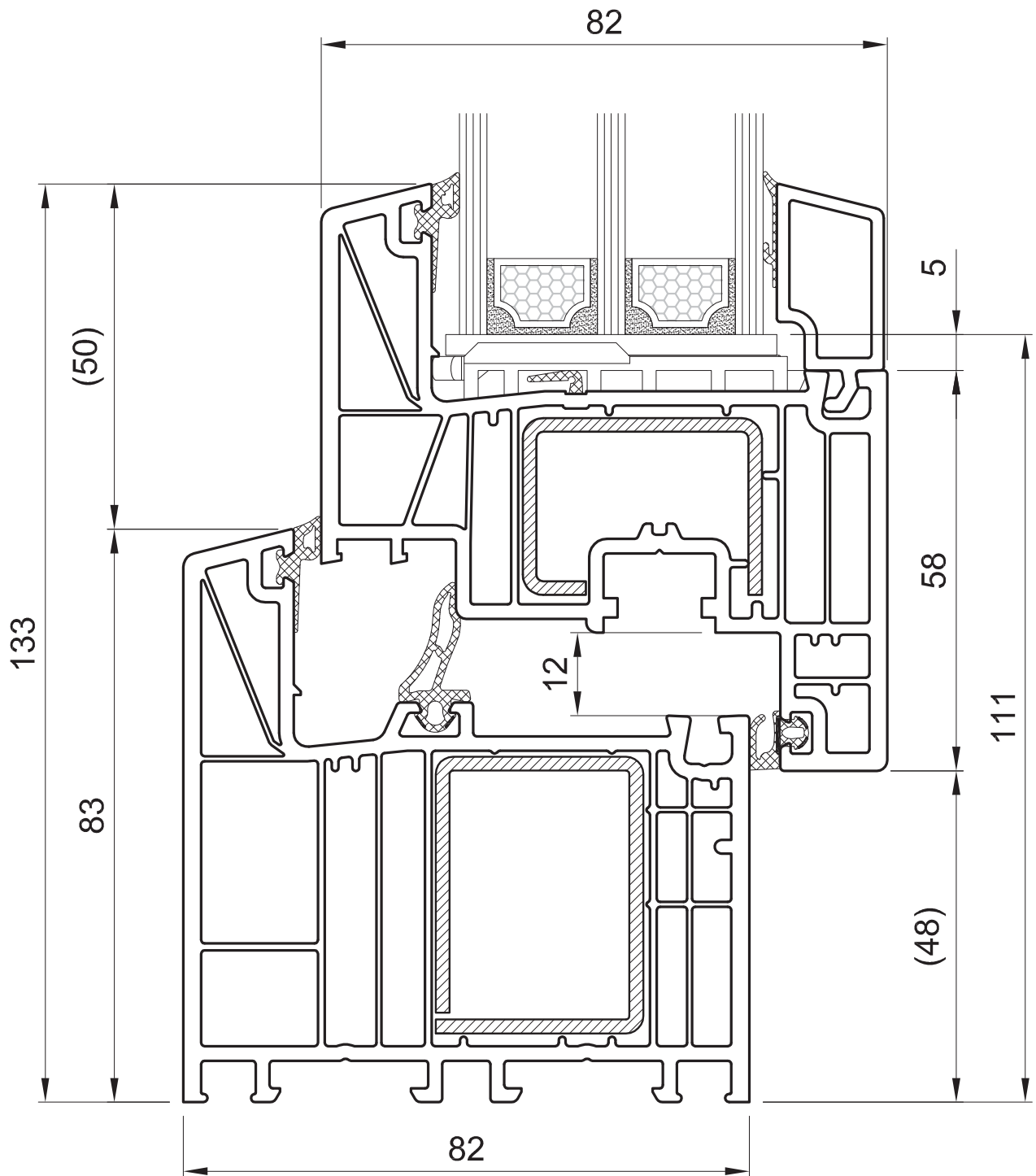
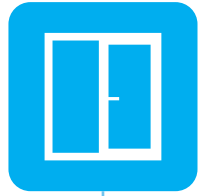
Serramento fisso - telaio 





-  Skrzydło okienne + rama drzwiowa
-  Overant de fenêtre avec dormant de porte
-  Raamvleugel + deurkader
-  Fensterflügel + Türrahmen
-  Anta finestra + telaio della porta





BluEvolution 82 **bE**

HO9030 - HO8530

**OKO
OKNA**

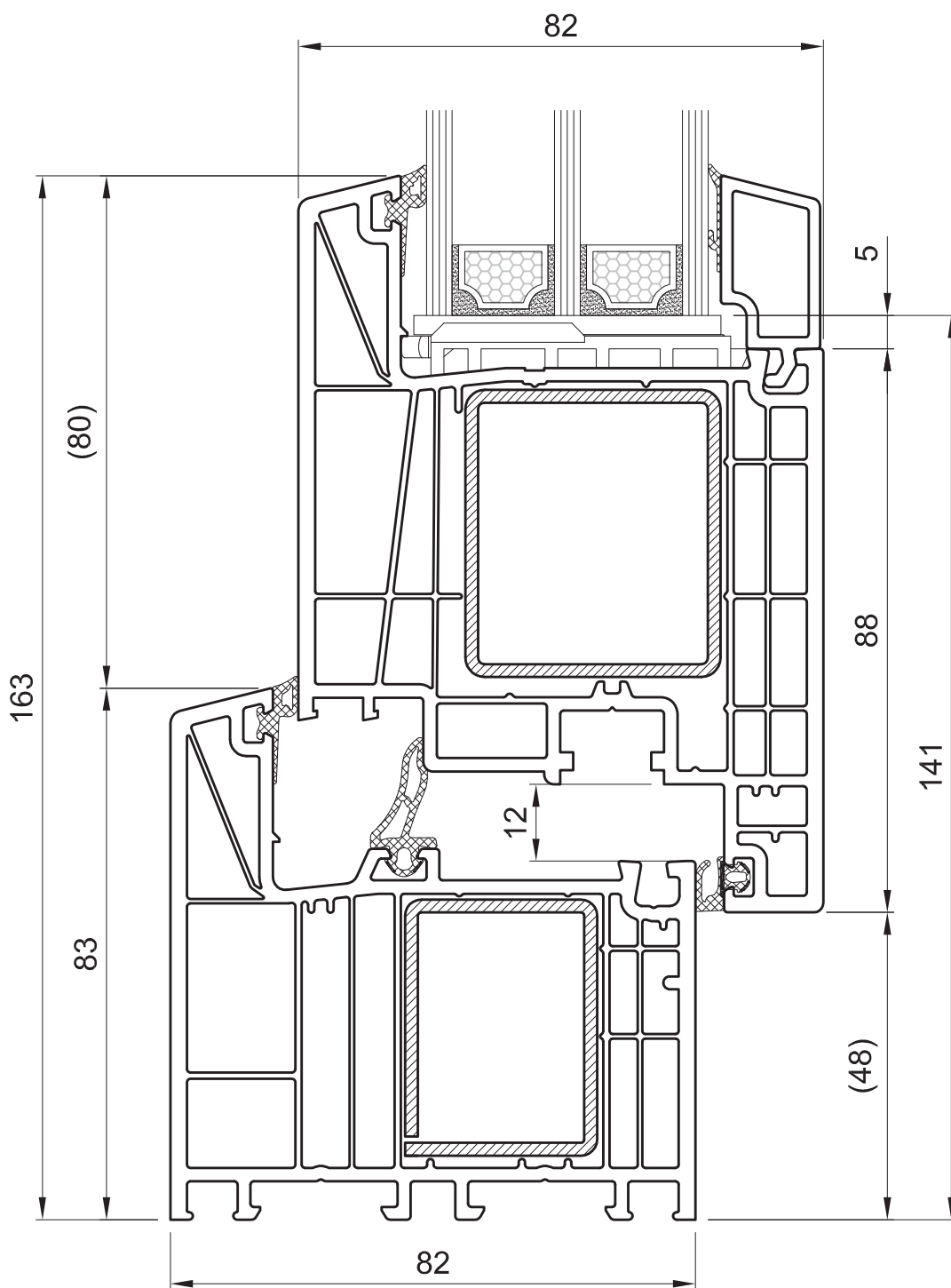

SALAMANDER
WINDOW & DOOR SYSTEMS

Skrzydło tarasowe, otwierane do wewnątrz

Porte de passage, ouverture vers l'intérieur

Terras profiel, naar binnen opendraaiend

Terrassentür, nach Innen öffnend

Portaveranda, l'apertura verso interno



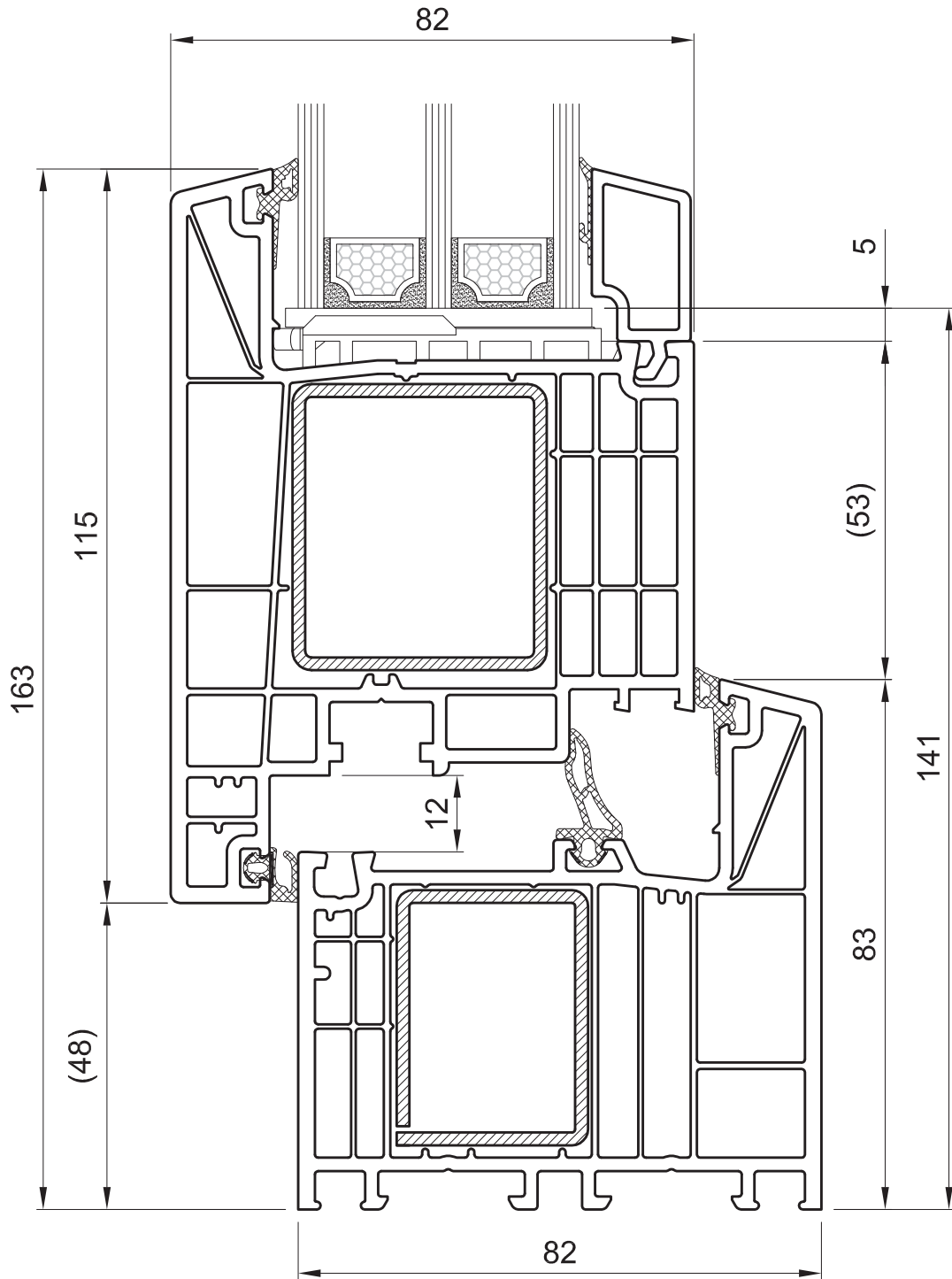

Skrzydło tarasowe, otwierane na zewnątrz



Porte de passage, ouverture vers l'extérieur



Terras profiel, naar buiten opendraaiend



Terrassentür, nach Aussen öffnend



Portaveranda, l'apertura verso esterno





BluEvolution 82 **bE**

HO9030 - HP8550

**OKO
OKNA**

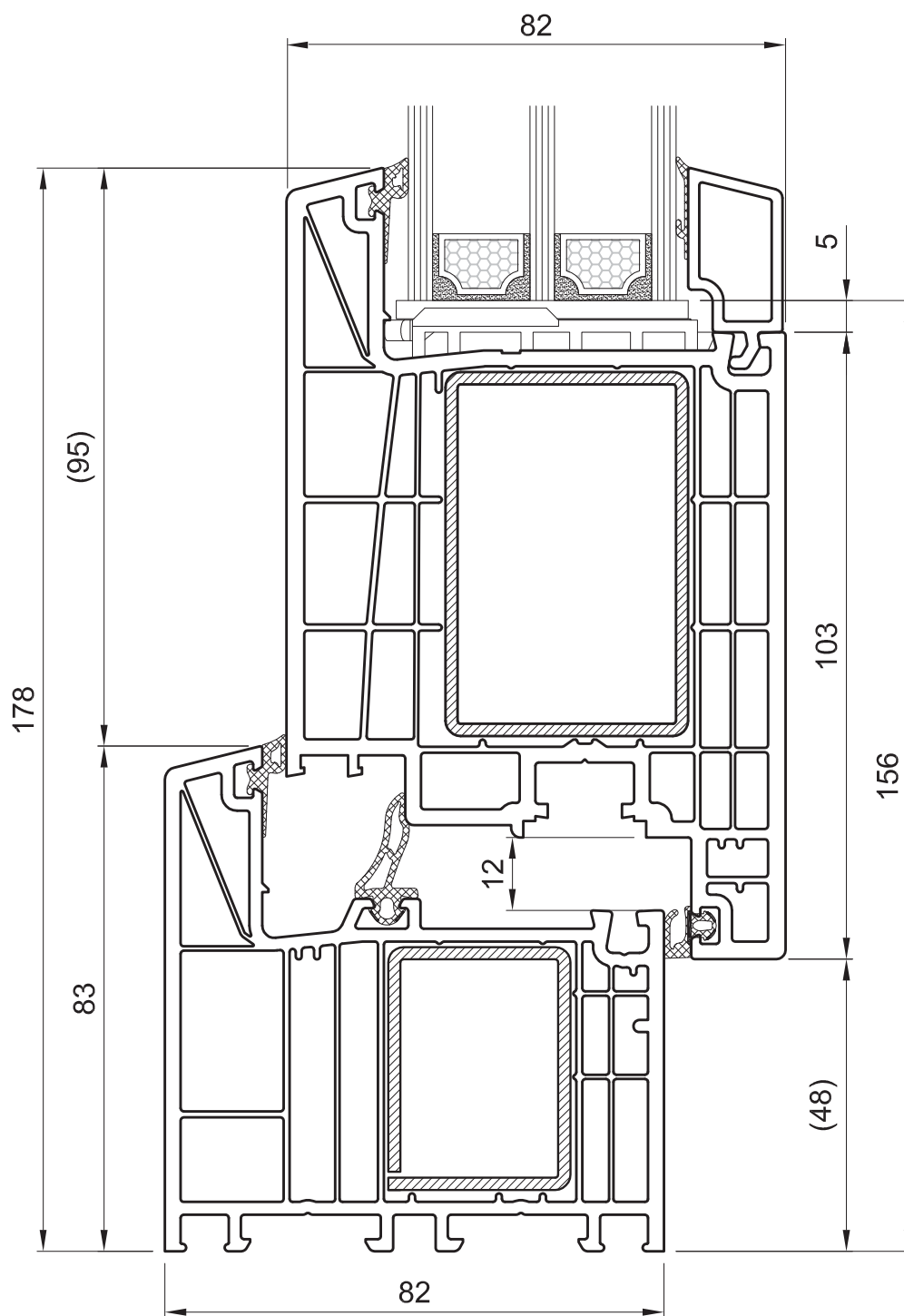

Drzwi wejściowe, otwierane do wewnątrz



Porte d'entrée, ouverture vers l'intérieur



Deur, naar binnen opendraaiend



Eingangstür, nach Innen öffnend



Porta, l'apertura verso interno



SALAMANDER
WINDOW & DOOR SYSTEMS

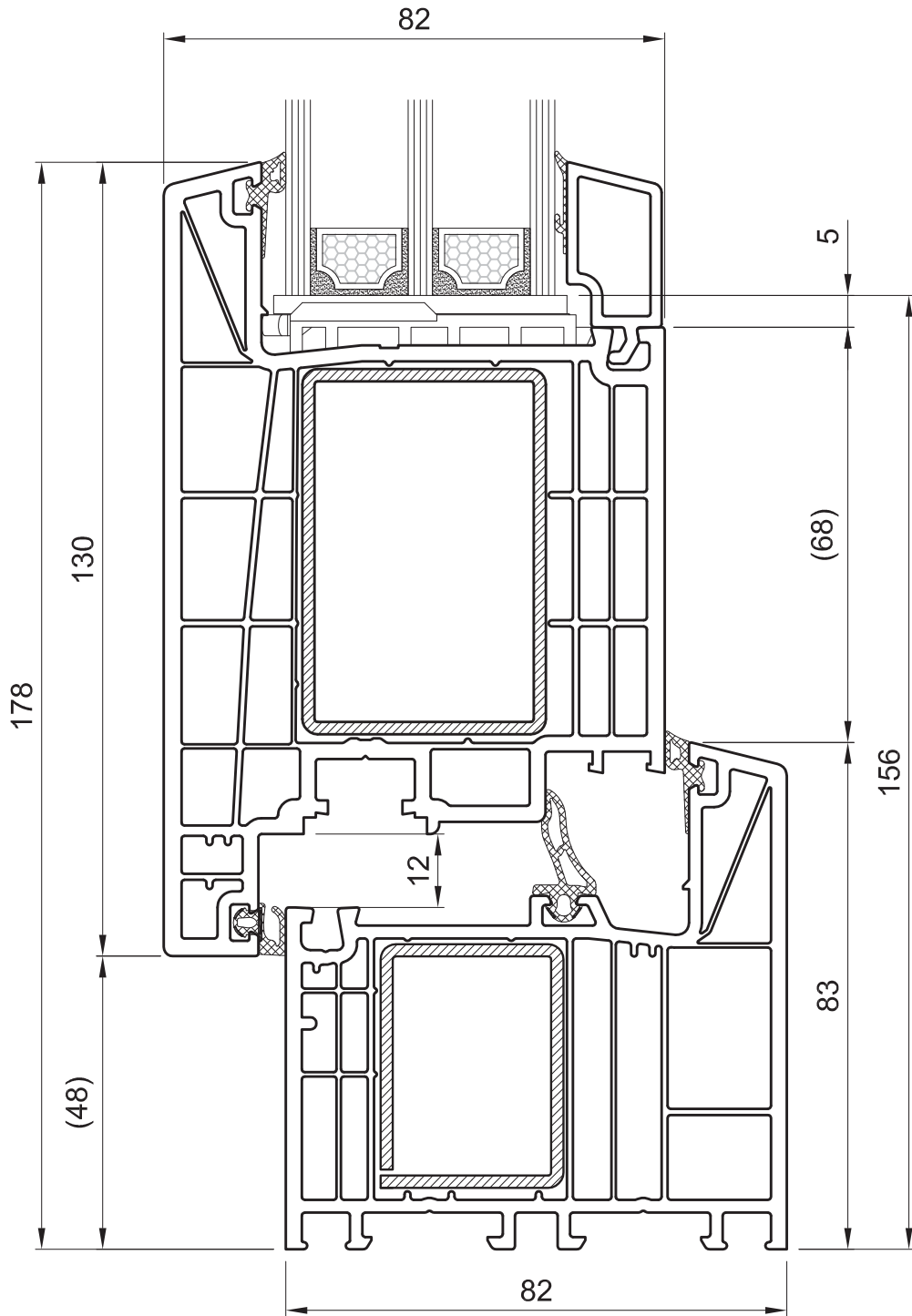

Drzwi wejściowe, otwierane na zewnątrz



Porte d'entrée, ouverture vers l'extérieur



Deur, naar buiten opendraaiend



Eingangstür, nach Aussen öffnend



Porta, l'apertura verso esterno



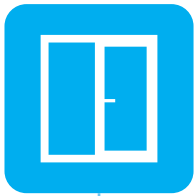

BluEvolution 82 **bE**

HO9110 - HO8520

**OKO
OKNA**

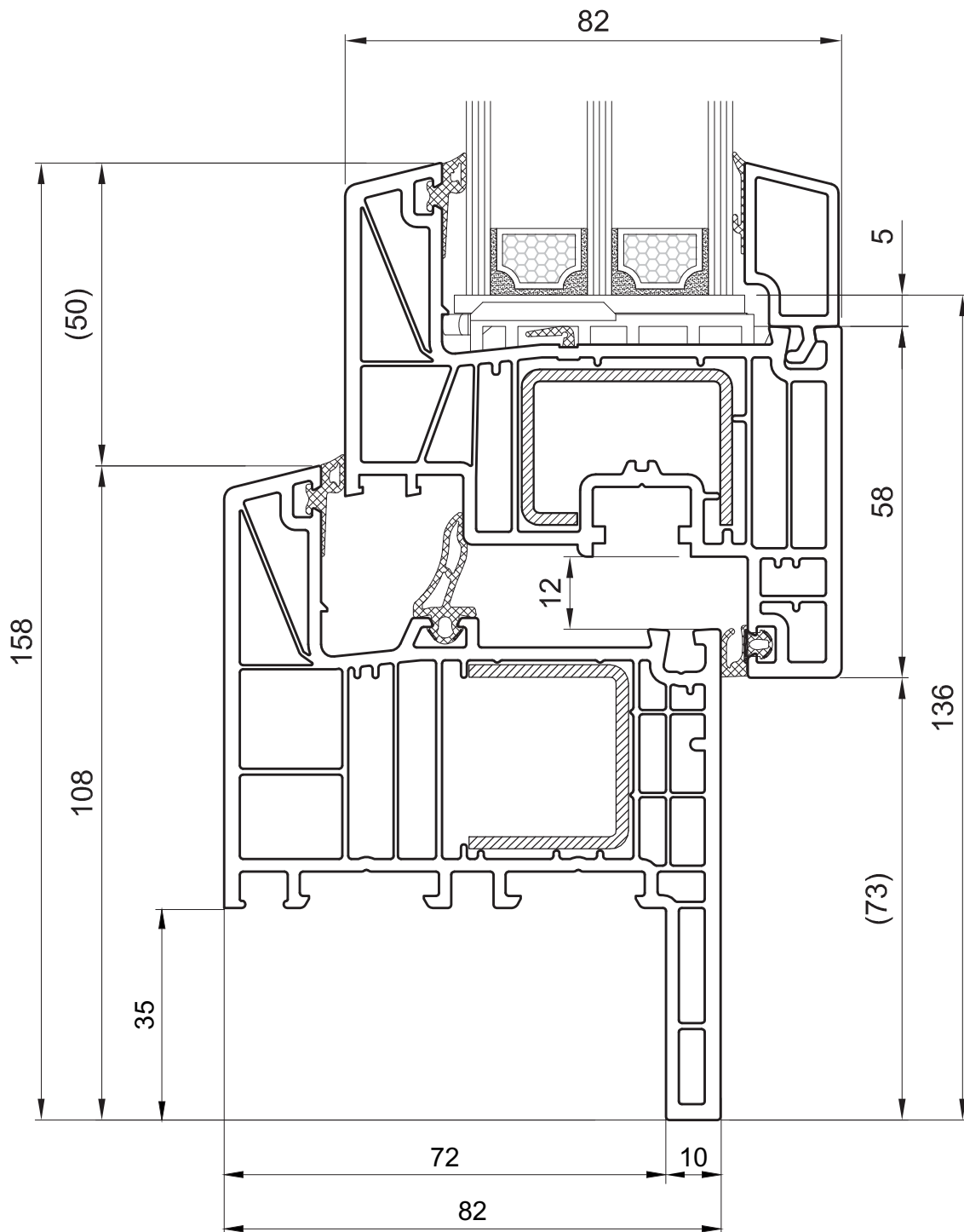

RENOWACJA - Płetwa 35 mm ze skrzydełm Classic-line



RENOVATION - Aile de 35 mm avec ouvrant Classic-line



RENOVATIE - Lip 35 mm + vleugel Classic-line



RENOVIERUNG - Flosse 35 mm mit Flügel Classic-line



RINNOVAZIONE - Aletta da 35 mm con anta Classic-line



SALAMANDER
WINDOW & DOOR SYSTEMS

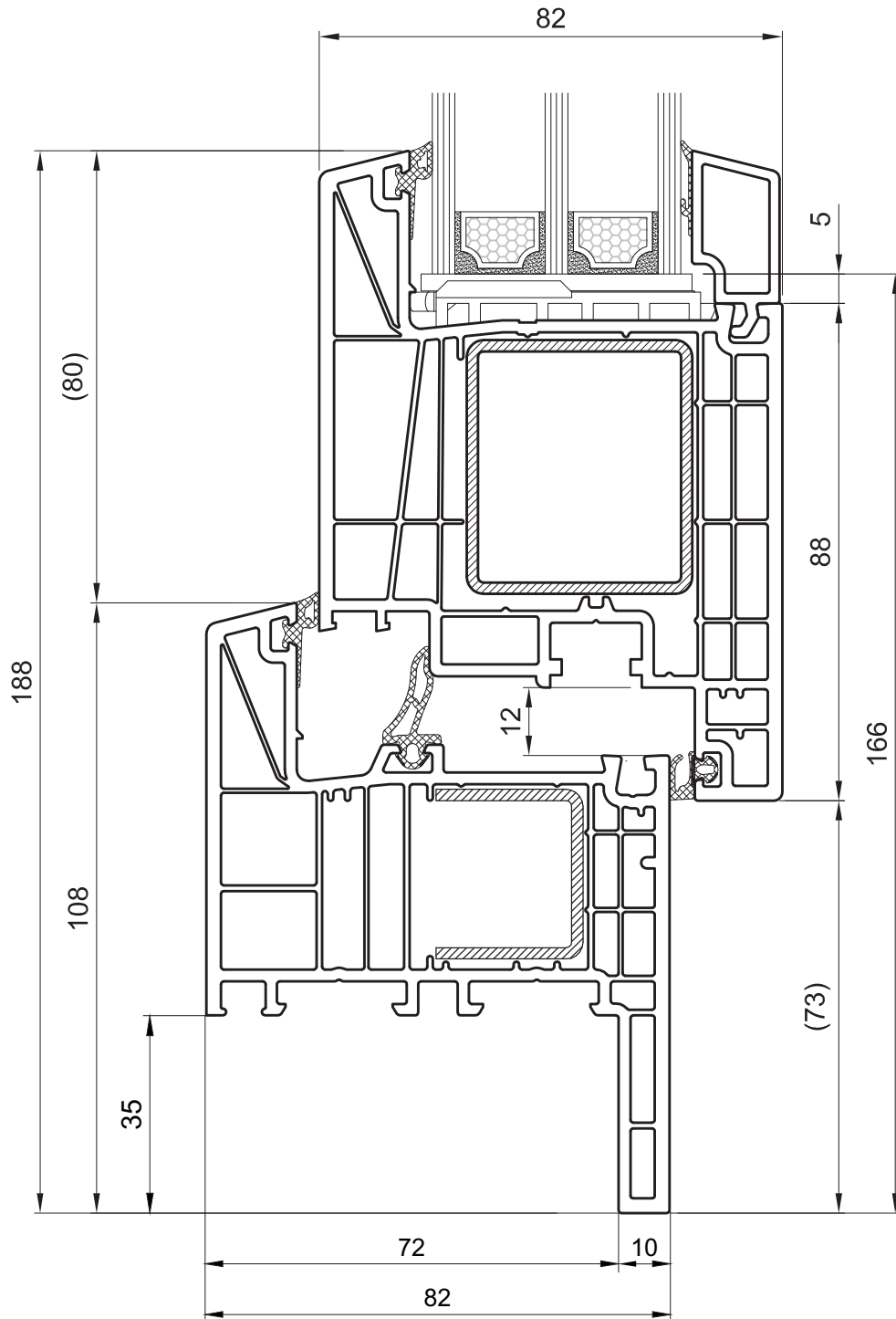

RENOWACJA - Płetwa 35 mm ze skrzydełm tarasowym



RENOVATION - Aile de 35 mm avec porte de passage



RENOVATIE - Lip 35 mm + Terras profiel



RENOVIERUNG - Flosse 35 mm mit Terrassentür



RINNOVAZIONE - Aletta da 35 mm con portaveranda



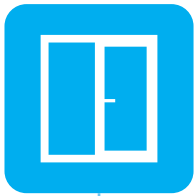

BluEvolution 82 **bE**

HO9110 - HP8550

**OKO
OKNA**

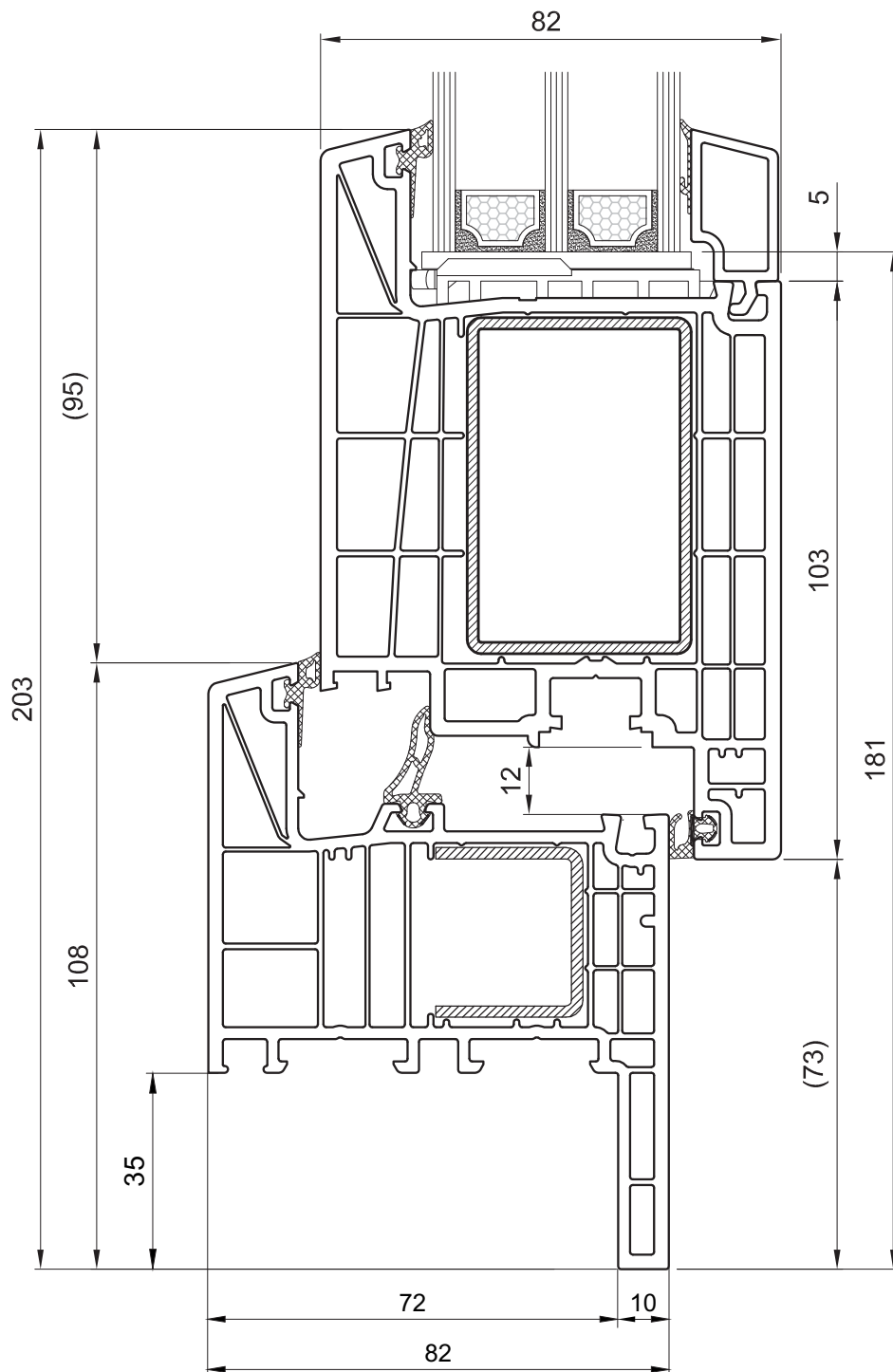

RENOWACJA - Płetwa 35 mm ze skrzydełm drzwiowym, otwierane do wewnątrz

RENOVATION - Aile de 35 mm avec porte d'entrée, ouverture vers l'intérieur

RENOVATIE - Lip 35 mm + deur, naar binnen opendraaiend

RENOVIERUNG - Flosse 35 mm mit Eingangstür, nach Innen öffnend

RINNOVAZIONE - Aletta da 35 mm con porta d'ingresso, l'apertura verso interno



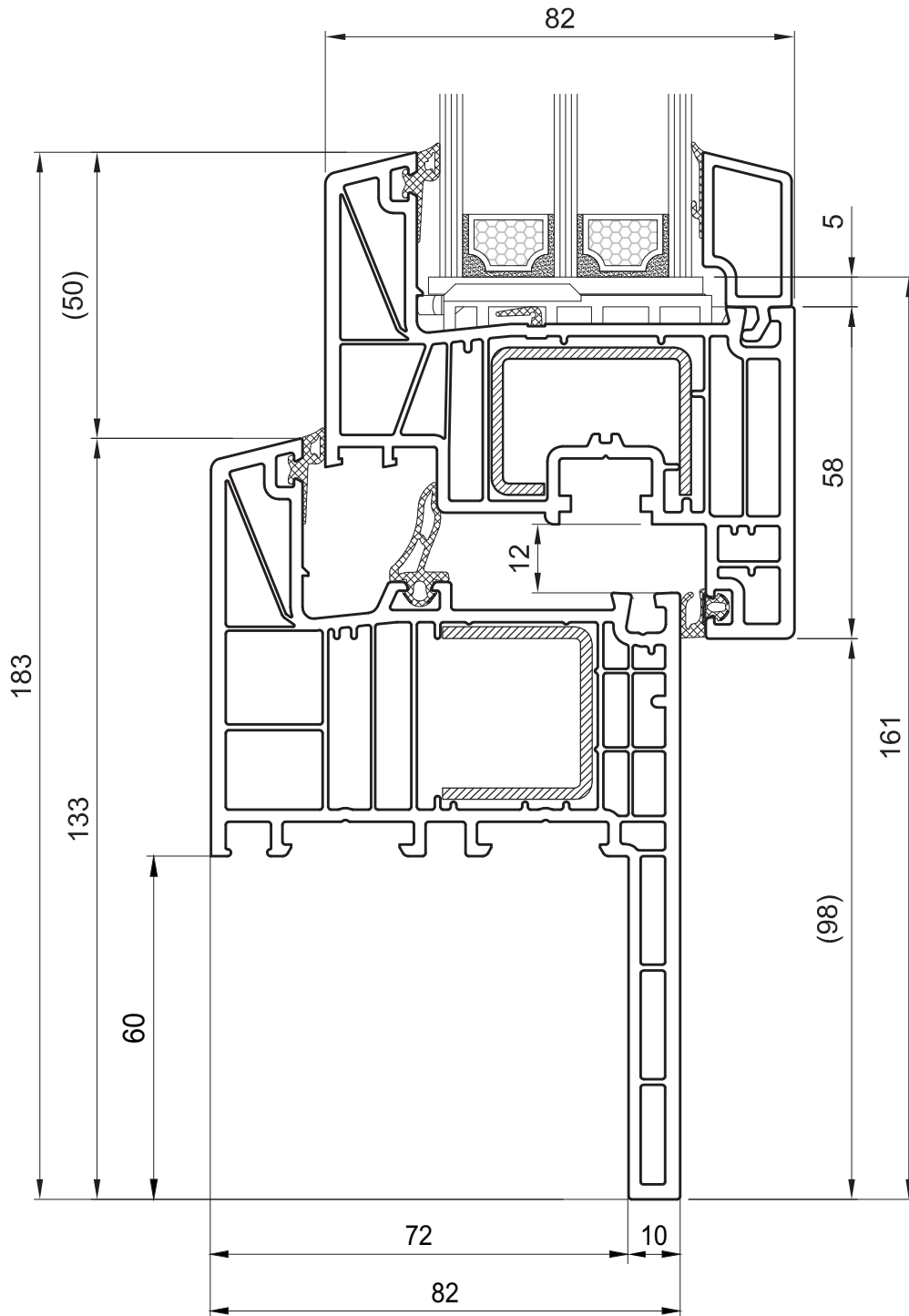
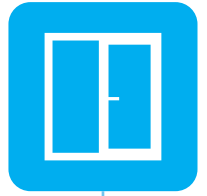

RENOWACJA - Płetwa 60 mm ze skrzydłem Classic-line



RENOVATION - Aile de 60 mm avec ouvrant Classic-line



RENOVATIE - Lip 60 mm + vleugel Classic-line



RENOVIERUNG - Flosse 60 mm mit Flügel Classic-line



RINNOVAZIONE - Aletta da 60 mm con anta Classic-line



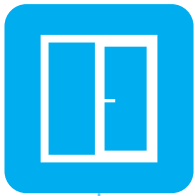

BluEvolution 82 **bE**

HO9100 - HO8530

**OKO
OKNA**

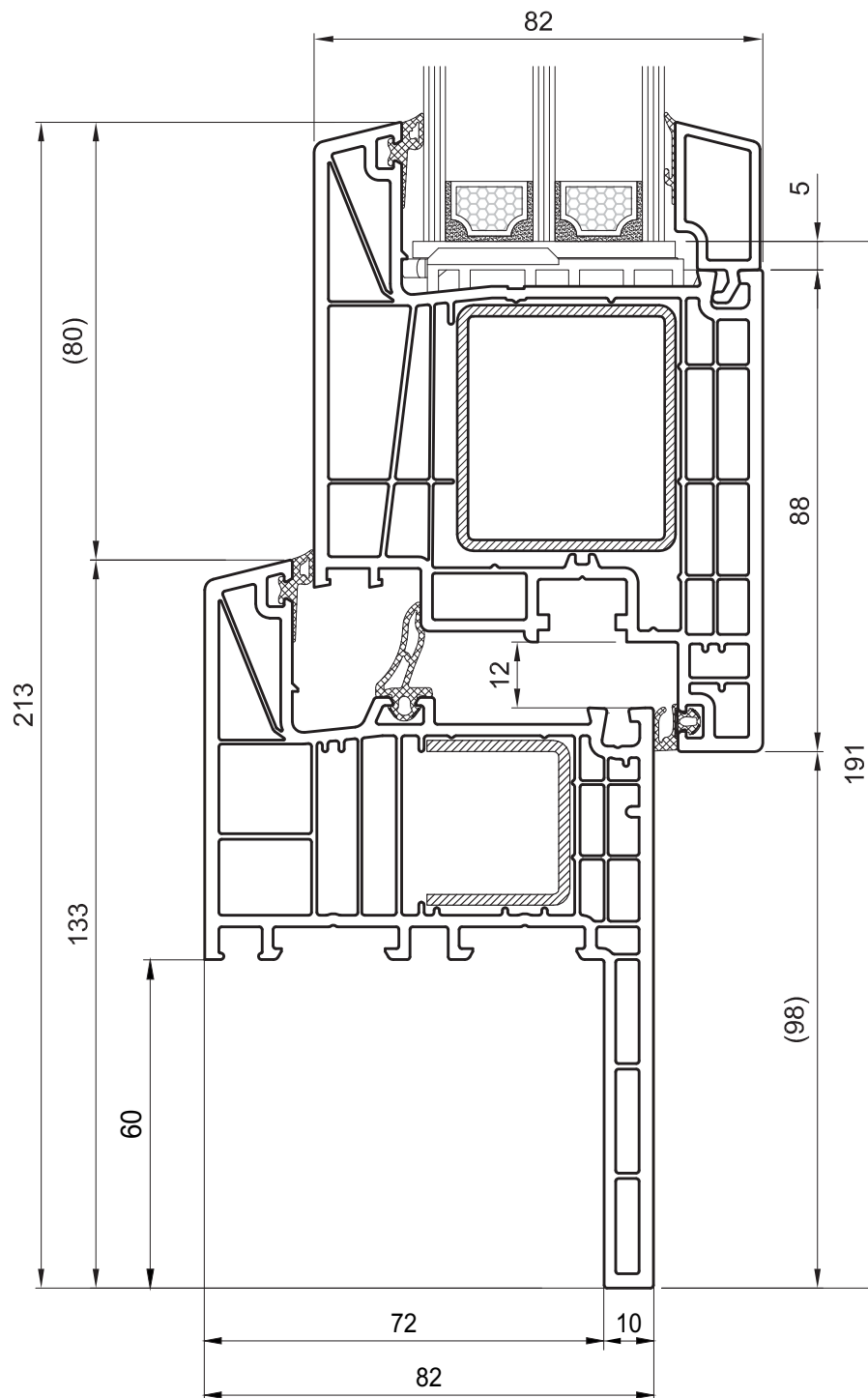

RENOWACJA - Płetwa 60 mm ze skrzydłem tarasowym

RENOVATION - Aile de 60 mm avec porte de passage

RENOVATIE - Lip 60 mm + terras profiel

RENOVIERUNG - Flosse 60 mm mit Terrassentür

RINNOVAZIONE - Aletta da 60 mm con portaveranda



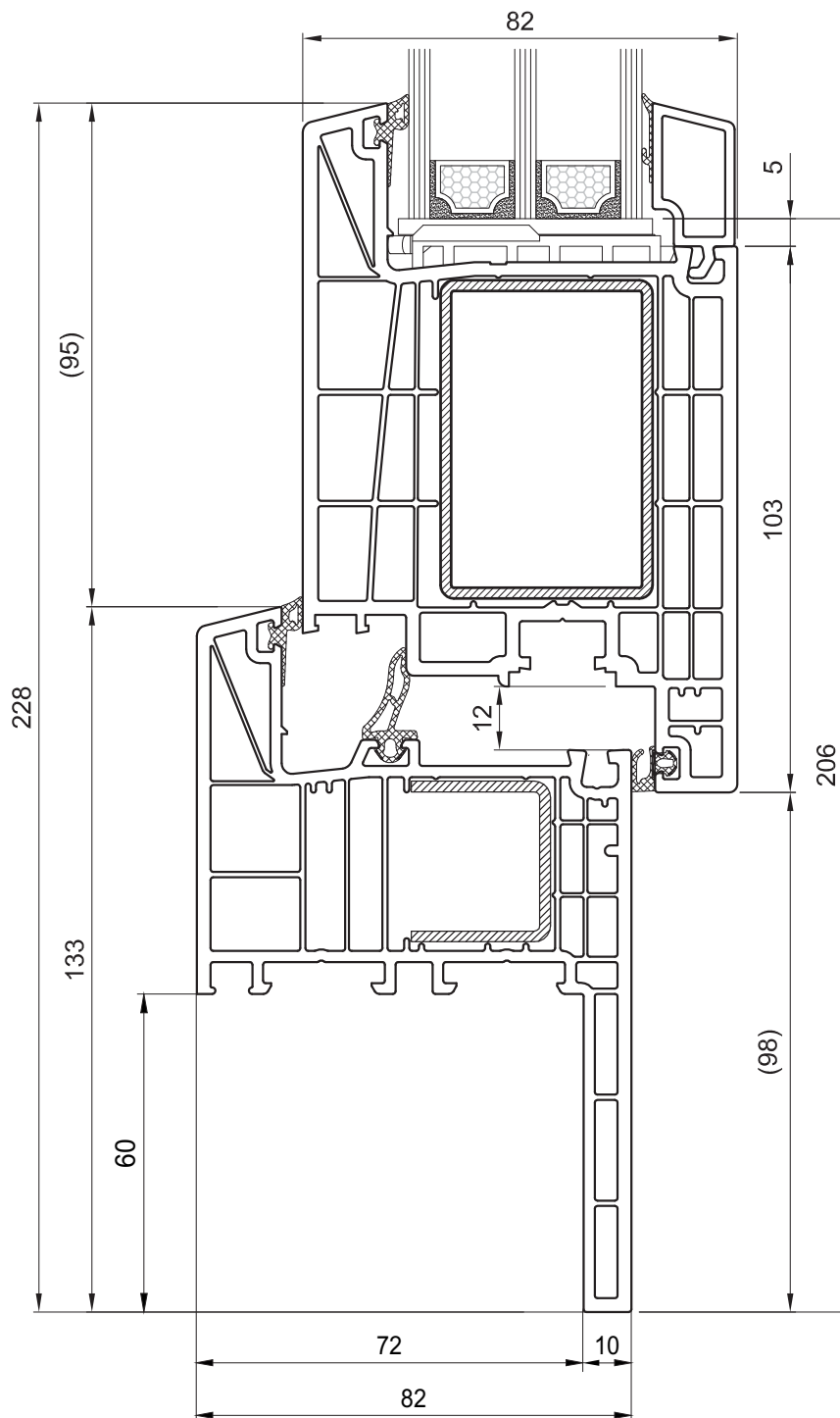

RENOWACJA - Płetwa 60 mm ze skrzydełm drzwiowym, otwierane do wewnątrz



RENOVATION - Aile de 60 mm avec porte d'entrée, ouverture vers l'intérieur



RENOVATIE - Lip 60 mm + deur, naar binnen opendraaiend



RENOVIERUNG - Flosse 60 mm mit Eingangstür, nach Innen öffnend



RINNOVAZIONE - Aletta da 60 mm con porta d'ingresso, l'apertura verso interno



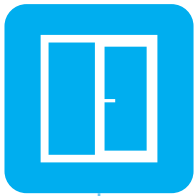

BluEvolution 82 **bE**

HO9320 - HO8520

**OKO
OKNA**

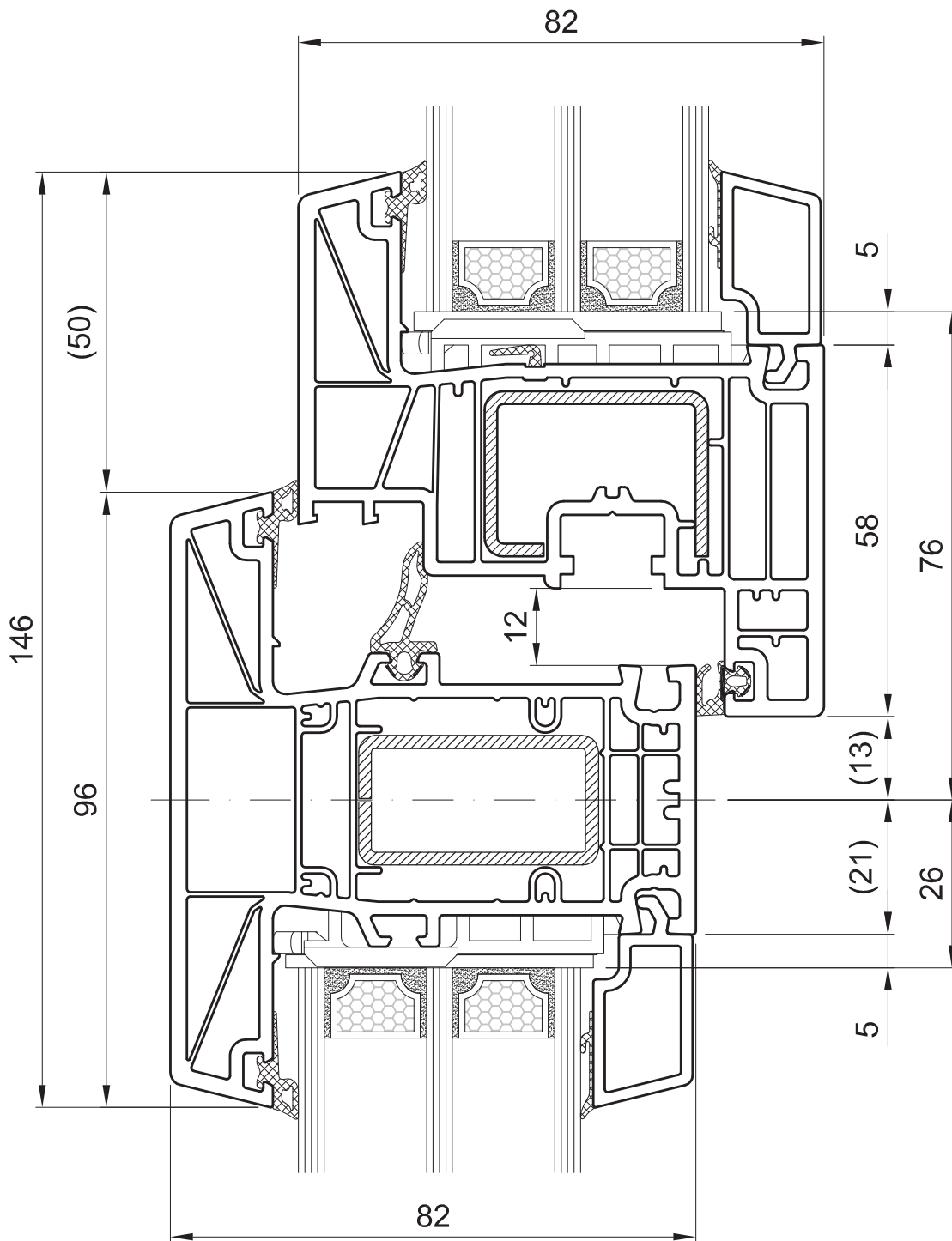

Słupek stały ze szkleniem i skrzydłem okiennym



Cadre et ouvrant de fenêtre avec meneau fixe



Tussenstijl met beglazing in kader en vleugel



Fester Pfosten mit Festverglasung und Flügel



Montante fisso con vetraggio nel telaio e con anta



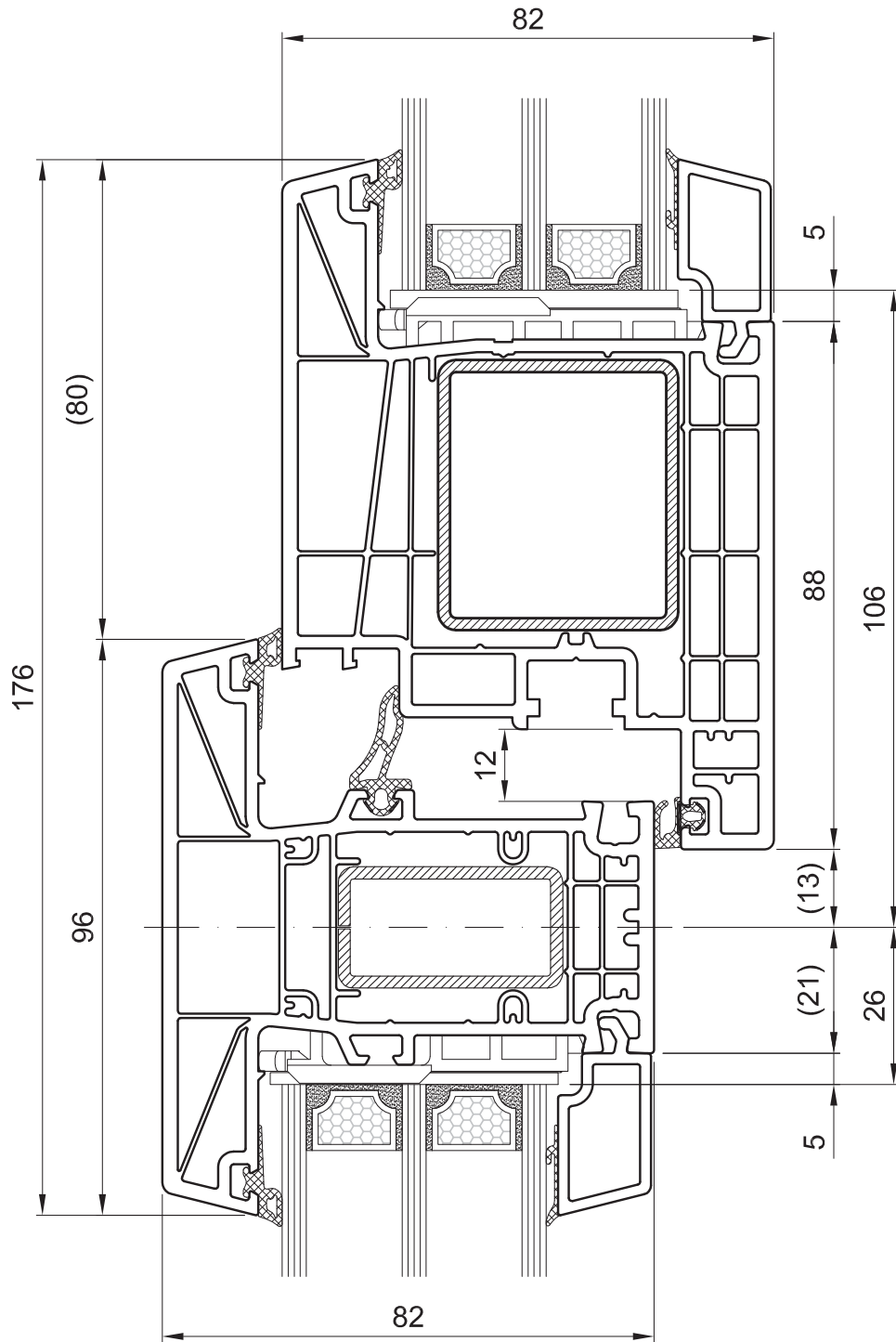

Słupki stały ze szkleniem i skrzydłem tarasowym



Cadre de porte de passage avec meneau fixe



Tussenstijl met beglazing in kader en Terras profiel



Fester Pfosten mit Festverglasung und Terrassentür



Montante fisso con vetraggio nel telaio con portaveranda





BluEvolution 82 **bE**

HO9320 - HP8550

**OKO
OKNA**

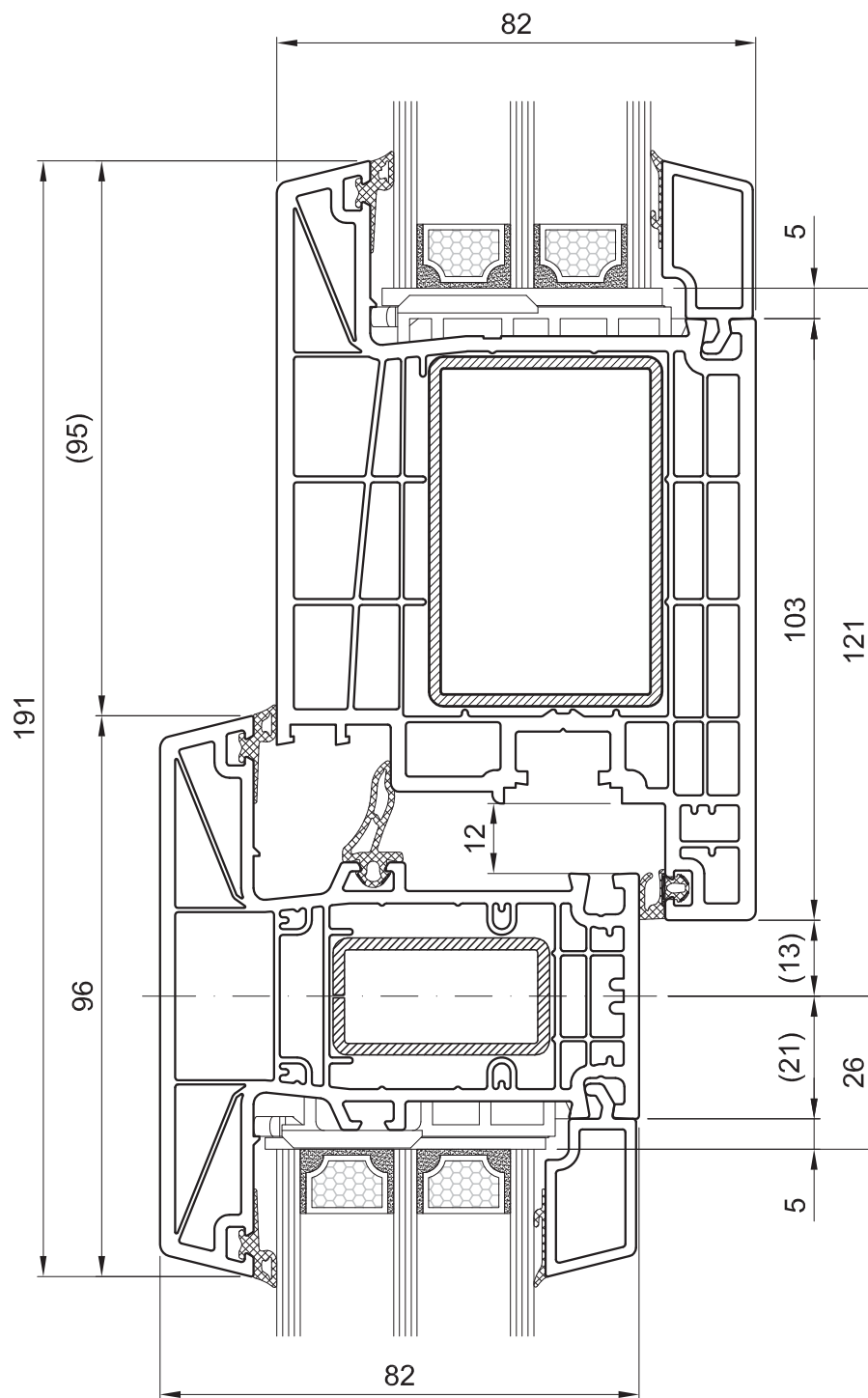

Słupek stały ze szkleniem i skrzydłem drzwiowym



Cadre de porte d'entrée avec meneau fixe



Tussenstijl met beglazing in kader en deur









Fester Pfosten mit Festverglasung und Eingangstür

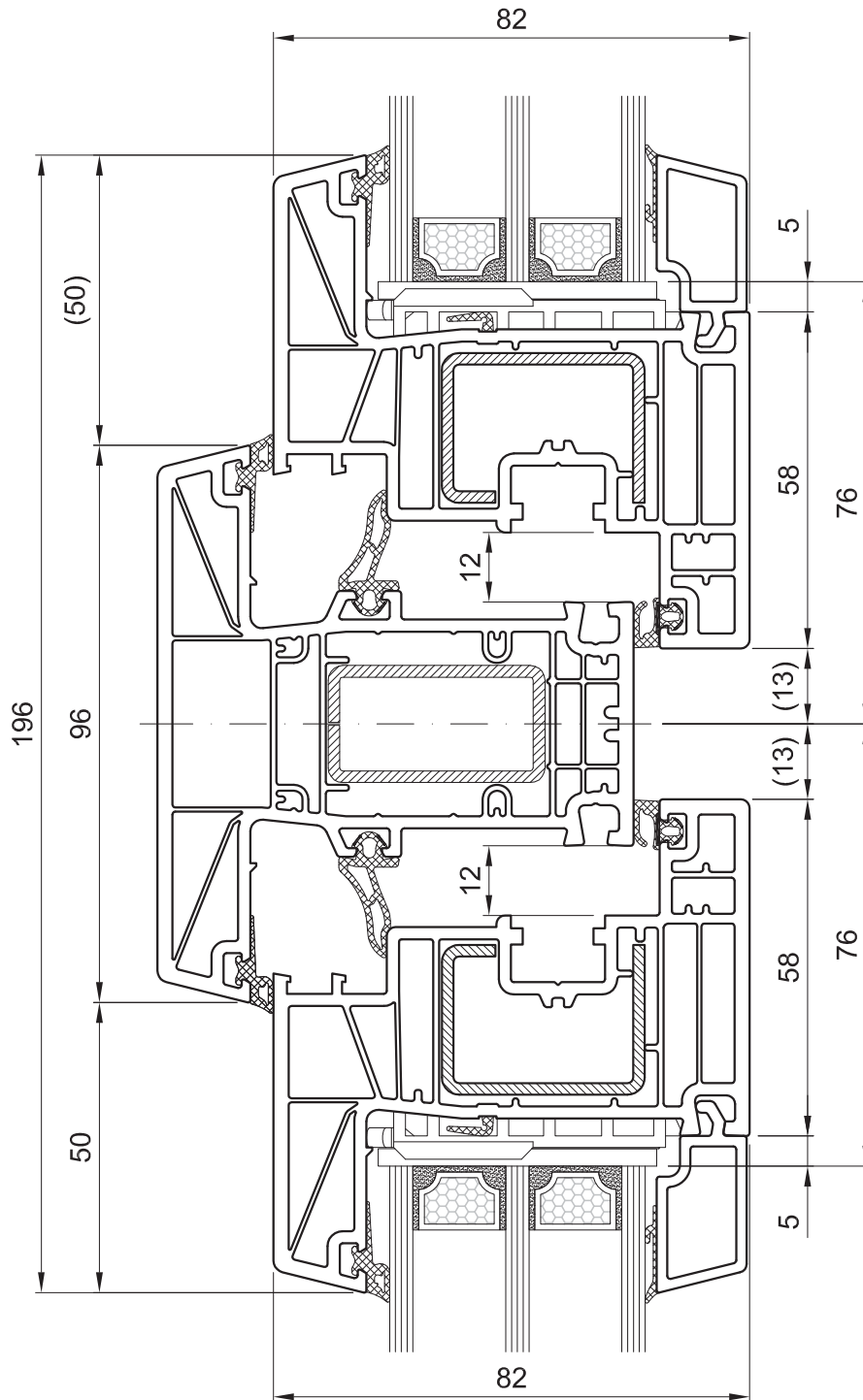

Montante fisso con vetraggio nel telaio con porta d'ingresso





-  Słupek stały (standard 96 mm) z dwoma skrzydłami okiennymi, Classic-line
-  Coupe meneau fixe (standard de 96 mm) avec deux ouvrants, Classic-line
-  Doorsnede, vaste stijl (std 96 mm) met twee vleuels, Classic-line
-  Längsschnitt fester Pfosten (std 96 mm) mit zwei Flügeln, Classic-line
-  Sezione del montante fisso (standard 96 mm) con due ante, Classic-line





BluEvolution 82 **bE**

HO8530 - HO9320 - HO8530

**OKO
OKNA**

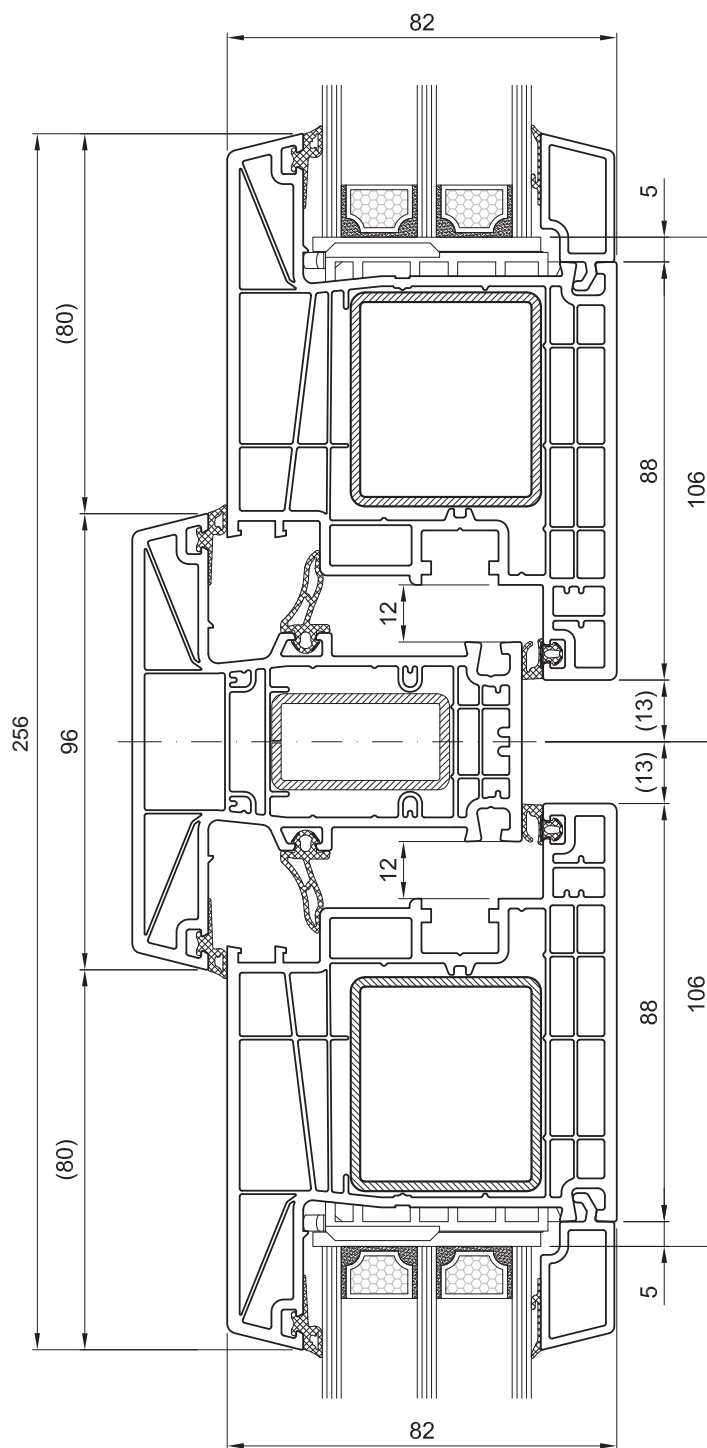

Słupek stały 96 mm z dwoma skrzydłami tarasowymi, otwierane do wewnątrz

Coupe profil de passage, deux ouvrants, ouverture vers l'intérieur avec meneau fixe de 96 mm

Doorsnede terras profiel, twee vleugels naar binnen opendraaiend met vaste stijl 96 mm

Längsschnitt Terrassentür mit zwei Flügeln, nach Innen öffnend mit festem Pfahl 96 mm

Sezione della portaveranda a due ante, l'apertura verso interno con montante fisso 96 mm



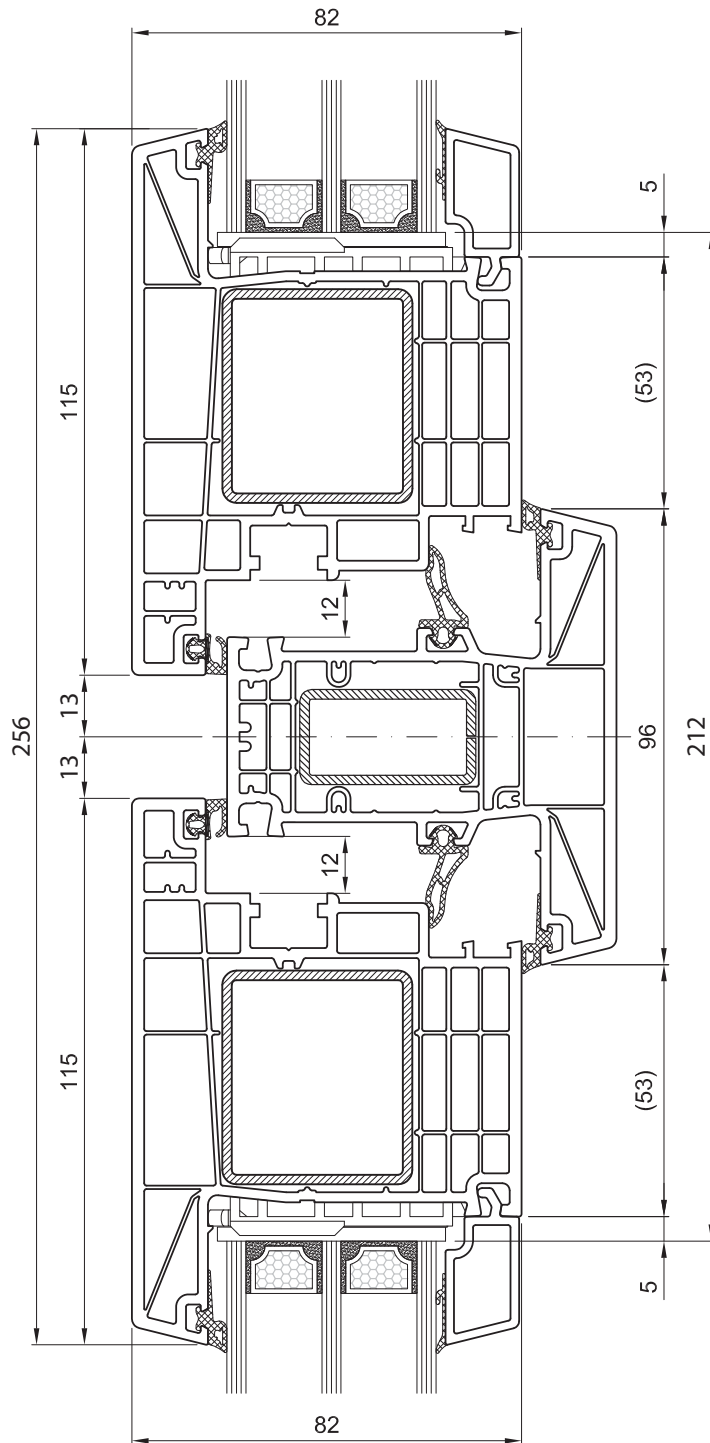
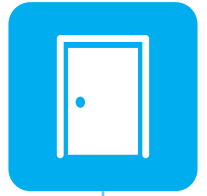

Słupek stały 96 mm z dwoma skrzydłami tarasowymi, otwierane na zewnątrz



Coupe profil de passage, deux ouvrants, ouverture vers l'extérieur avec meneau fixe de 96 mm



Doorsnede terras profiel, twee vleugels naar buiten opendraaiend met vaste stijl 96 mm



Längsschnitt Terrassentür mit zwei Flügeln, nach Aussen öffnend mit festem Pfahl 96 mm



Sezione della portaveranda a due ante, l'apertura verso esterno con montante fisso 96 mm





BluEvolution 82

HP8550 - HO9320 - HP8550

**OKO
OKNA**

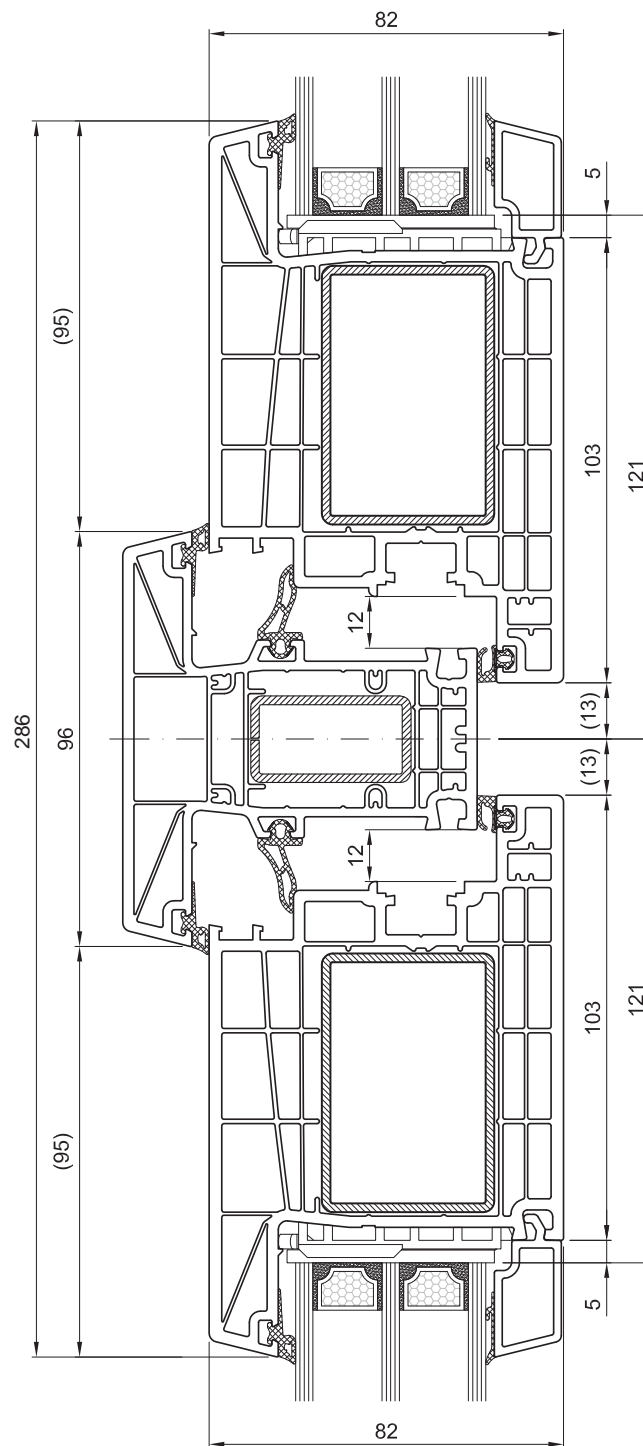

Słupek stały 96 mm z dwoma skrzydłami drzwiowymi, otwierane do wewnątrz

Deux ouvrants de porte avec meneau fixe de 96 mm, ouverture vers l'intérieur

Twee deur vleugels met vaste stijl 96 mm, naar binnen opendraaiend

Zwei Türflügel mit festem Pfahl 96 mm, nach Innen öffnend

Porta a due ante con montante fisso 96 mm, tl'apertura verso interno



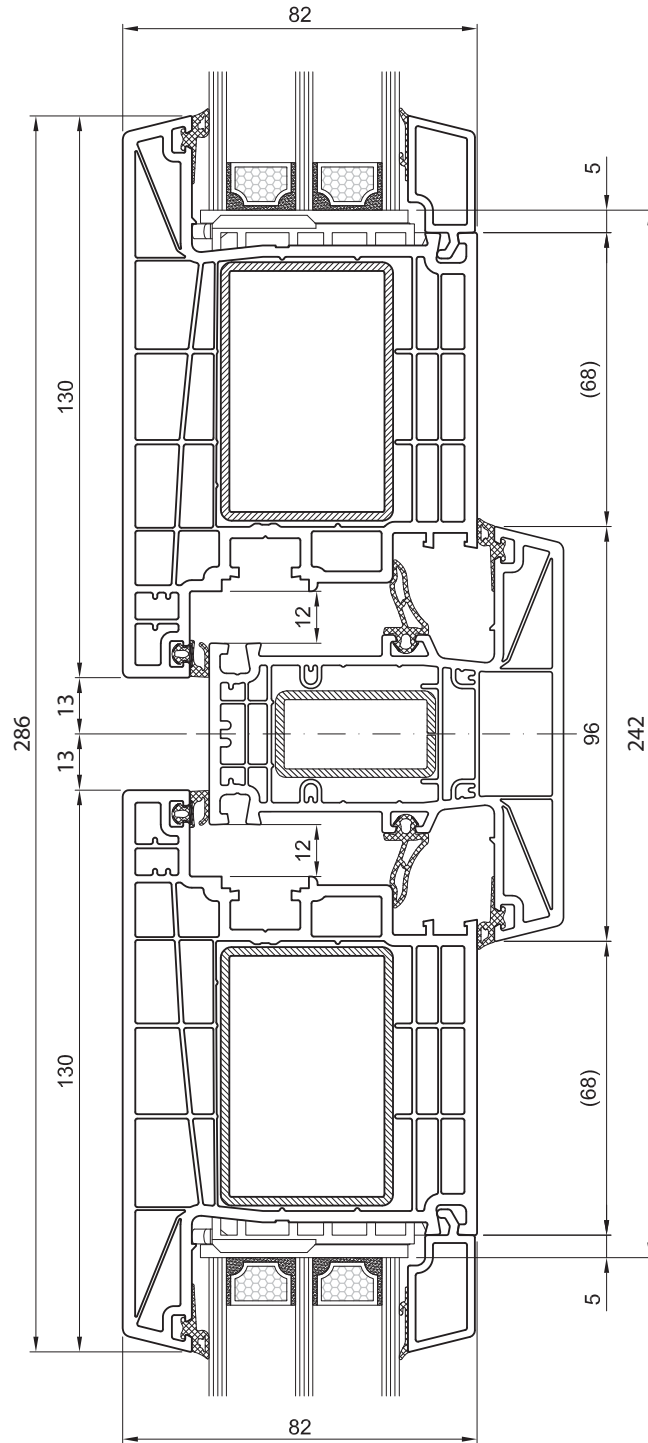
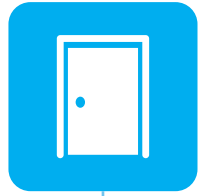

Słupek stały 96 mm z dwoma skrzydłami drzwiowymi, otwierane na zewnątrz



Deux ouvrants de porte avec meneau fixe de 96 mm, ouverture vers l'extérieur



Twee deur vleugels met vaste stijl 96 mm, naar buiten opendraaiend



Zwei Türflügel mit festem Pfahl 96 mm, nach Aussen öffnend



Porta a due ante con montante fisso 96 mm, l'apertura verso esterno



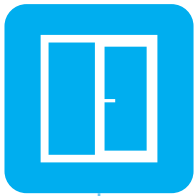

BluEvolution 82 **bE**

HO9320

**OKO
OKNA**

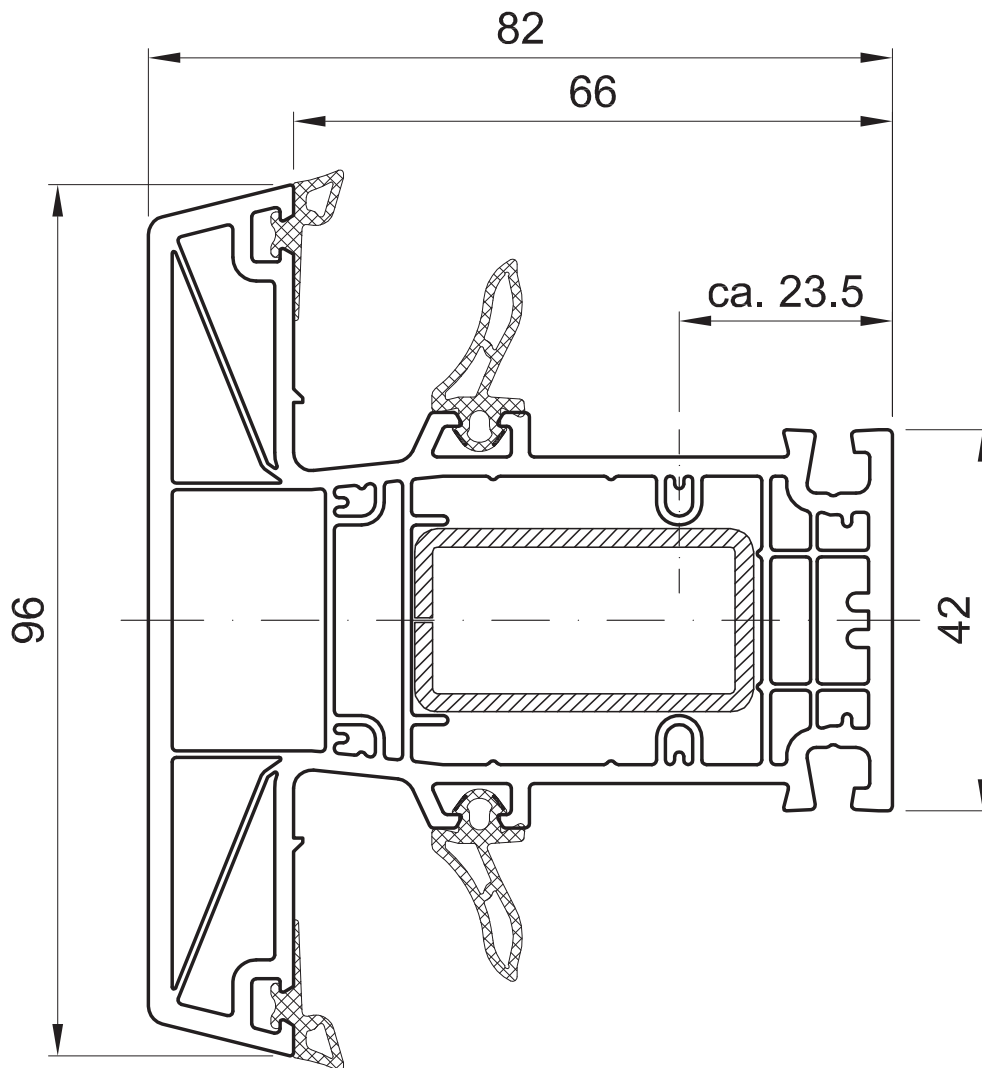

SALAMANDER
WINDOW & DOOR SYSTEMS

Słupek stały 96 mm



Meneau standard de 96 mm



Standaard stijl 96 mm



Fester Pfosten standard 96 mm



Montante standard 96 mm



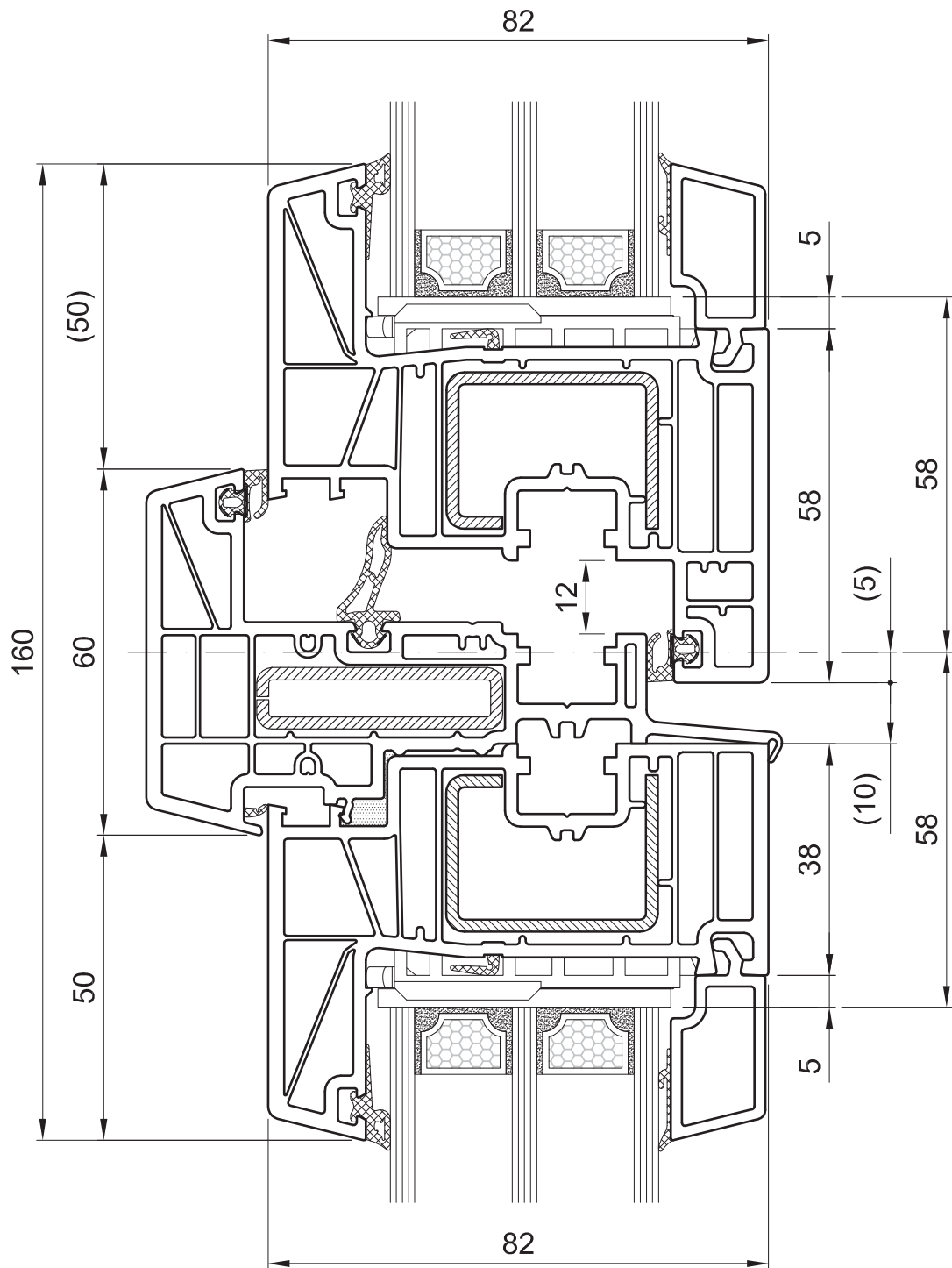

Słupek ruchomy 60 mm z dwoma skrzydłami okiennymi Classic-line



Coupe de deux ouvrants Classic-line, avec meneau mobile de 60 mm



Aansluiting van twee raam vleugels Classic-line met brede stijl 60 mm



Zwei Flügel Classic-line verbunden mit Hilfe eines breiten Stulps mit 60 mm Breite



Guinzione di due ante Classic-line, montante mobile 60 mm





BluEvolution 82 **bE**

HO8530 - HO9810 - HO8530

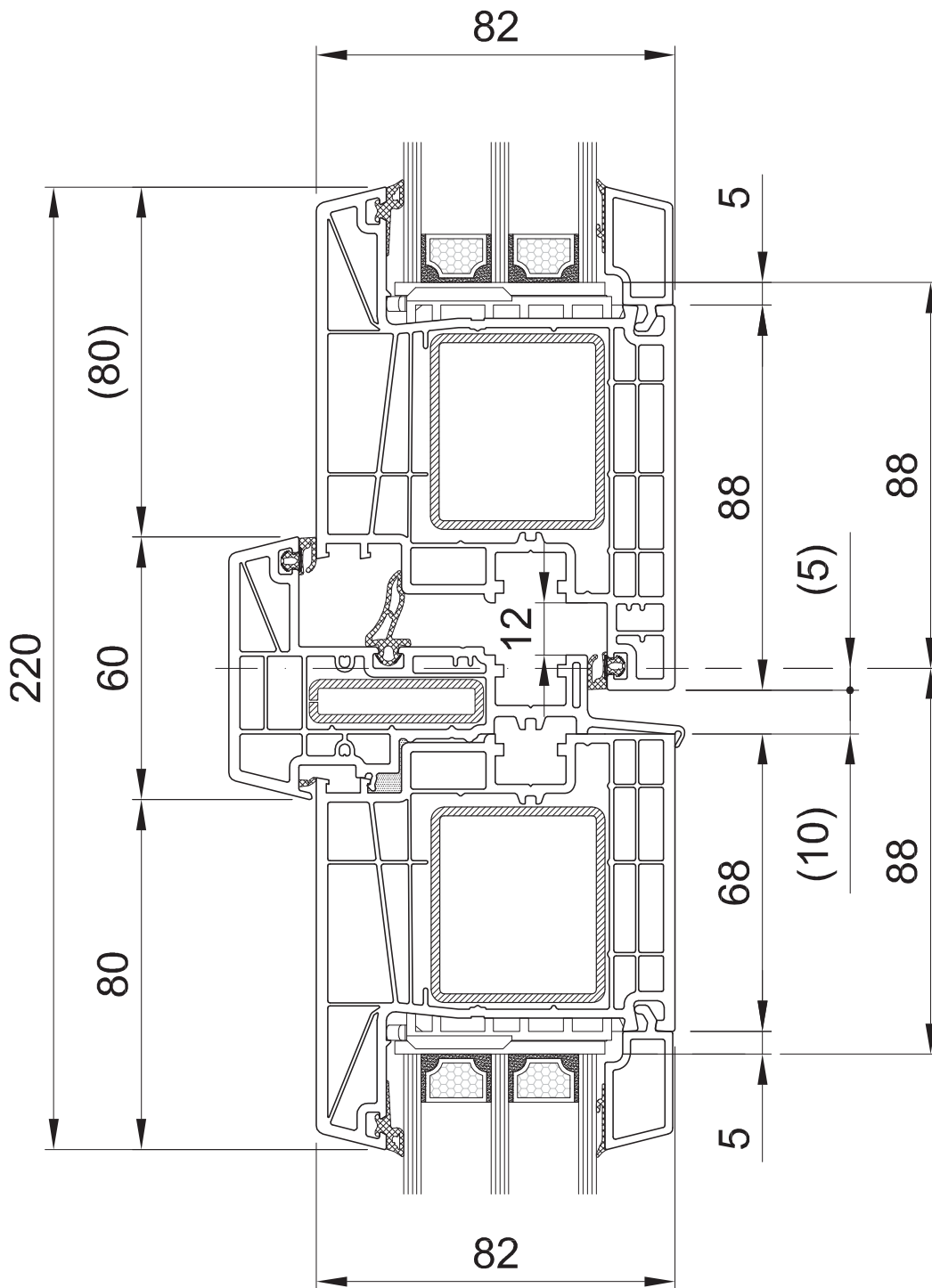

Słupek ruchomy 60 mm z dwoma skrzydłami tarasowymi, otwierane do wewnątrz

Coupe de passage, ouverture vers l'intérieur avec meneau mobile de 60 mm

Aansluiting terras profiel, naar binnen opendraaiend met brede stijl 60 mm

Zwei Terrassenflügel, nach Innen öffnend mit Hilfe eines breiten Stulps mit 60 mm Breite

Guinzione della portaveranda a due ante, l'apertura verso interno con montante mobile 60 mm



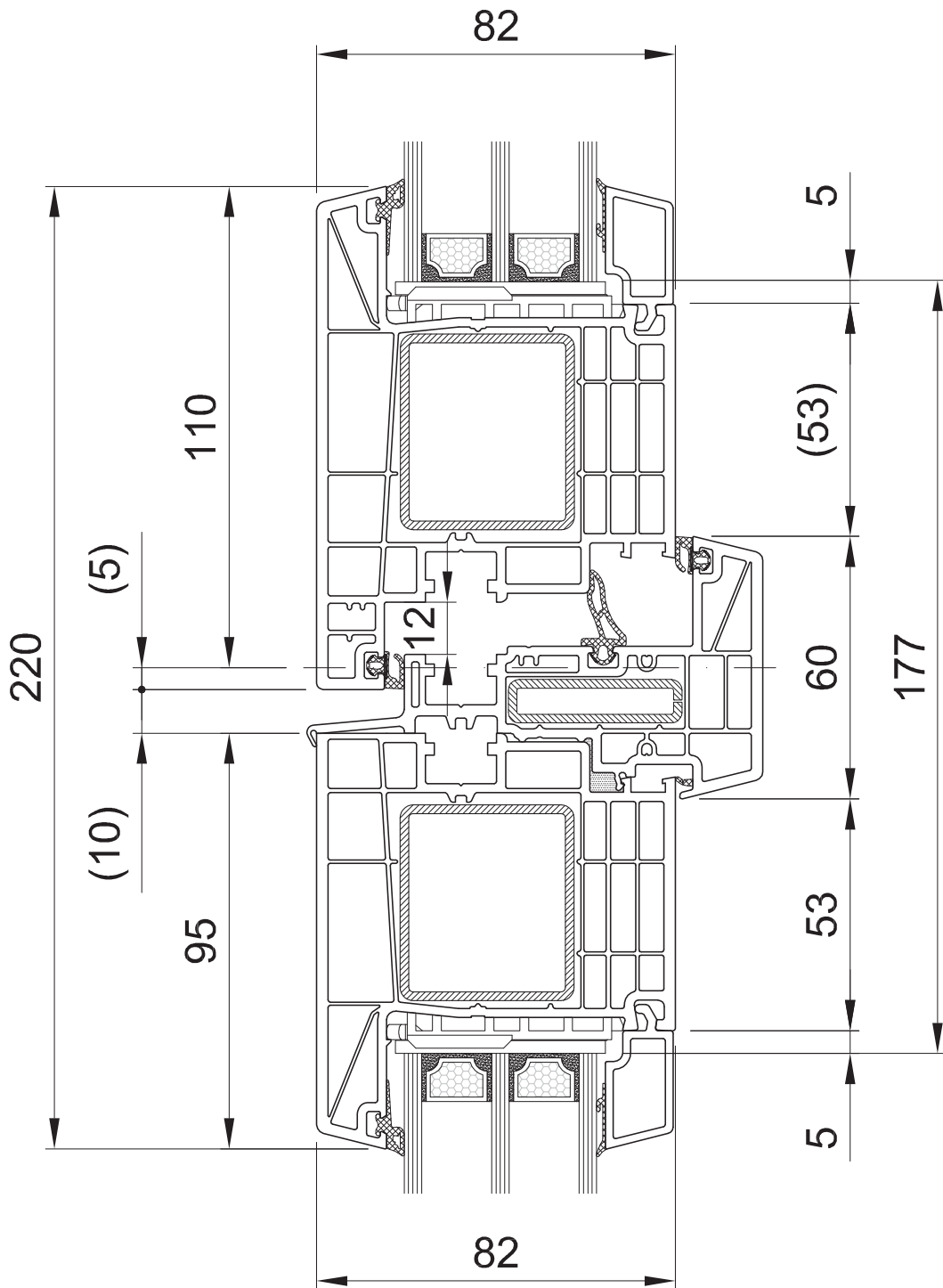

Słupek ruchomy 60 mm z dwoma skrzydłami tarasowymi, otwierane na zewnątrz



Coupe de passage, ouverture vers l'extérieur avec meneau mobile de 60 mm



Aansluiting terras profiel, naar buiten opendraaiend met brede stijl 60 mm



Zwei Terrassenflügel, nach Aussen öffnend mit Hilfe eines breiten Stulps mit 60 mm Breite



Guinzione della portaveranda a due ante, l'apertura verso esterno con montante mobile 60 mm



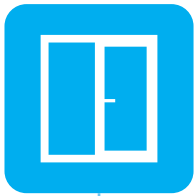



BluEvolution 82 **bE**

HO9810

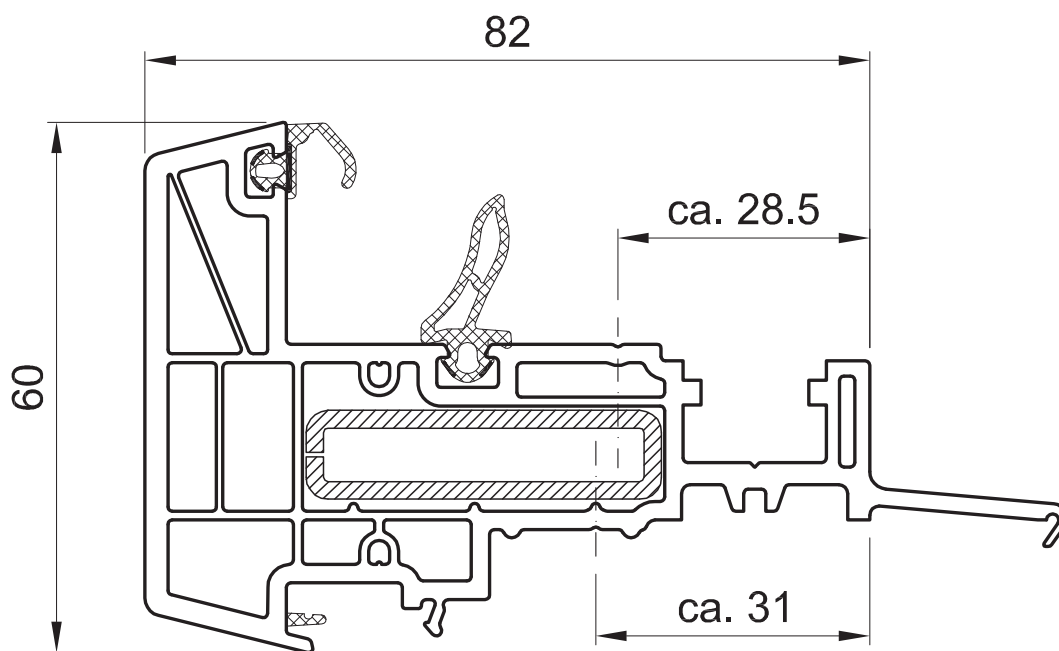
**OKO
OKNA**



Słupek ruchomy 60 mm (wąski) 

Meneau mobile de 60 mm 

Brede stijl 60 mm stulp 

Breiter Stulp 60 mm 

Montante mobile 60 mm 



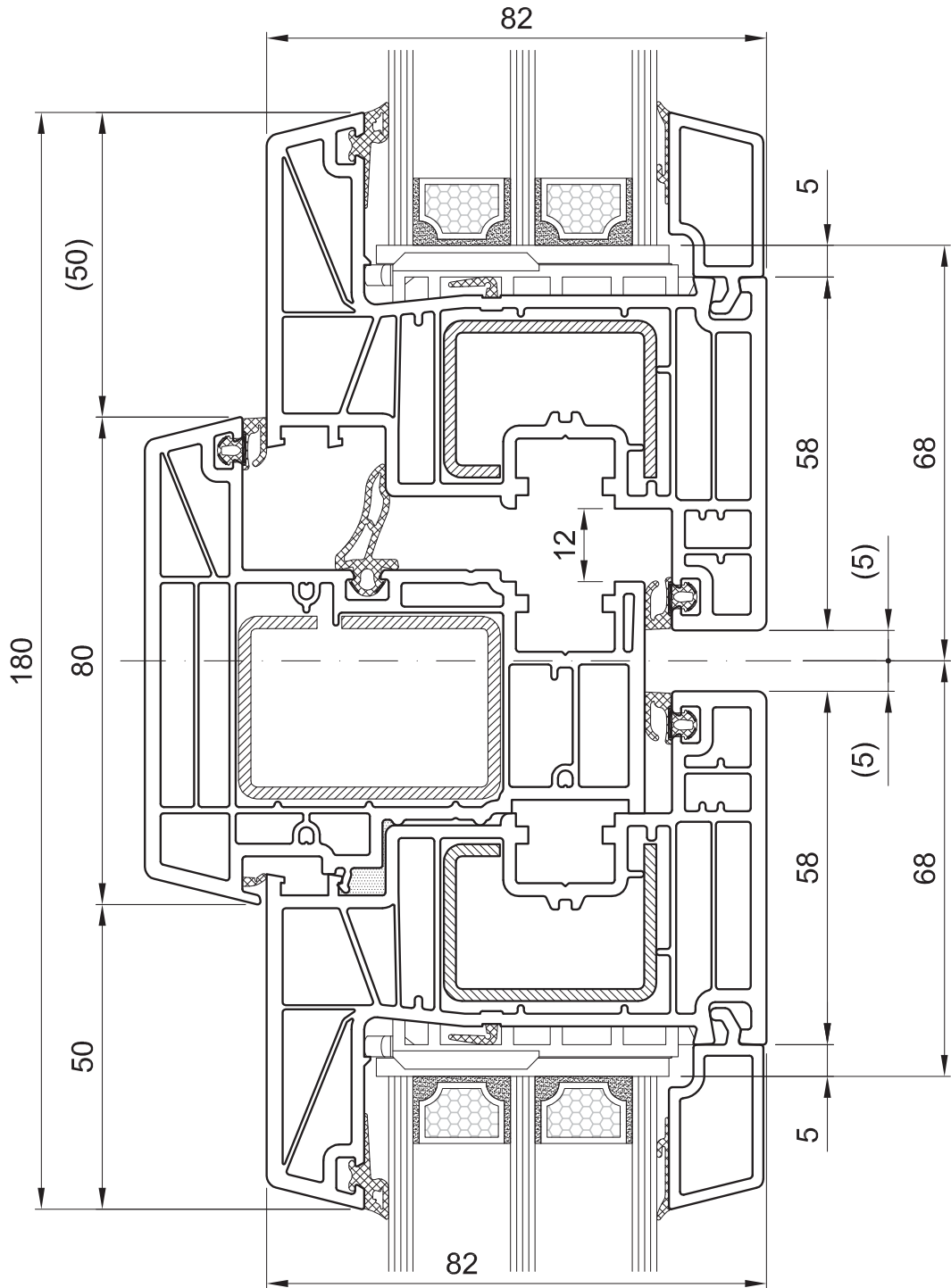

Słupek ruchomy 80 mm z dwoma skrzydłami okiennymi Classic-line



Coupe de deux ouvrants Classic-line, avec meneau mobile de 80 mm



Aansluiting van twee raam vleugels Classic-line met brede stijl 80 mm



Zwei Flügel Classic-line verbunden mit Hilfe eines breiten Stulps mit 80 mm Breite



Guinzione di due ante Classic-line, montante mobile 80 mm





BluEvolution 82 **bE**

HO8530 - HO9800 - HO8530

**OKO
OKNA**

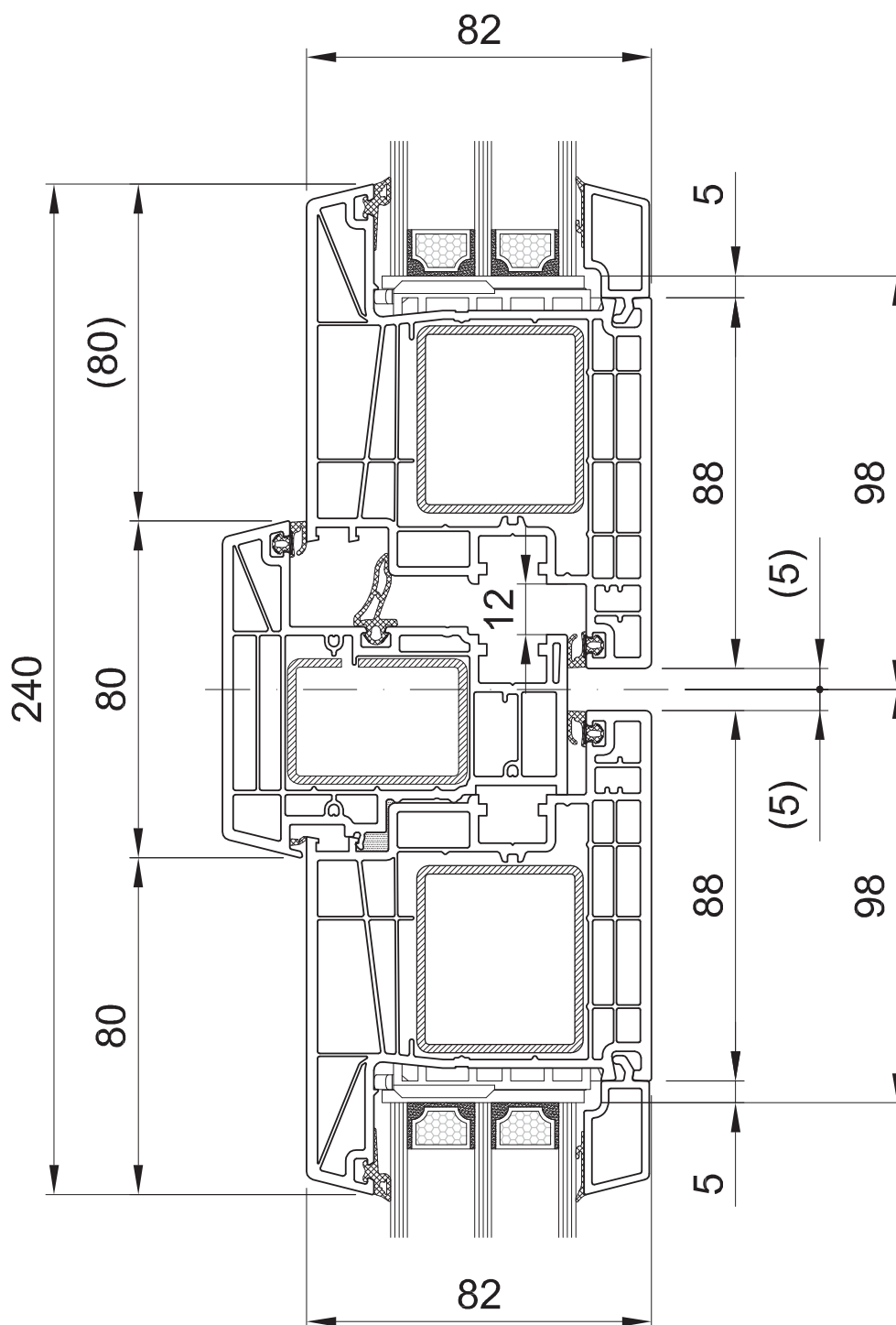

Słupek ruchomy 80 mm z dwoma skrzydłami tarasowymi, otwierane do wewnątrz

Coupe de passage, ouverture vers l'intérieur avec meneau mobile de 80 mm

Aansluiting terras profiel, naar binnen opendraaiend met brede stijl 80 mm

Zwei Terrassenflügel, nach Innen öffnend mit Hilfe eines breiten Stulps mit 80 mm Breite

Guinzione della portaveranda a due ante, l'apertura verso interno con montante mobile 80 mm



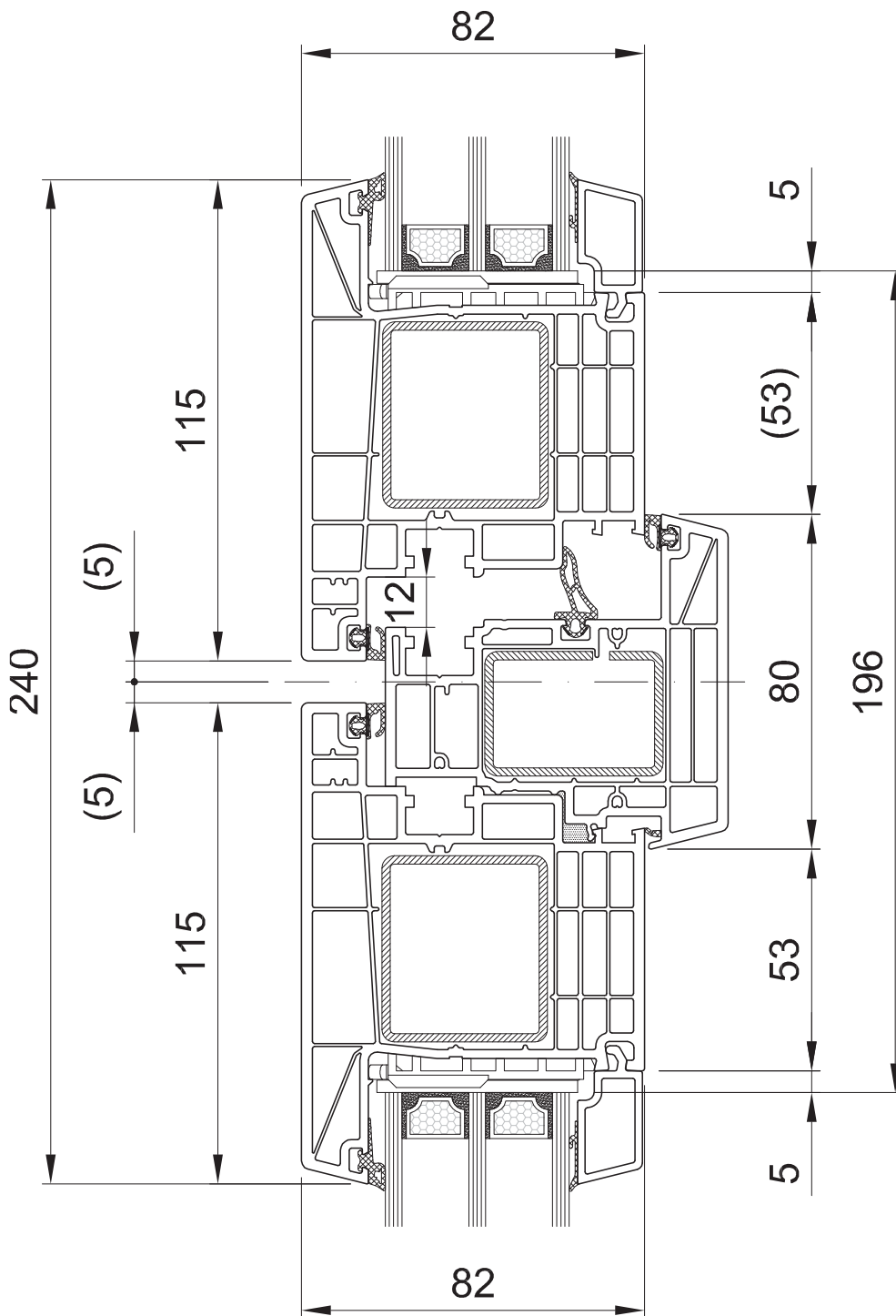
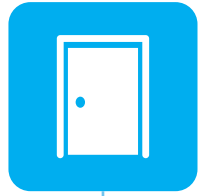

Słupek ruchomy 80 mm z dwoma skrzydłami tarasowymi, otwierane na zewnątrz



Coupe de passage, ouverture vers l'extérieur avec meneau mobile de 80 mm



Aansluiting terras profiel, naar buiten opendraaiend met brede stijl 80 mm



Zwei Terrassenflügel, nach Aussen öffnend mit Hilfe eines breiten Stulps mit 80 mm Breite



Guinzione della portaveranda a due ante, l'apertura verso esterno con montante mobile 80 mm





BluEvolution 82 **bE**

HP8550 - HO9800 - HP8550

**OKO
OKNA**

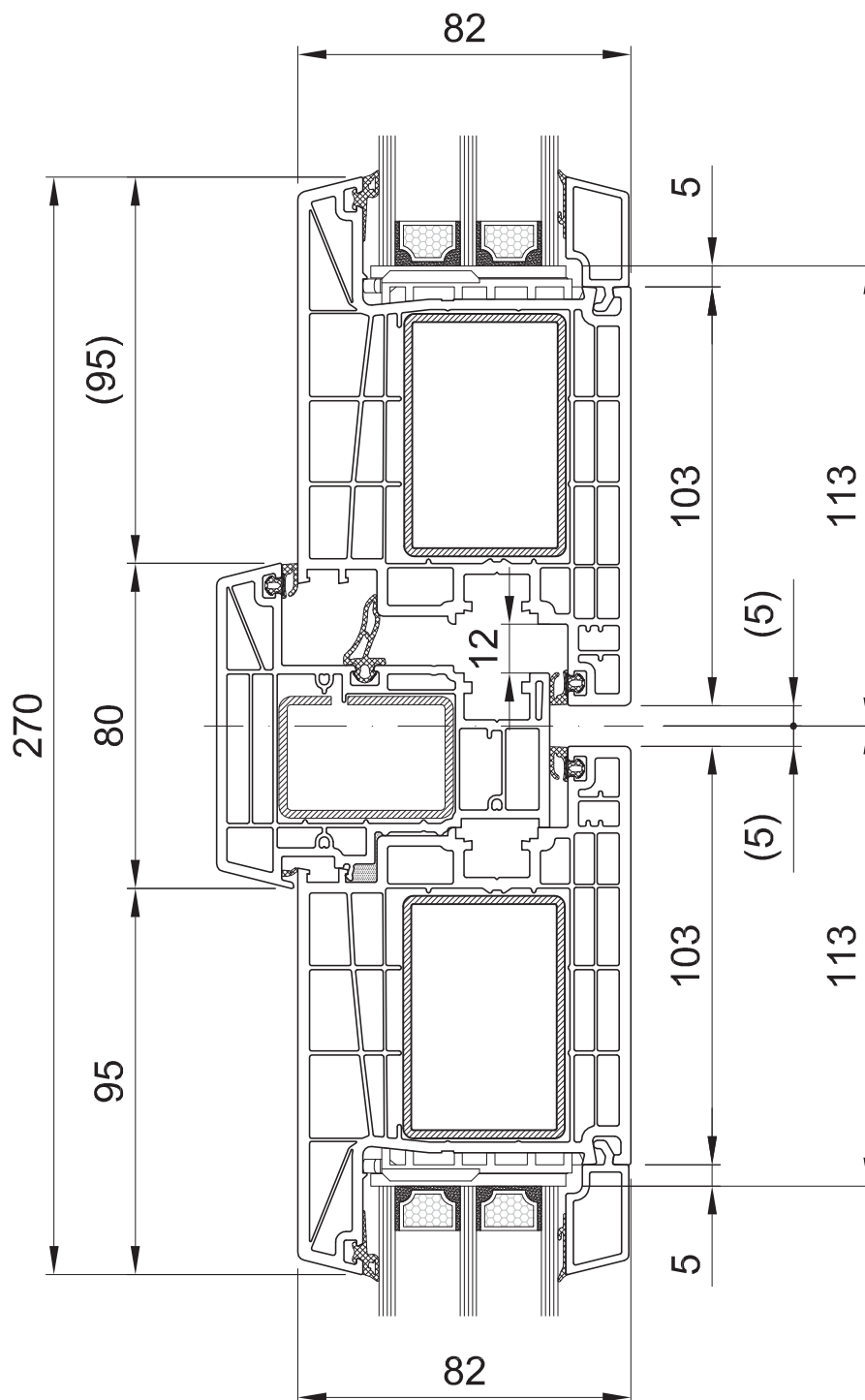

Słupek ruchomy 80 mm z dwoma skrzydłami drzwiowymi, otwierane do wewnątrz

Coupe de porte avec meneau mobile de 80 mm, ouverture vers l'intérieur

Aansluiting deur vleugels met brede stijl 80 mm, naar binnen opendraaiend

Zwei Türflügel mit Hilfe eines breiten Stulps mit 80 mm Breite, nach Innen öffnend

Guinzione porta con montante mobile 80 mm, l'apertura verso interno



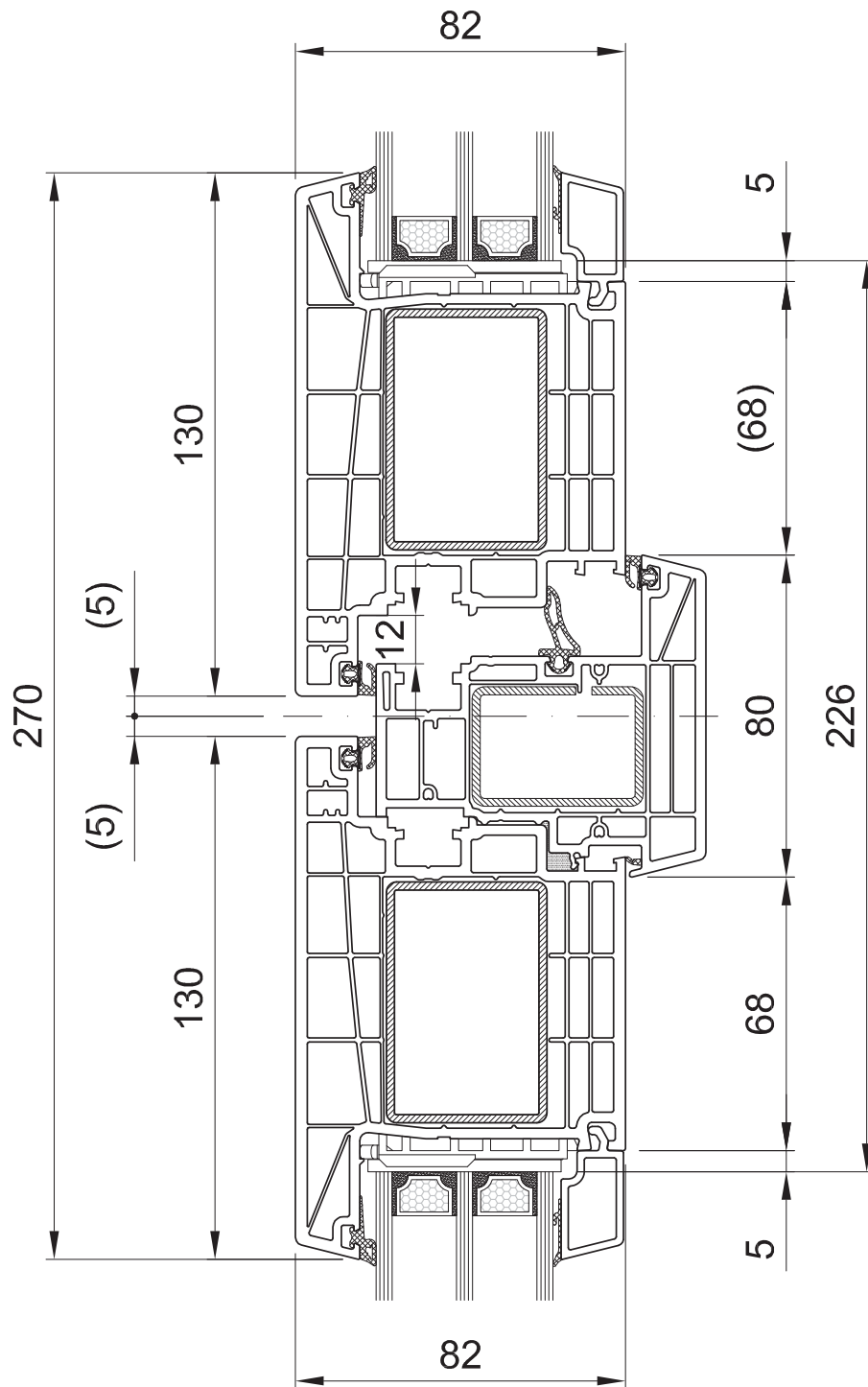
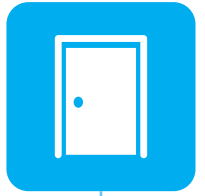

Słupek ruchomy 80 mm z dwoma skrzydłami drzwiowymi, otwierane na zewnątrz



Coupe de porte avec meneau mobile de 80 mm, ouverture vers l'extérieur



Aansluiting deur vleugels met brede stijl 80 mm, naar buiten opendraaiend



Zwei Türflügel mit Hilfe eines breiten Stulps mit 80 mm Breite, nach Aussen öffnend



Guizione porta con montante mobile 80 mm, l'apertura verso esterno





BluEvolution 82 **bE**

HO9800

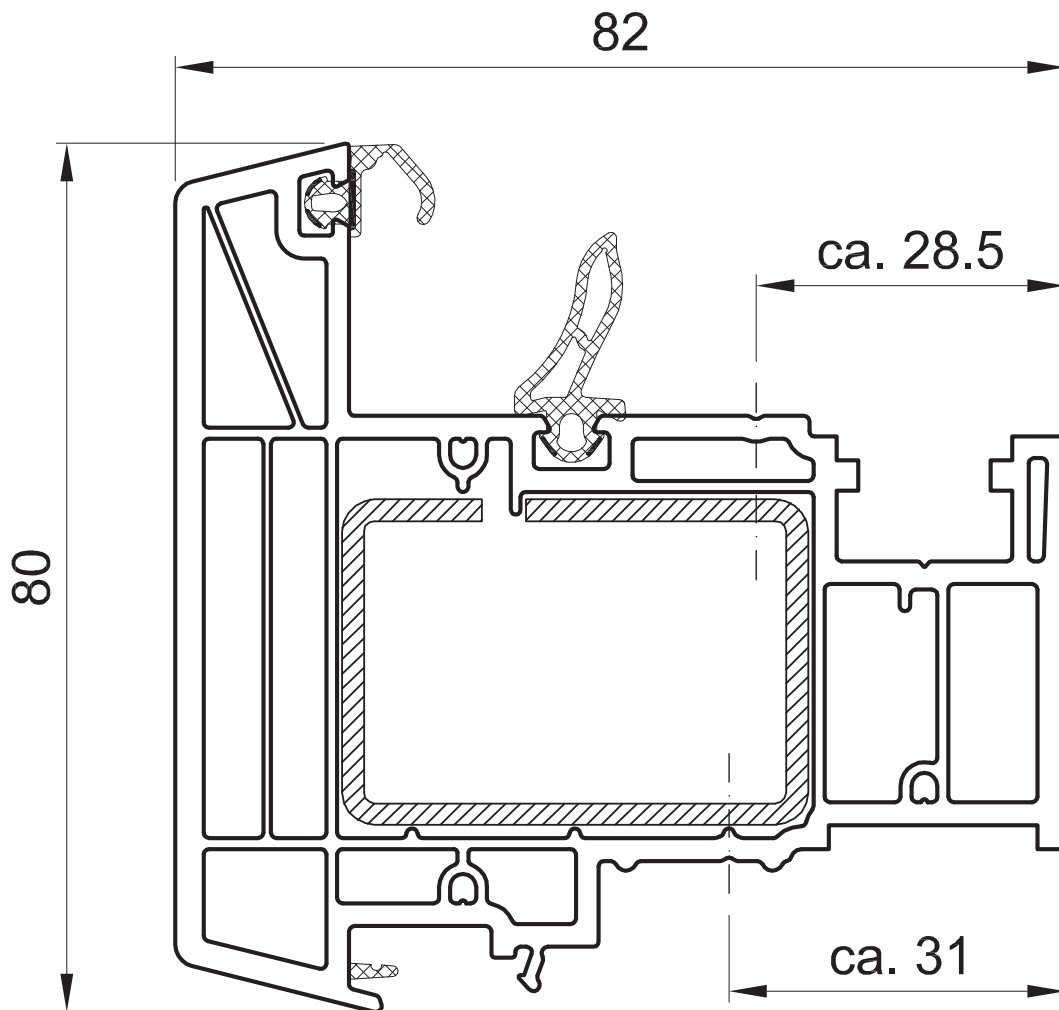

SALAMANDER
WINDOW & DOOR SYSTEMS

Slupek ruchomy 80 mm 

Meneau mobile de 80 mm 

Brede stijl 80 mm stulp 

Breiter Stulp 80 mm 

Montante mobile 80 mm 

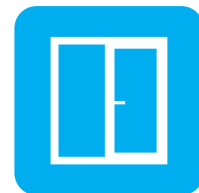

BluEvolution 92 Classic-line



BluEvolution 92 Round-line



BluEvolution 92 | 6 komór | 3 uszczelki

Stal pokazana na rysunku może nie być stalą stosowaną standardowo.



BluEvolution 92 | 6 chambres | 3 joints

Renfort en acier présenté sur le dessin ci-dessus est en option.



BluEvolution 92 | 6 kamers | 3 afdichtingen

Staal die u op de tekening ziet, is niet standaard.



BluEvolution 92 | 6 Kammern | 3 Dichtungen

Der angewendete Stahlkern kann von dem abgebildeten Kern abweichen.



BluEvolution 92 | 6 camere | 3 guarnizioni

L'acciaio presentato sul disegno può essere un acciaio non standard.



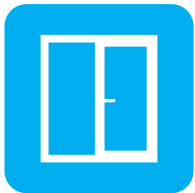

BluEvolution 92 **bE**

170 820 - 171 020

**OKO
OKNA**

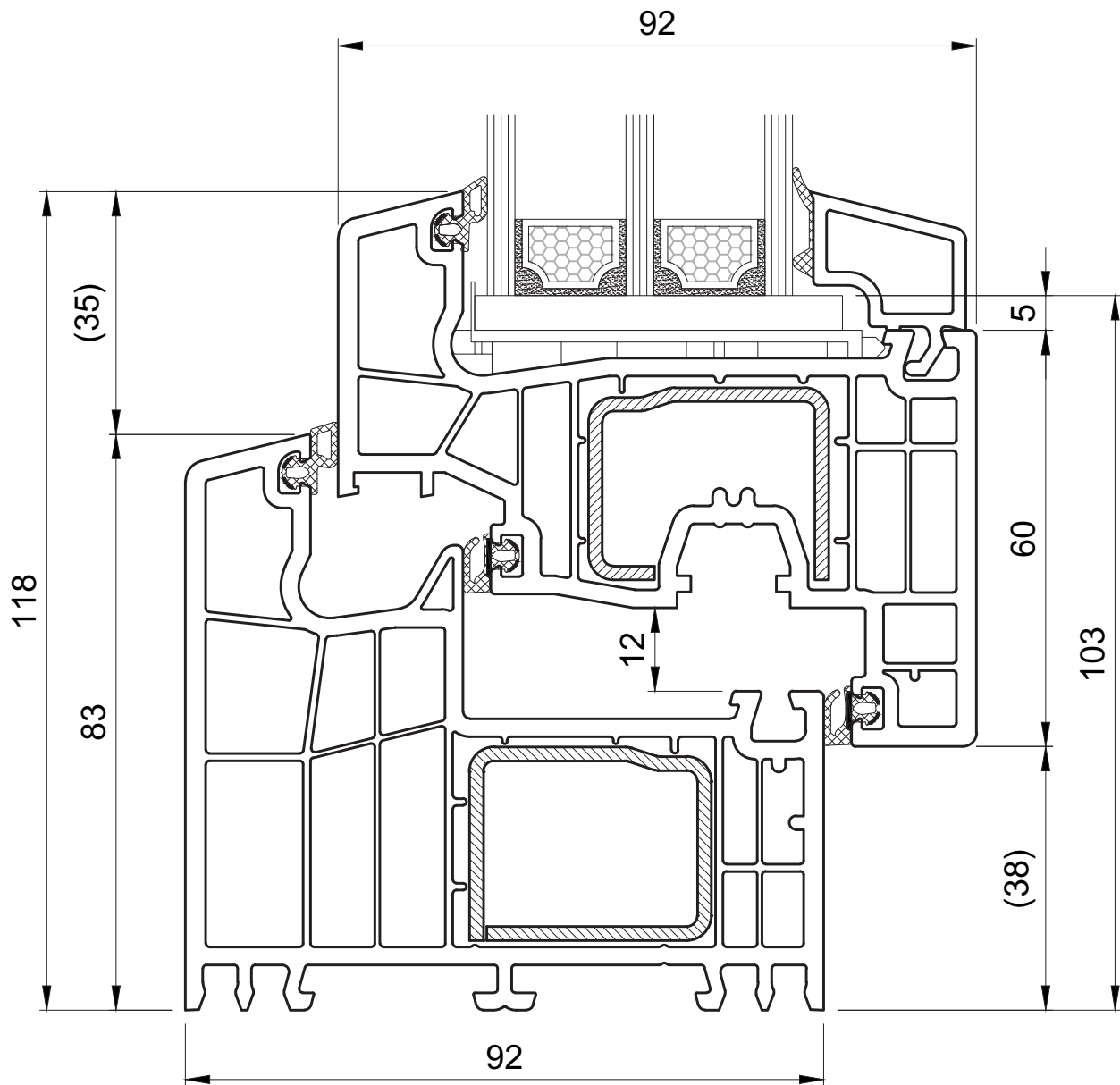

SALAMANDER
WINDOW & DOOR SYSTEMS

Profil okienny Classic-line



Profil de fenêtre Classic-line



Raamprofiel Classic-line



Flügelprofil Classic-line



Profilo finestra Classic-line



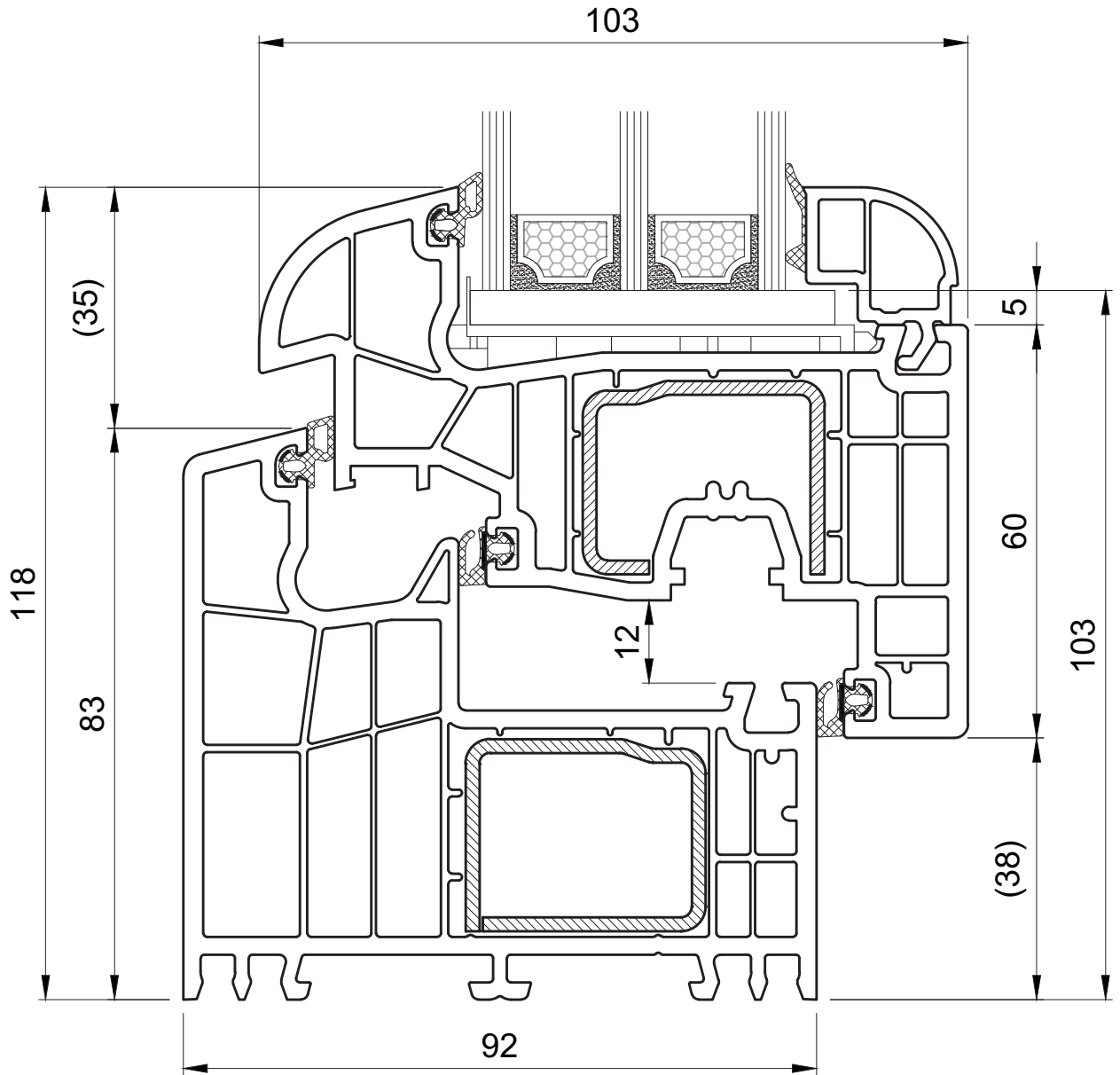

-  Profil okienny Round-line
-  Profil de fenêtre Round-line
-  Raamprofiel Round-line
-  Flügelprofil Round-line
-  Profilo finestra Round-line





BluEvolution 92 **bE**

170 820 - 171 030

**OKO
OKNA**

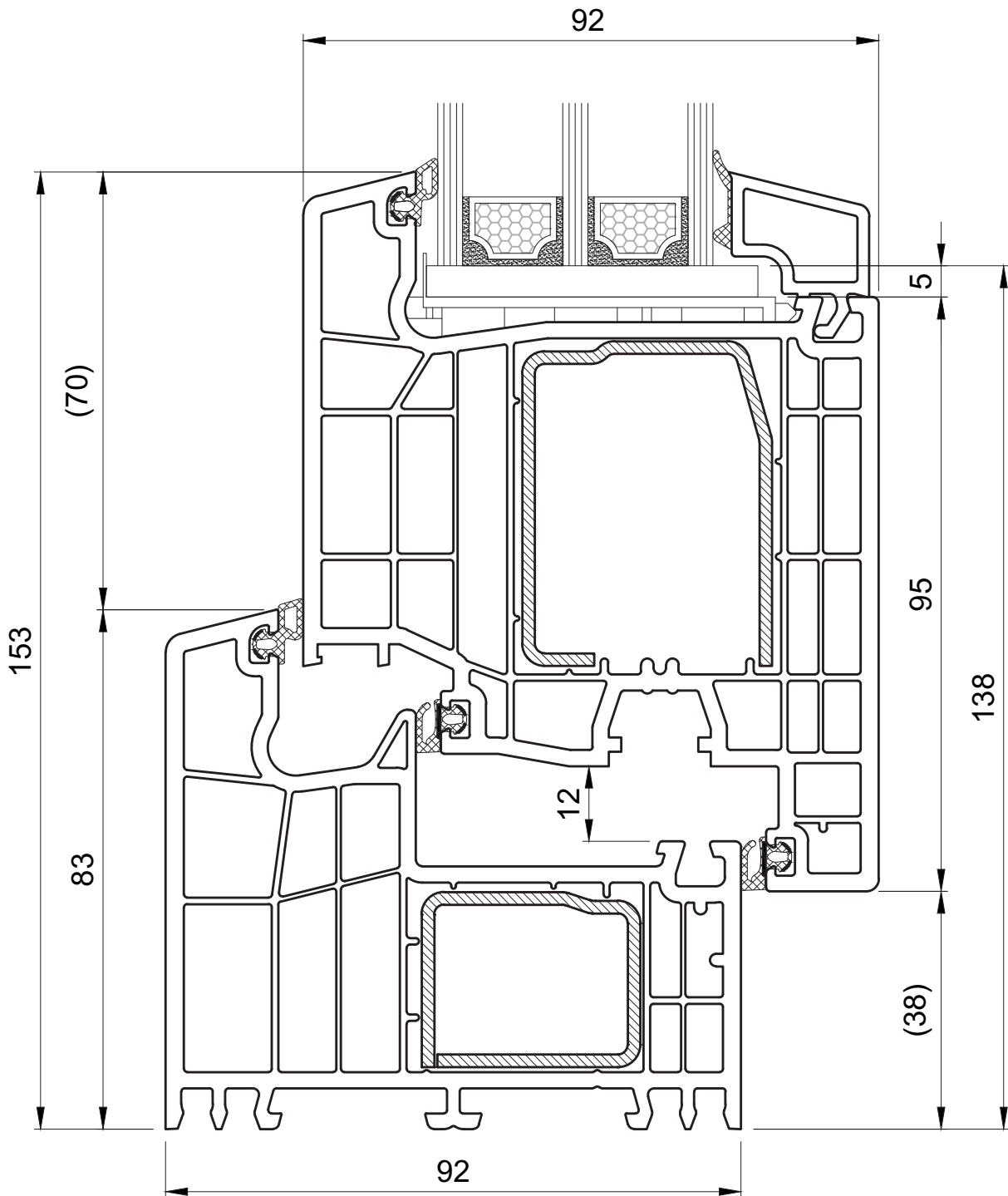

SALAMANDER
WINDOW & DOOR SYSTEMS

Drzwi tarasowe, otwierane do wewnątrz



Porte de passage, ouverture vers l'intérieur



Terras profiel, naar binnen opendraaiend



Terassentür, nach Innen öffnend



Portaveranda, l'apertura verso interno



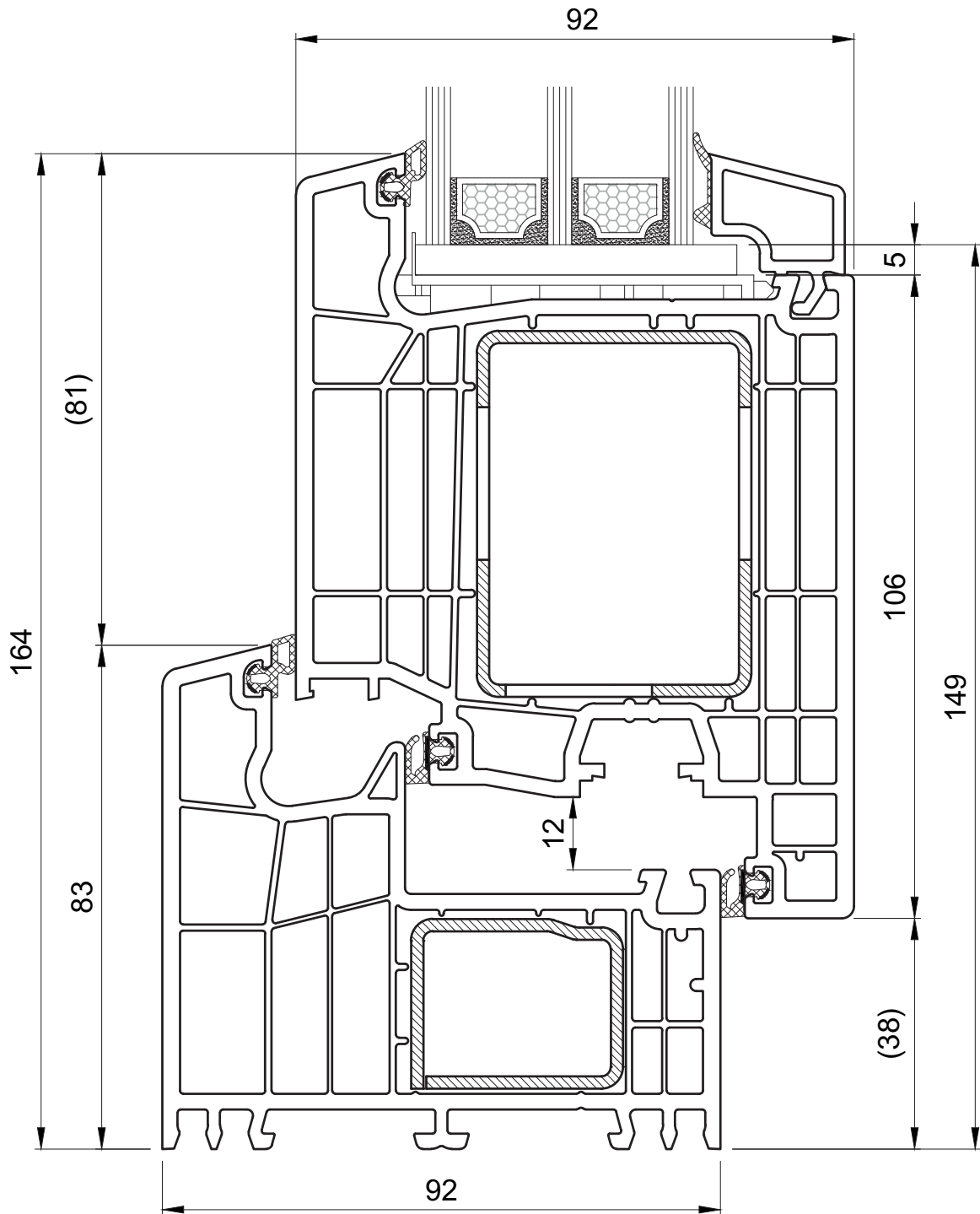

Drzwi wejściowe, otwierane do wewnątrz



Porte d'entrée, ouverture vers l'intérieur



Deur, naar binnen opendraaiend



Eingangstür, nach Innen öffnend



Porta d'ingresso, l'apertura verso interno





BluEvolution 92 **bE**

170 820 - 371 040

**OKO
OKNA**

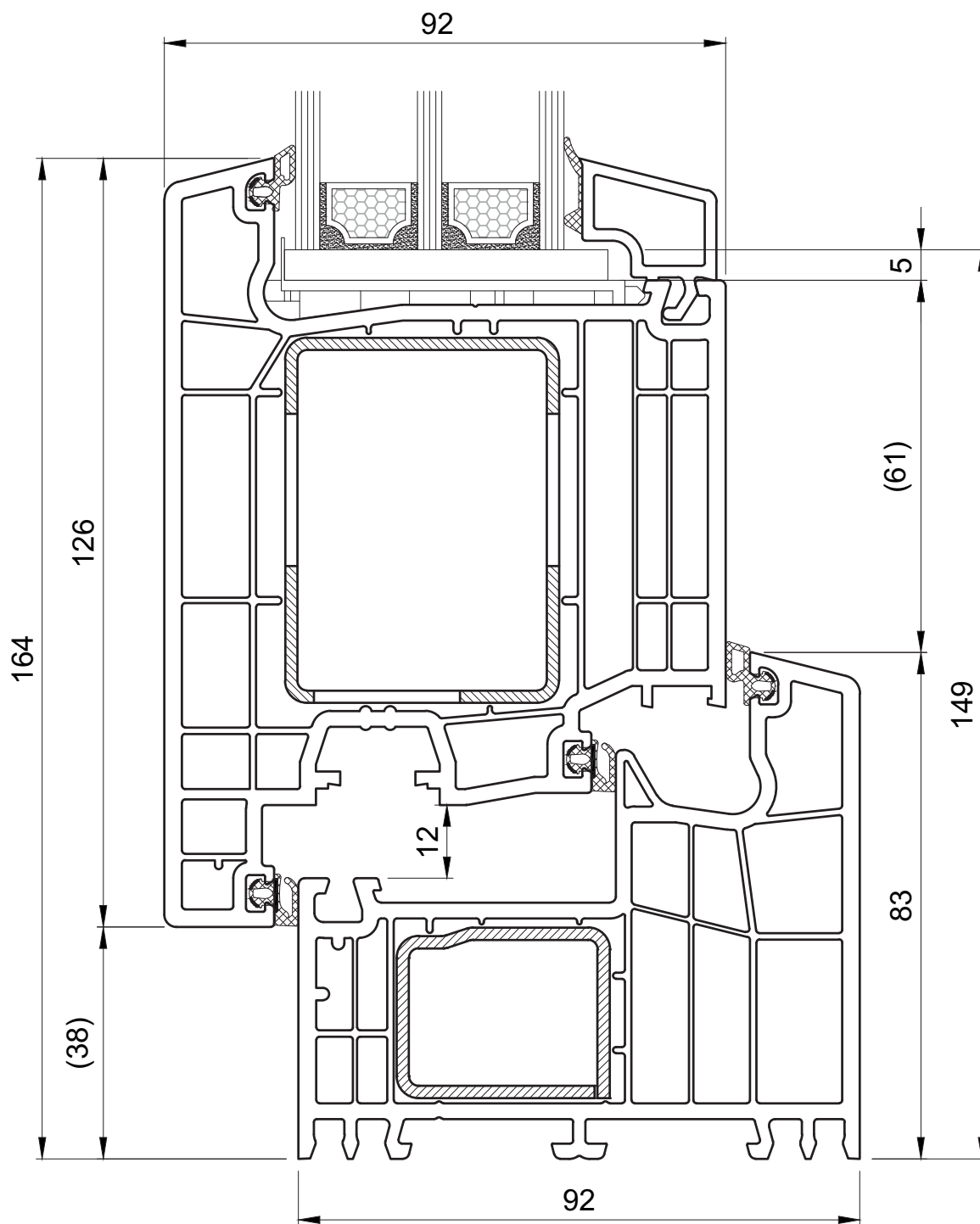

Drzwi wejściowe, otwierane na zewnątrz



Porte d'entrée, ouverture vers l'extérieur



Deur, naar buiten opendraaiend



Eingangstür, nach Aussen öffnend



Porta d'ingresso, l'apertura verso esterno



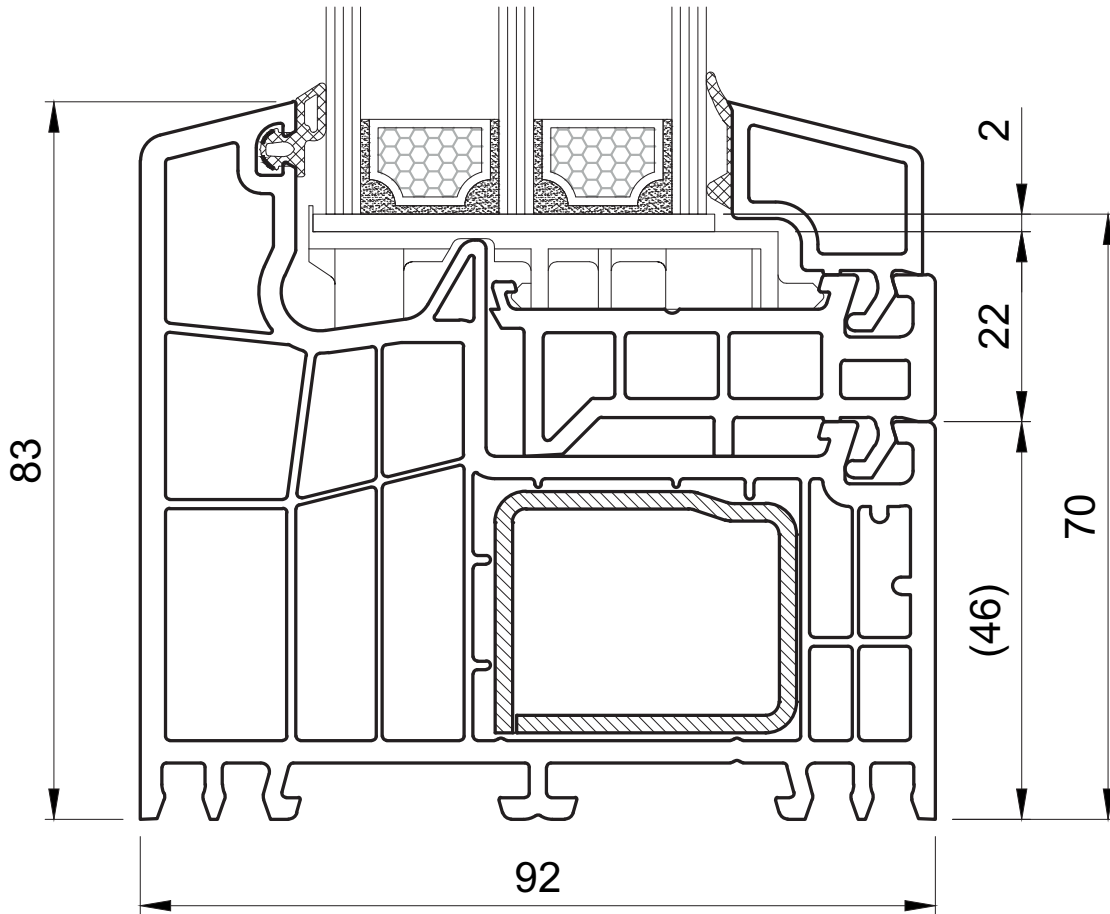
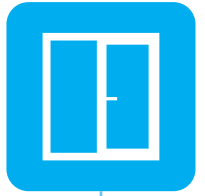

-  Szklenie w ramie
-  Dormant standard
-  Kader standard
-  Standardrahmen
-  Telaio standard





BluEvolution 92 **bE**

170 430 - 171 020

**OKO
OKNA**

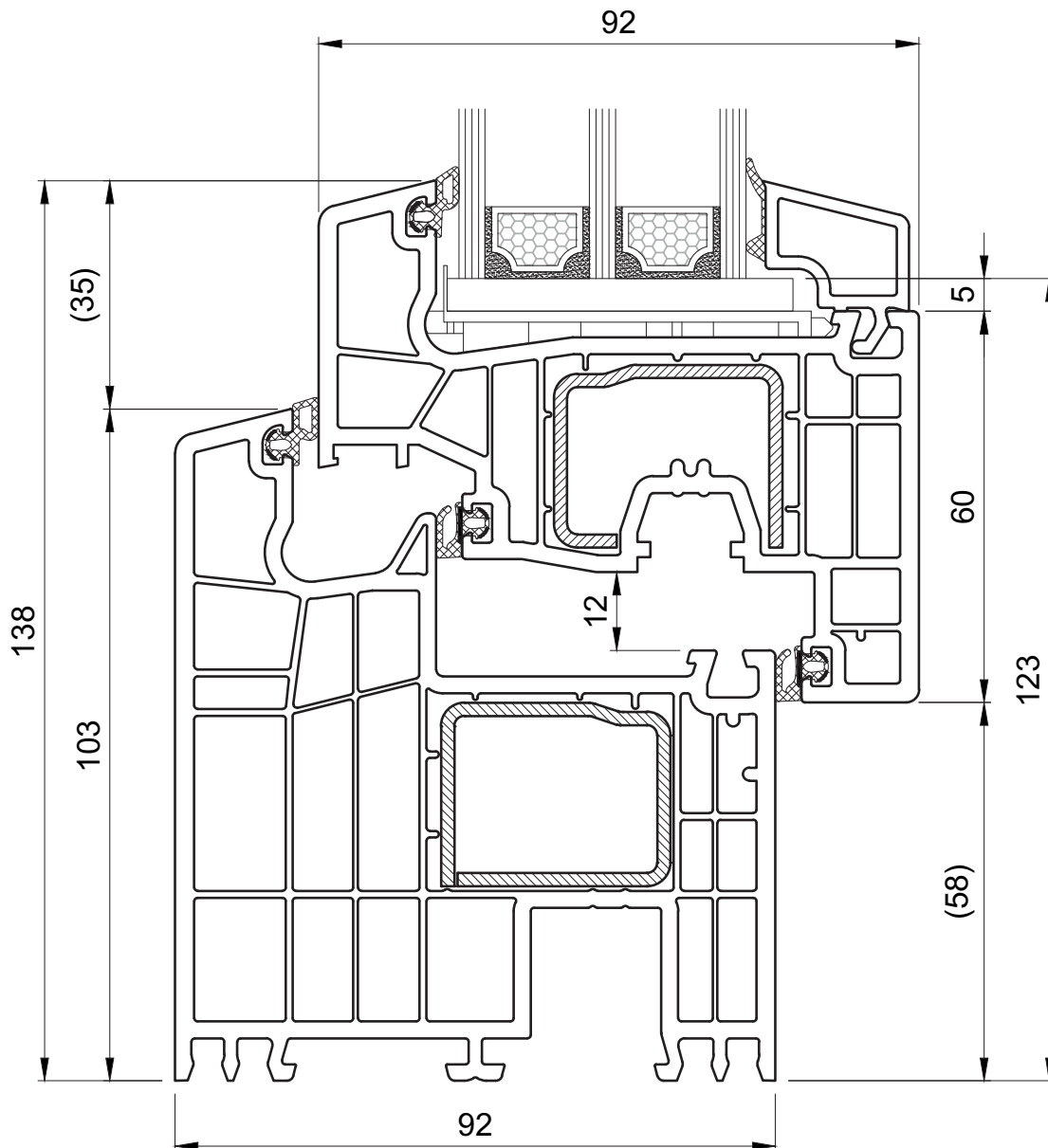

Skrzydło okienne Classic-line z ramą 103 mm



Ouvrant Classic-line avec dormant 103 mm



Vleugel Classic-line + kader 103 mm









Flügel Classic-line mit Rahmen 103 mm

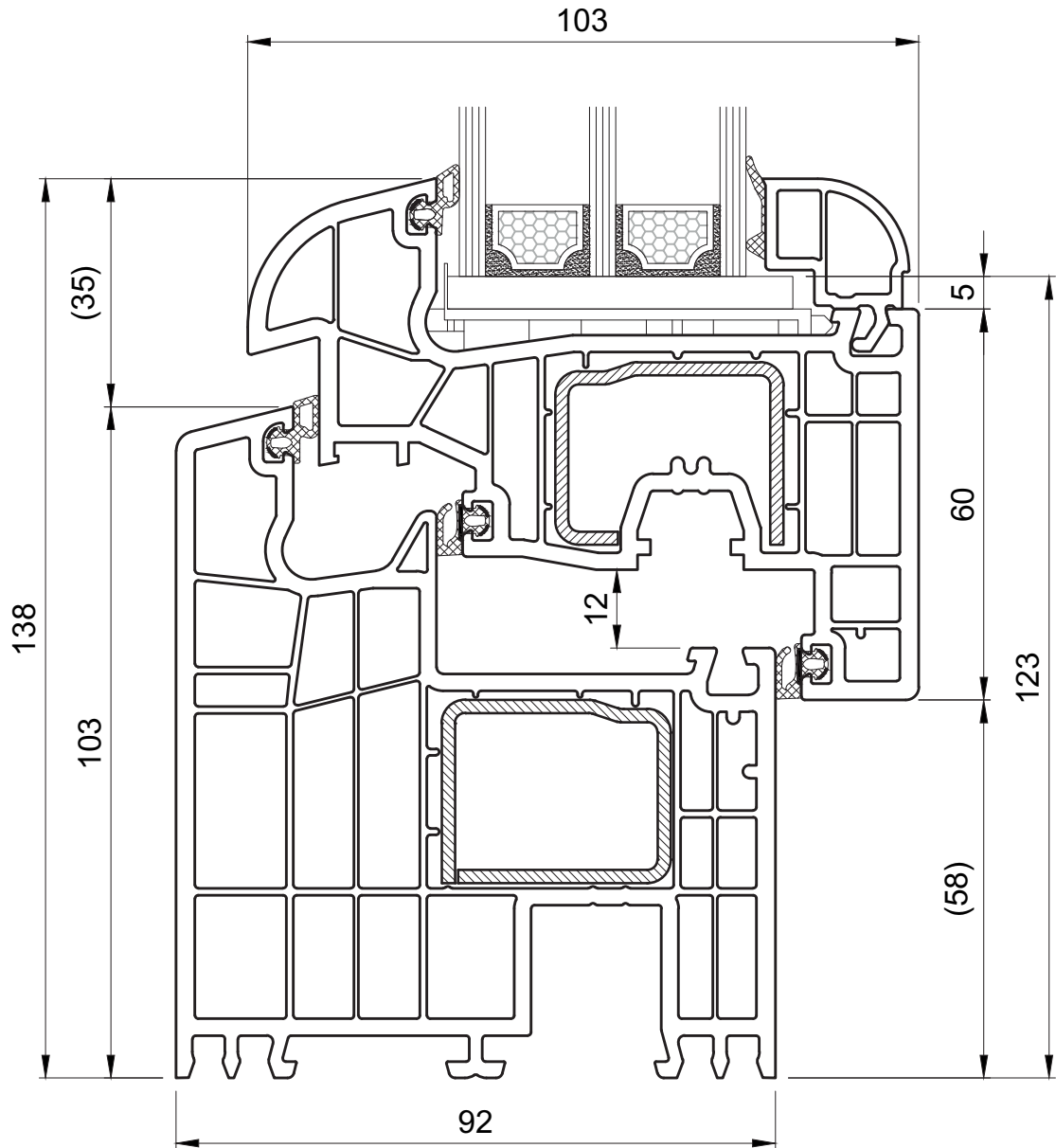

Ante Classic-line con telaio 103 mm





-  Skrzydło okienne Round-line z ramą 103 mm
-  Ouvrant Round-line avec dormant 103 mm
-  Vleugel Round-line + kader 103 mm
-  Flügel Round-line mit Rahmen 103 mm
-  Ante Round-line con telaio 103 mm





BluEvolution 92 **bE**

170 430 - 171 030

**OKO
OKNA**

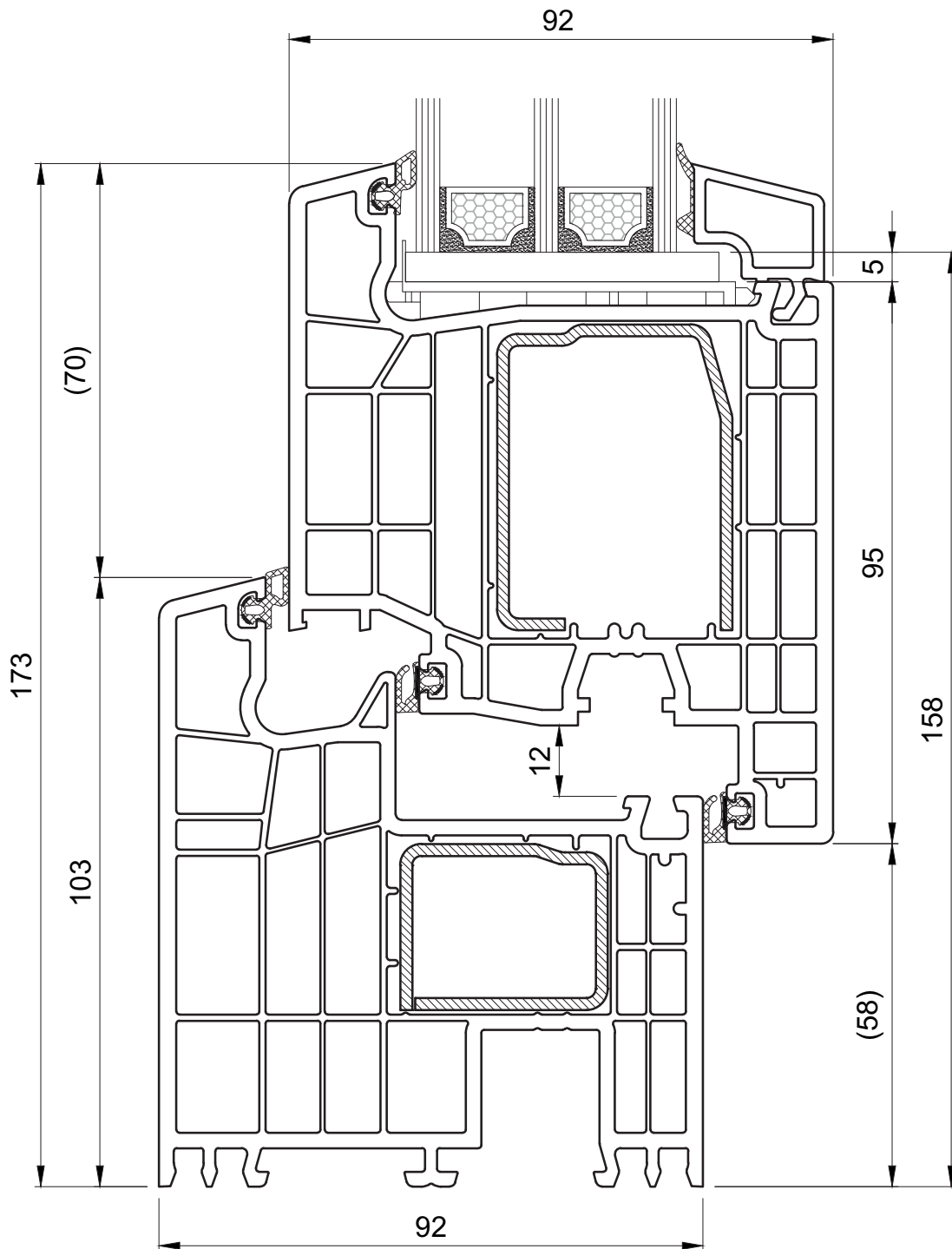

SALAMANDER
WINDOW & DOOR SYSTEMS

Drzwi tarasowe, otwierane do wewnątrz

Porte de passage, ouverture vers l'intérieur

Terras profiel, naar binnen opendraaiend

Terassentür, nach Innen öffnend

Portaveranda, l'apertura verso interno



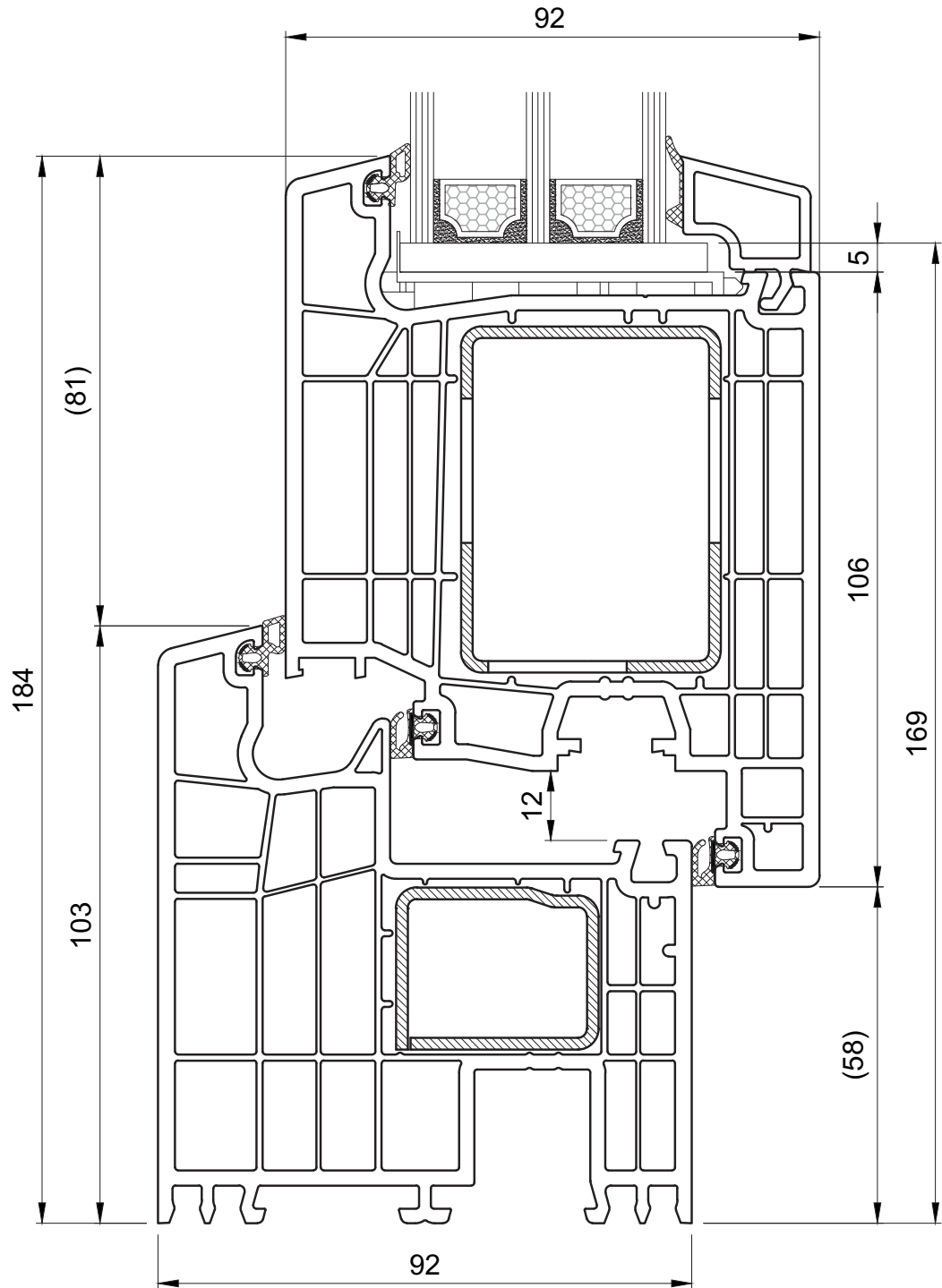

Drzwi wejściowe, otwierane do wewnątrz



Porte d'entrée, ouverture vers l'intérieur



Deur, naar binnen opendraaiend



Eingangstür, nach Innen öffnend



Porta d'ingresso, l'apertura verso interno





BluEvolution 92 **bE**

170 430 - 371 040

**OKO
OKNA**

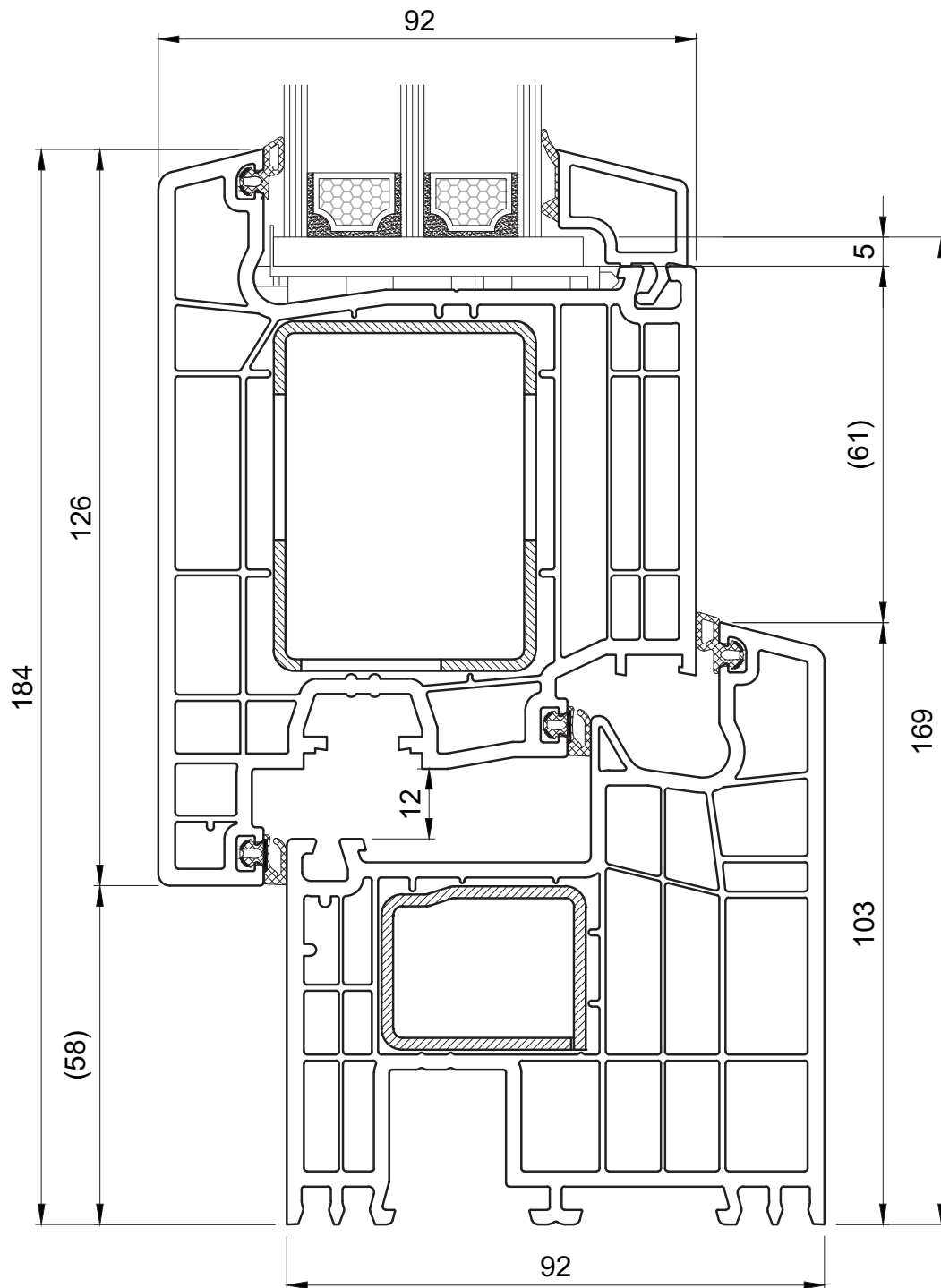

Drzwi wejściowe, otwierane na zewnątrz

Porte d'entrée, ouverture vers l'extérieur





Deur, naar buiten opendraaiend

Eingangstür, nach Aussen öffnend

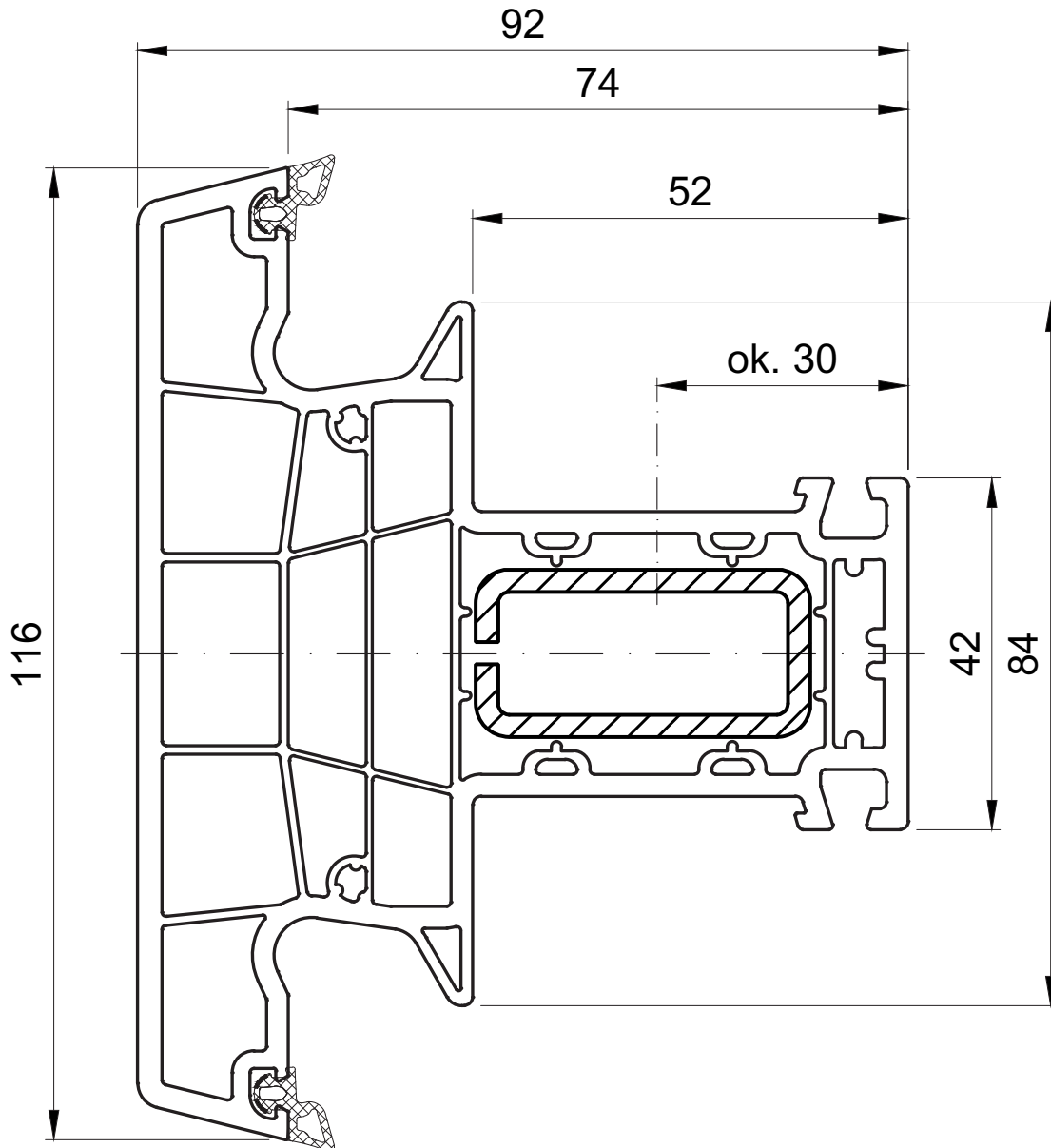
Porta d'ingresso, l'apertura verso esterno





-  Słupek stały 116 mm (stosowany tylko do ramy)
-  Meneau fixe 116 mm (utilise seulement pour dromant)
-  Vaste stijl 116 mm (gebruikt alleen in de kader)
-  Querkämpfer 116 mm (nur für Rahmen bestimmt)
-  Montante fisso 116 mm (usato solo nel telaio)



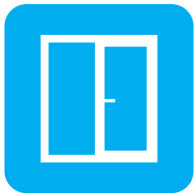

BluEvolution 92 **bE**

171 020 - 172 420 - 171 020

**OKO
OKNA**

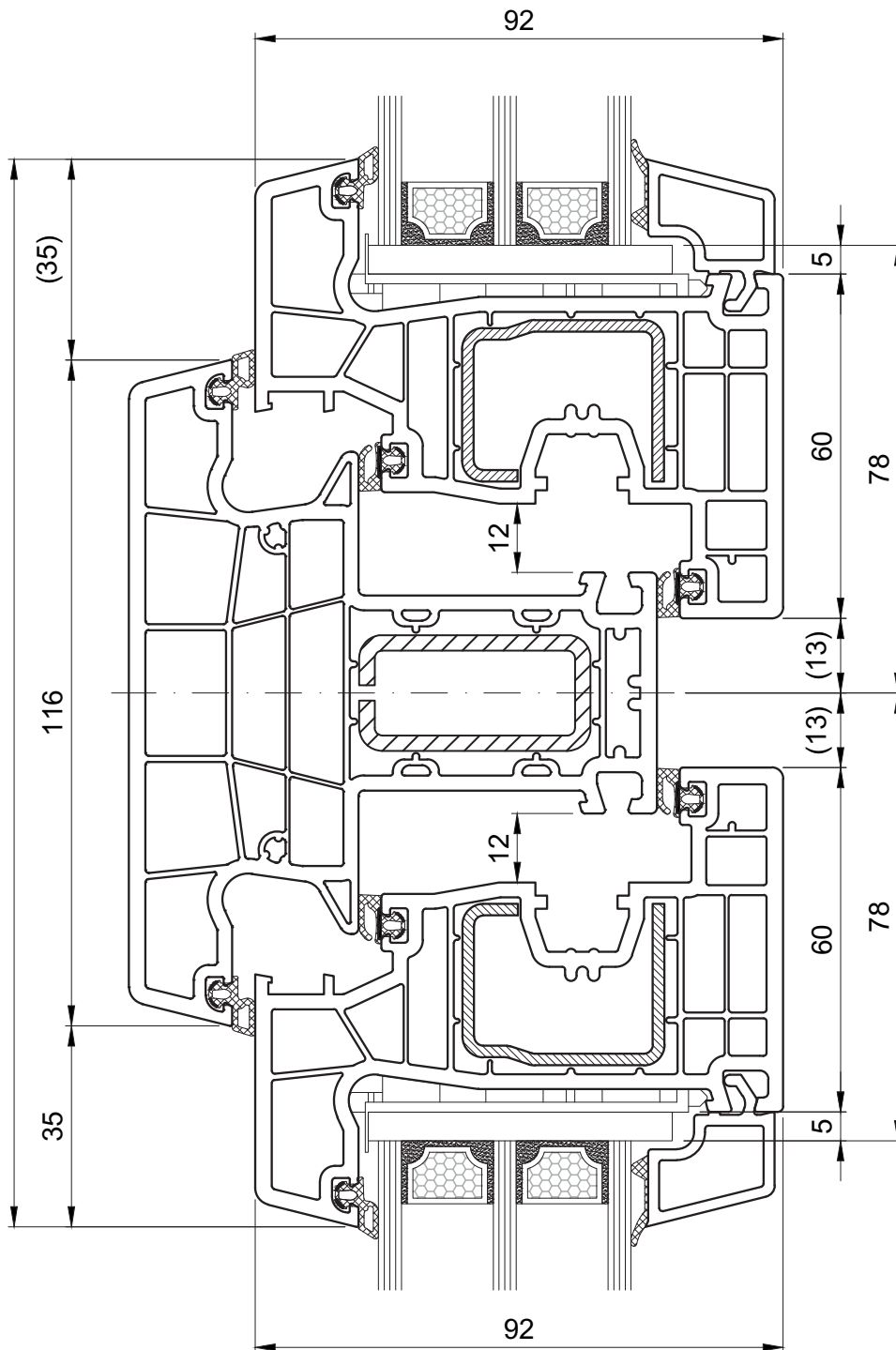

Słupek stały z dwoma skrzydłami okiennymi Classic-line

Coupe de deux ouvrants de fenêtre Classic-line, meneau fixe

Aansluiting van twee raam vleugels Classic-line met vaste stijl

Zwei Fensterflügel Classic-line, verbunden mit Hilfe eines Stulps

Guinzione di due ante finestra Classic-line con montante fisso



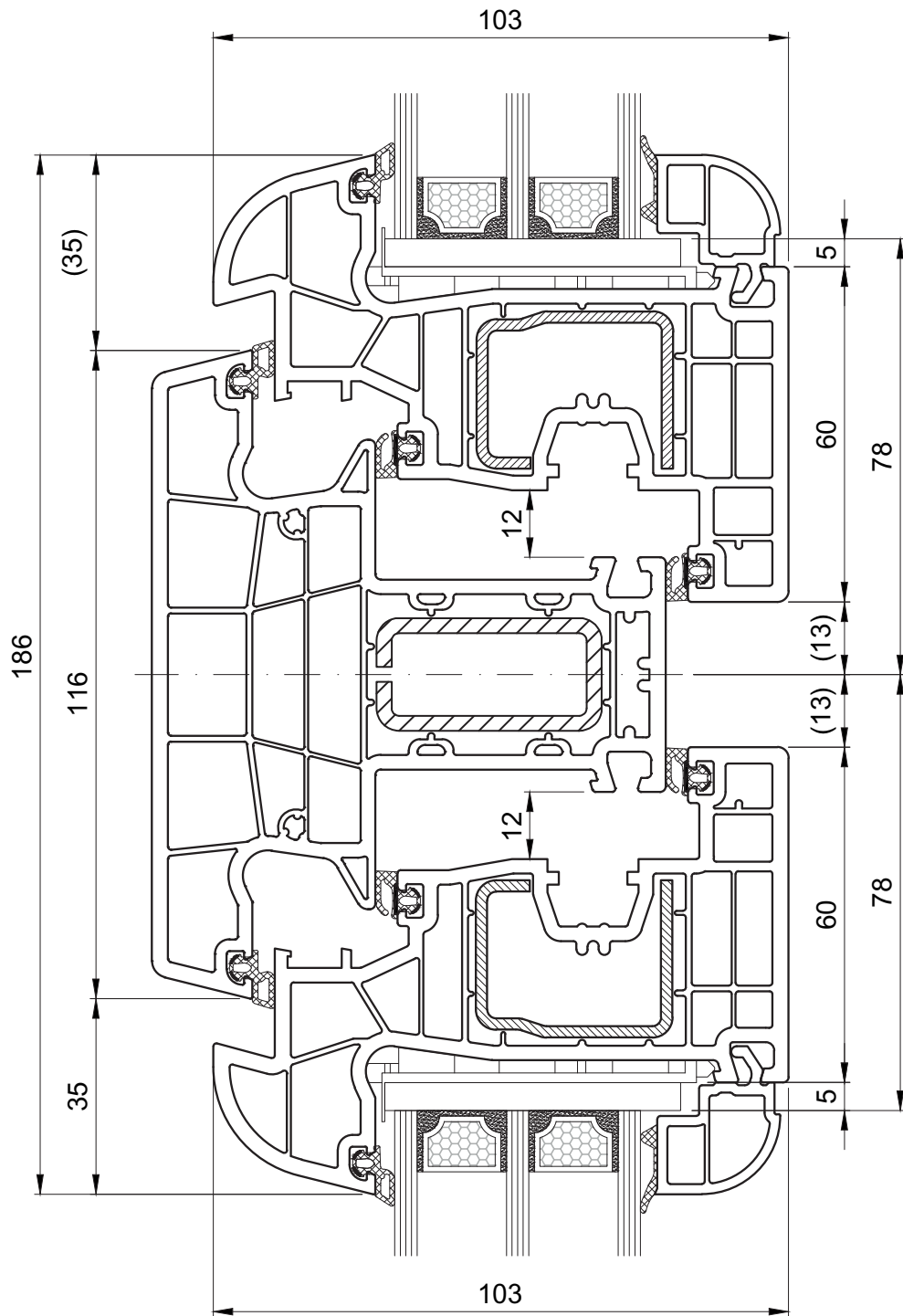

Słupek stały z dwoma skrzydłami okiennymi Round-line



Coupe de deux ouvrants de fenêtre Round-line, meneau fixe



Aansluiting van twee raam vleugels Round-line met vaste stijl



Zwei Fensterflügel Round-line, verbunden mit Hilfe eines Stulps



Guinzione di due ante finestra Round-line con montante fisso





BluEvolution 92 **bE**

171 030 - 176 020 - 171 030

**OKO
OKNA**

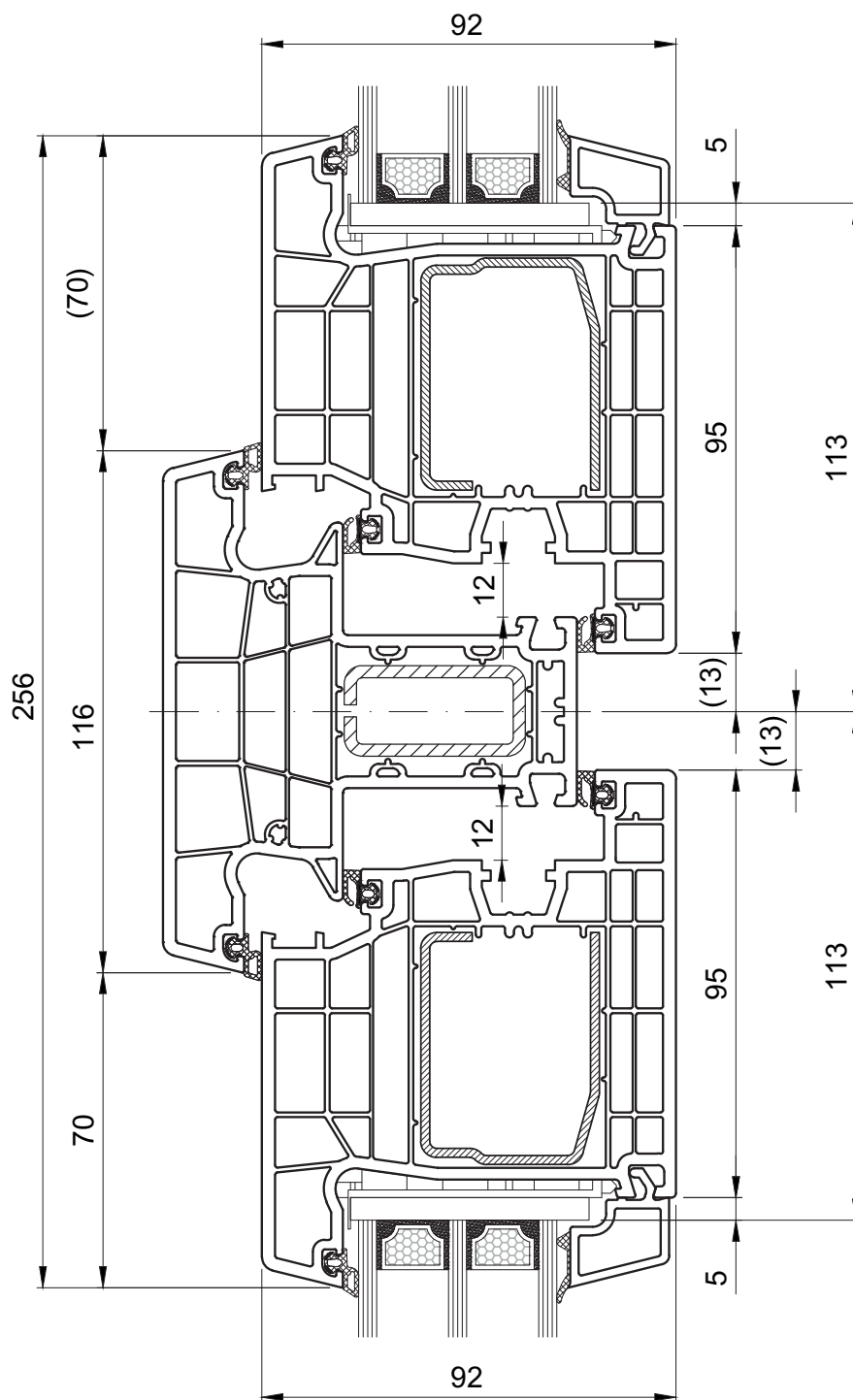

Słupek stały z dwoma skrzydłami tarasowymi Classic-line, otwierane do wewnątrz

Coupe de deux porte de passage Classic-line, meneau fixe, ouverture vers l'intérieur

Aansluiting van twee terras profiel Classic-line, naar binnen opendraaiend met vaste stijl

Zwei Terrassentür Classic-line, nach Innen öffnend, Stulp

Giunzione di due portaveranda Classic-line con montane fisso, l'apertura verso interno



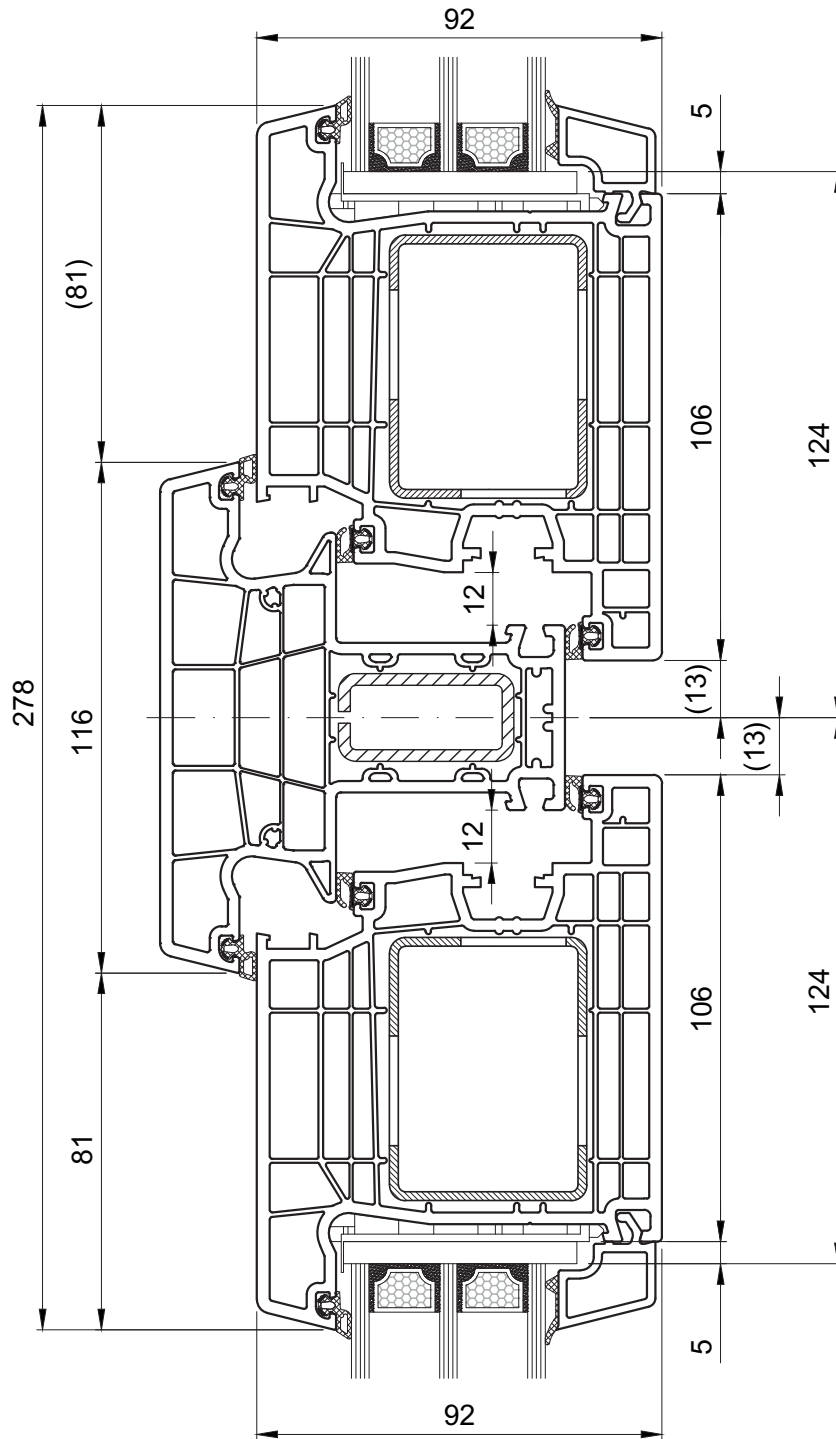
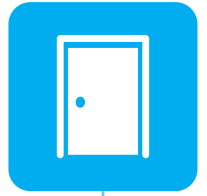

Słupek stały z dwoma skrzydłami drzwiowymi Classic-line, otwierane do wewnątrz



Coupe de deux ouvrants de porte Classic-line, meneau fixe, ouverture vers l'intérieur



Aansluiting van twee deur vleugels Classic-line naar binnen opendraaiend met vaste stijl



Zwei Türflügel Classic-line, Stulp, nach Innen öffnend



Giunzione di due ante della porta Classic-line con montane fisso, l'apertura verso interno





BluEvolution 92 **bE**

371 040 - 172 420 - 371 040

**OKO
OKNA**

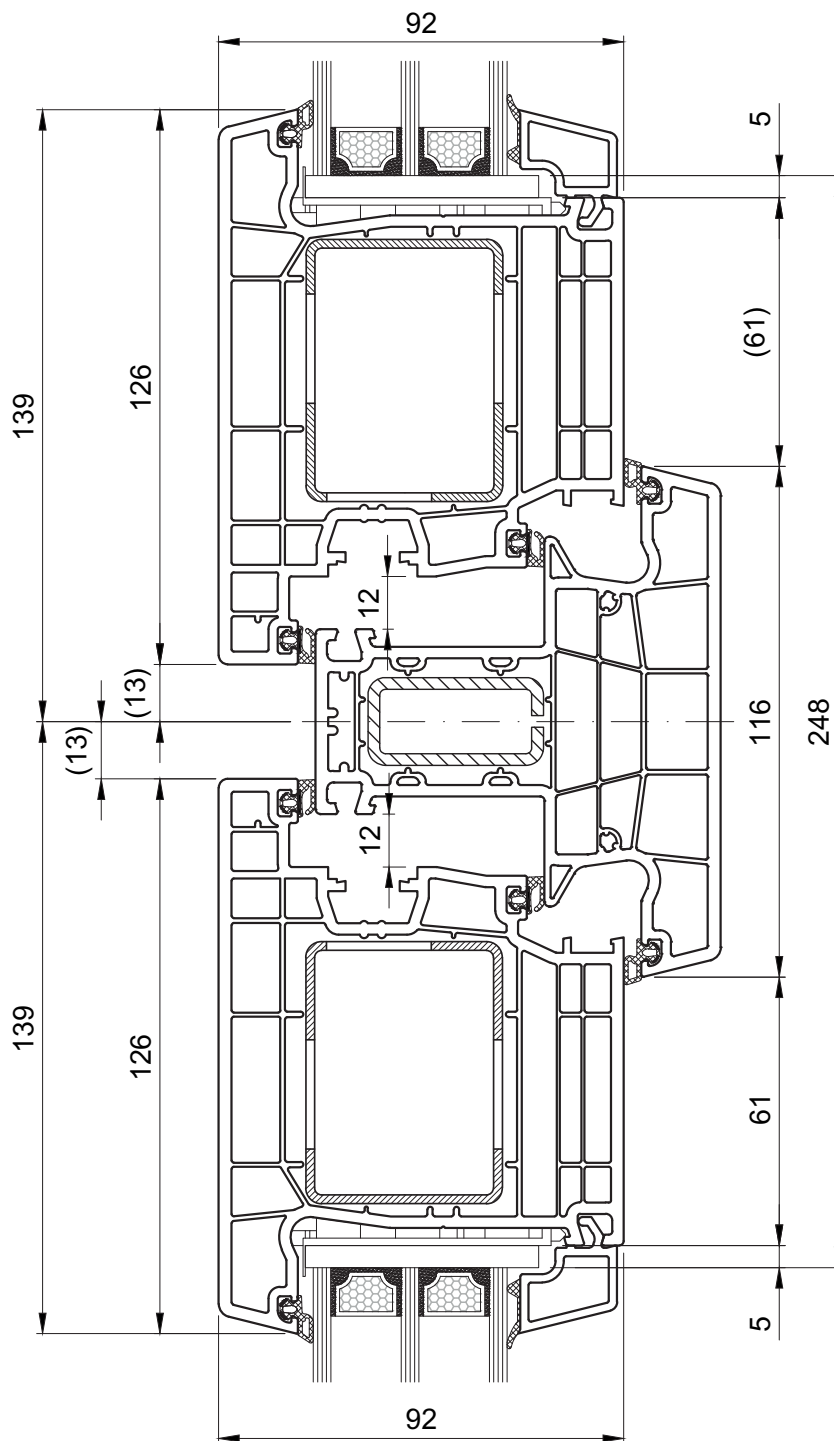

Słupek stały z dwoma skrzydłami drzwiowymi Classic-line, otwierane na zewnątrz

Coupe de deux ouvrants de porte Classic-line, meneau fixe, ouverture vers l'extérieur

Aansluiting van twee deur vleugels Classic-line naar buiten opendraaiend met vaste stijl

Zwei Türflügel Classic-line, Stulp, nach Aussen öffnend

Giunzione di due ante della porta Classic-line con montane fisso, l'apertura verso esterno



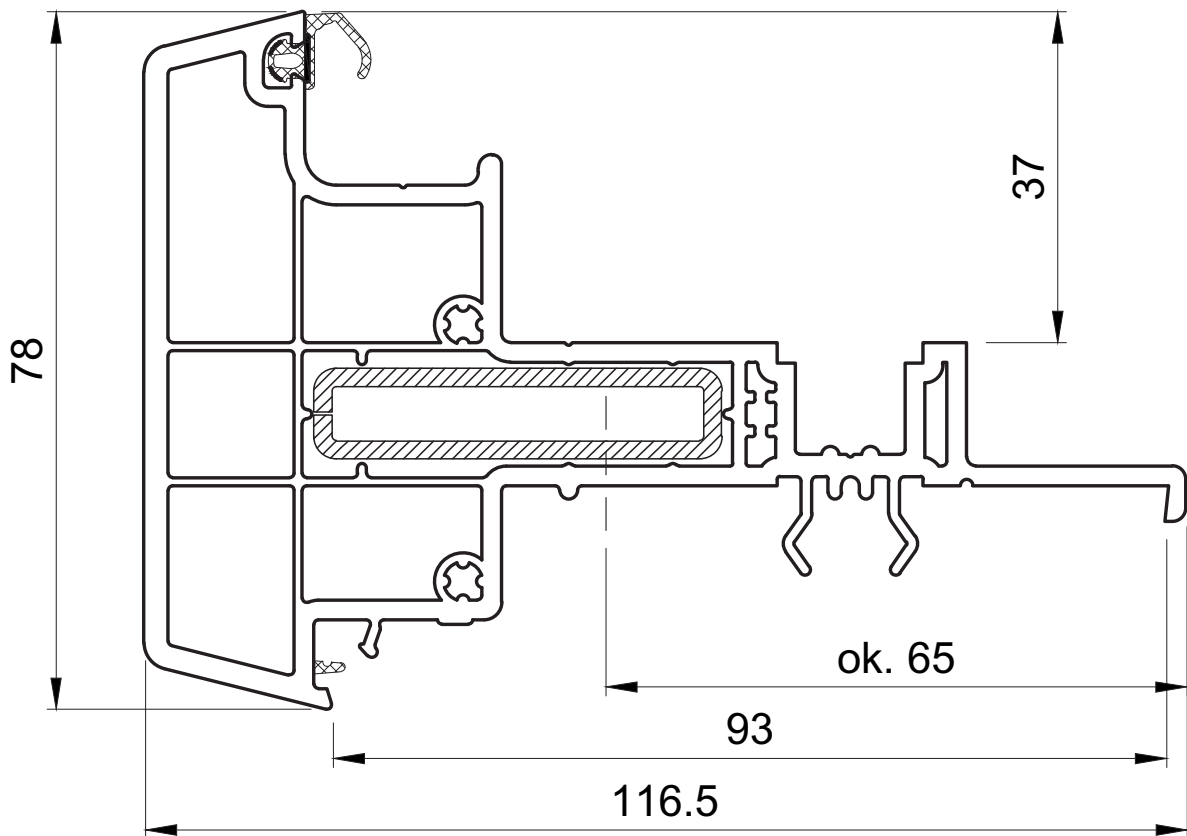

-  Słupek ruchomy 78 mm (wąski)
-  Meneau mobile 78 mm
-  Mobile paal (stulp) 78 mm
-  Stulp 78 mm
-  Montante mobile 78 mm



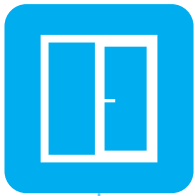

BluEvolution 92 **bE**

171 020 - 176 020 - 171 020

**OKO
OKNA**

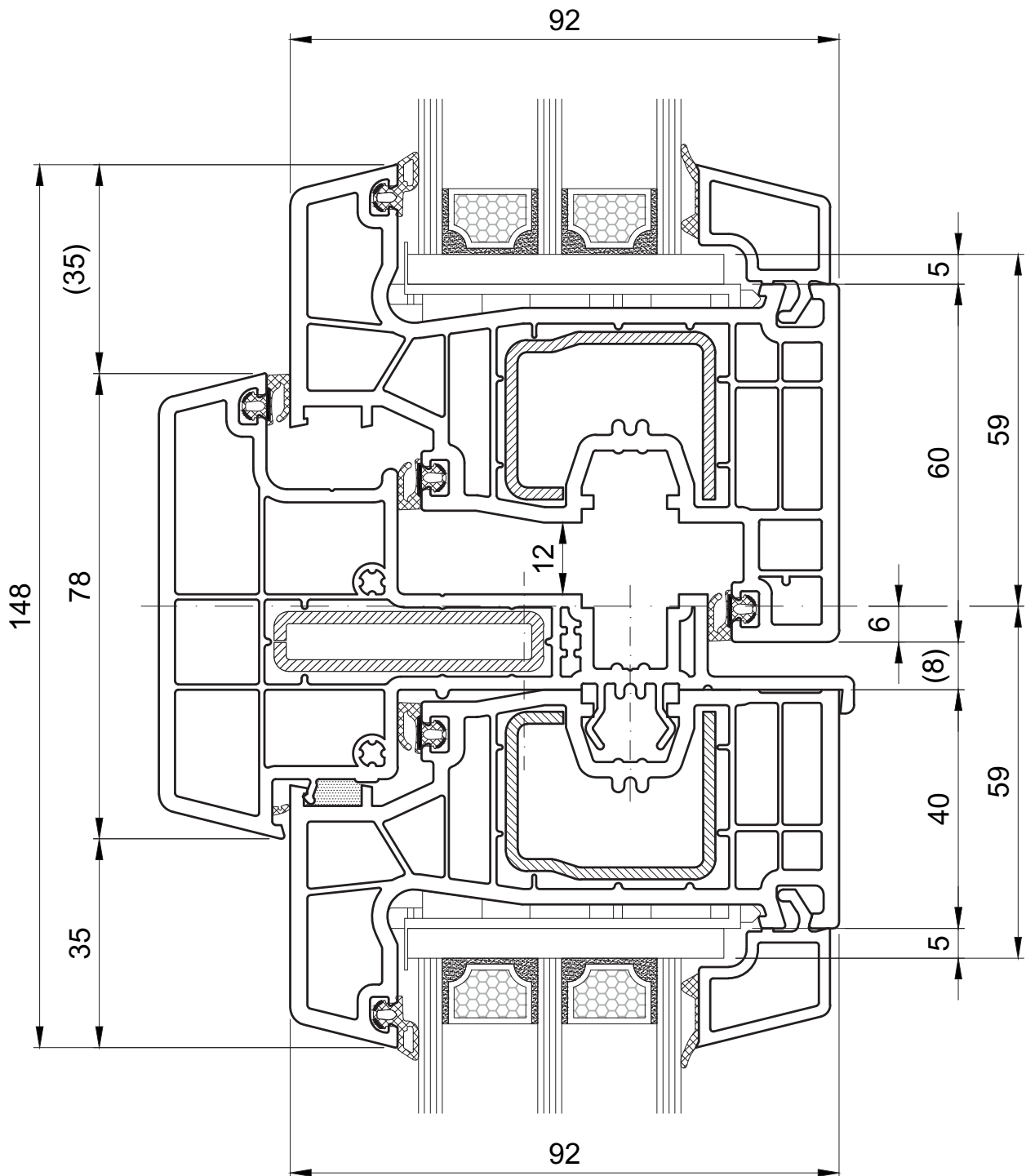

Słupek ruchomy 78 mm z dwoma skrzydłami okiennymi Classic-line

Coupe de deux ouvrants de fenêtre Classic-line, meneau mobile 78 mm





Aansluiting van twee raam vleugels Classic-line met stulp 78 mm

Zwei Fensterflügel Classic-line, verbunden mit Hilfe eines Stulps 78 mm

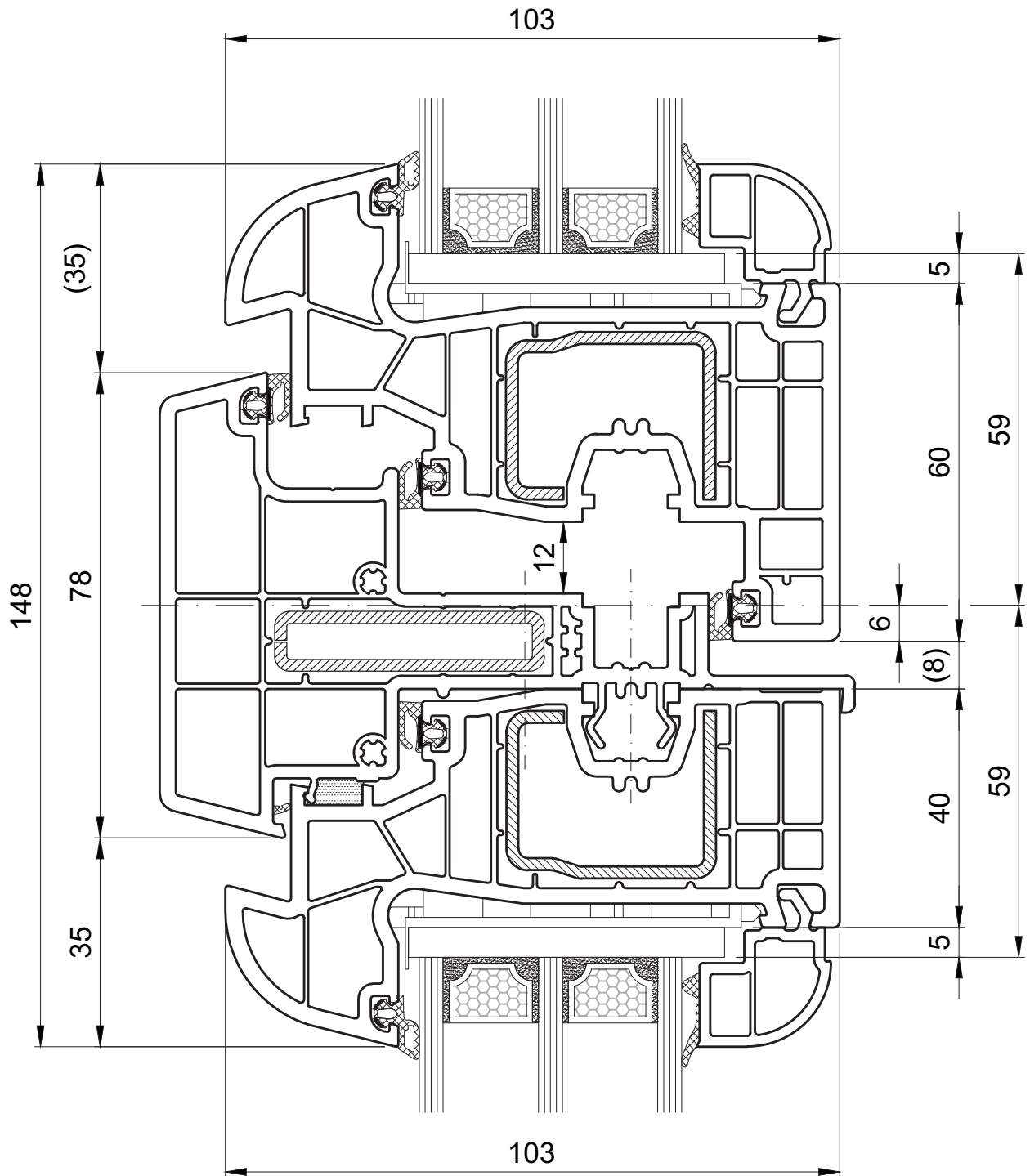
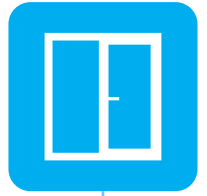
Guinzione di due ante finestra Classic-line con montante mobile 78 mm





-  Słupek ruchomy 78 mm z dwoma skrzydłami okiennymi Round-line
-  Coupe de deux ouvrants de fenêtre Round-line, meneau mobile 78 mm
-  Aansluiting van twee raam vleugels Round-line met stulp 78 mm
-  Zwei Fensterflügel Round-line, verbunden mit Hilfe eines Stulps 78 mm
-  Guinzione di due ante finestra Round-line con montante mobile 78 mm





BluEvolution 92 **bE**

171 030 - 176 020 - 171 030

**OKO
OKNA**

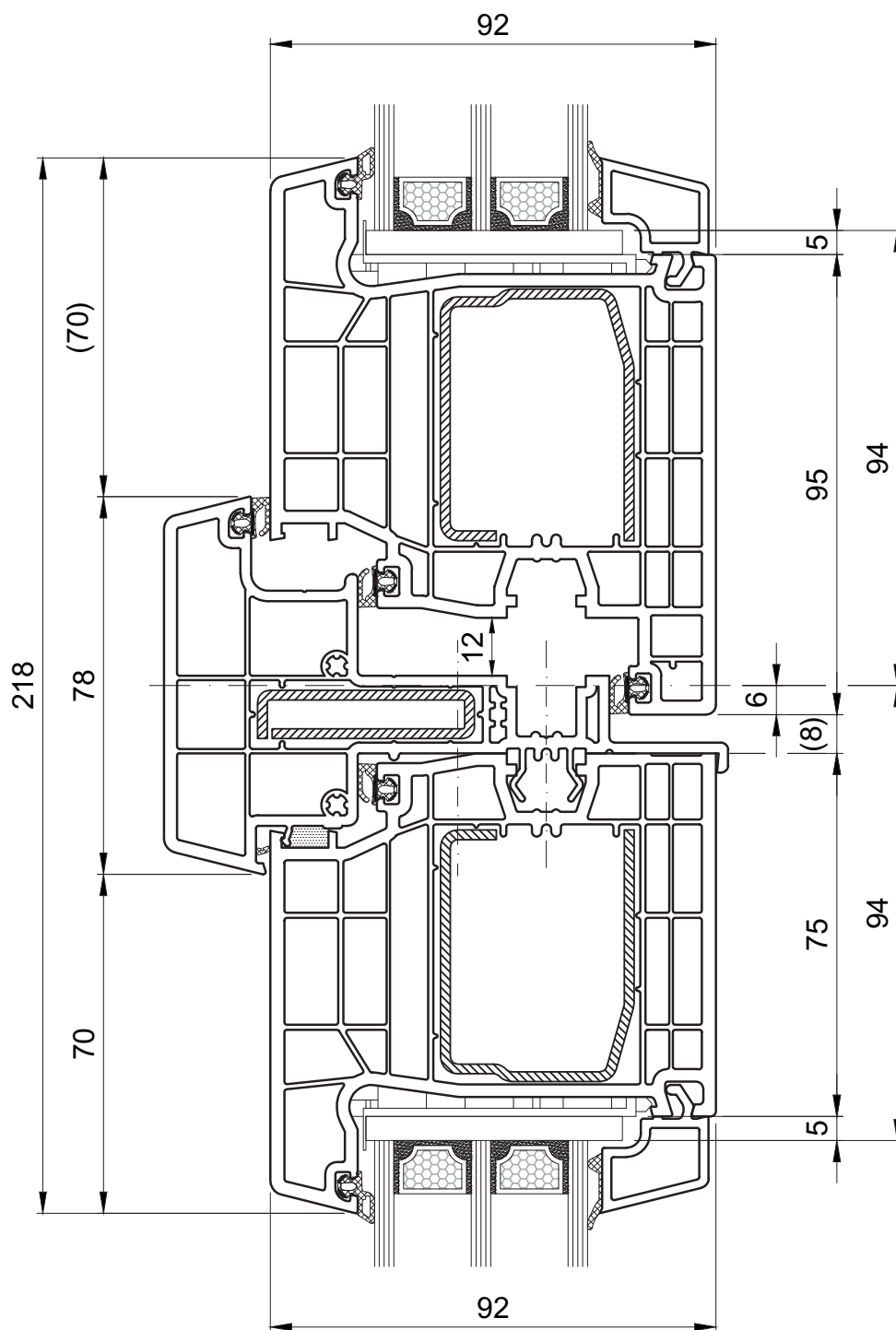

Słupek ruchomy 78 mm z dwoma skrzydłami tarasowymi Classic-line, otwierane do wewnątrz

Coupe de deux porte de passage Classic-line, meneau mobile 78 mm, ouverture vers l'intérieur

Aansluiting van twee terras profiel Classic-line naar binnen opendraaiend met stulp 78 mm

Zwei Terrassentür Classic-line nach Innen öffnend, Stulp 78 mm

Giunzione di due portaveranda Classic-line con montane mobile 78 mm, l'apertura verso interno



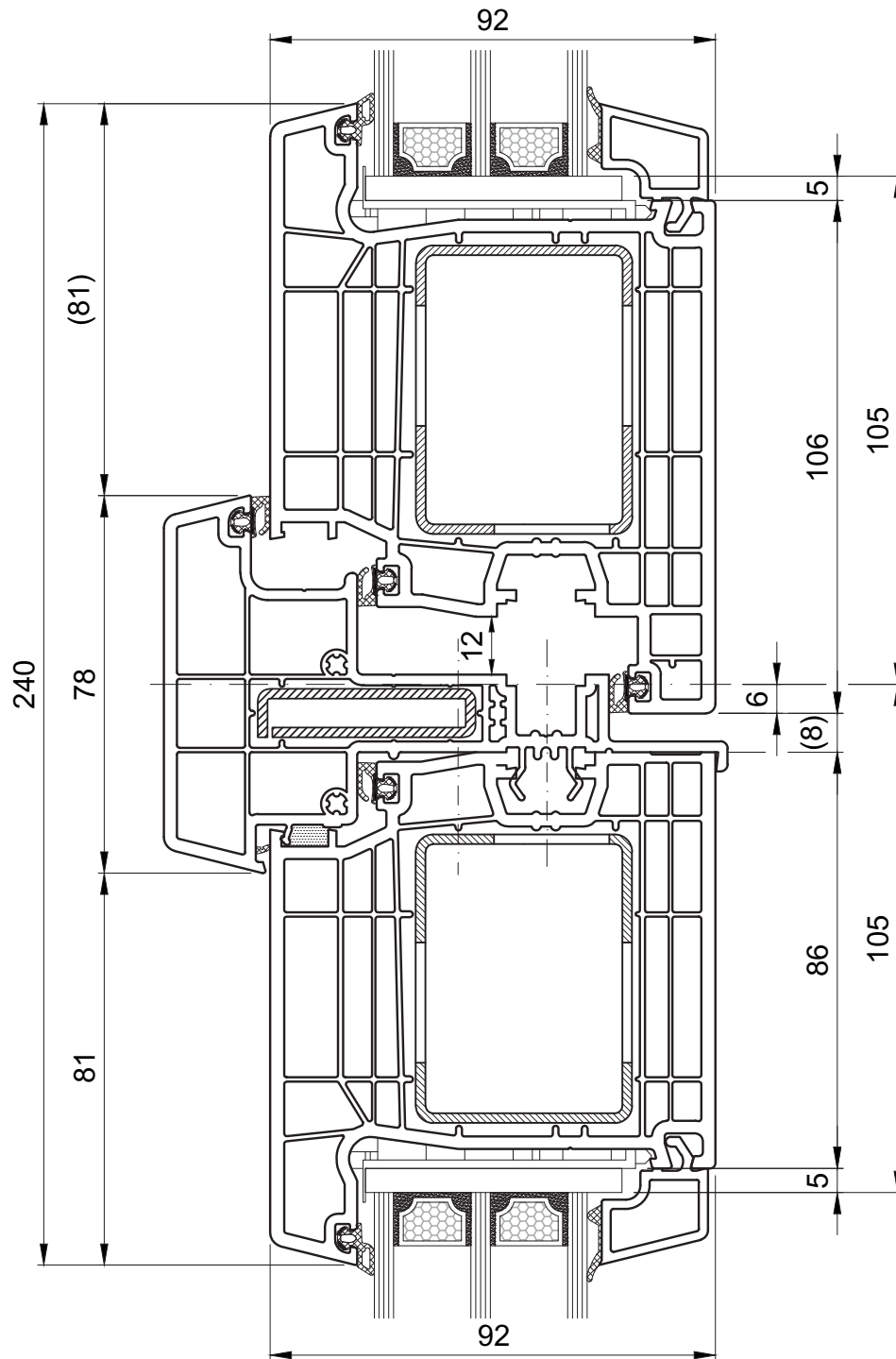

Słupek ruchomy 78 mm z dwoma skrzydłami drzwiowymi Classic-line, otwierane do wewnątrz



Coupe de deux ouvrants de porte Classic-line, meneau mobile 78 mm, ouverture vers l'intérieur



Aansluiting van twee deur vleugels Classic-line naar binnen opendraaiend met brede stulp 78 mm



Zwei Türflügel Classic-line, verbunden mit Hilfe eines breiten Stulps 78 mm, nach Innen öffnend



Giunzione di due ante della porta Classic-line con montane largo mobile 78 mm, l'apertura verso interno





BluEvolution 92 **bE**

371 040 - 176 020 - 371 040

**OKO
OKNA**

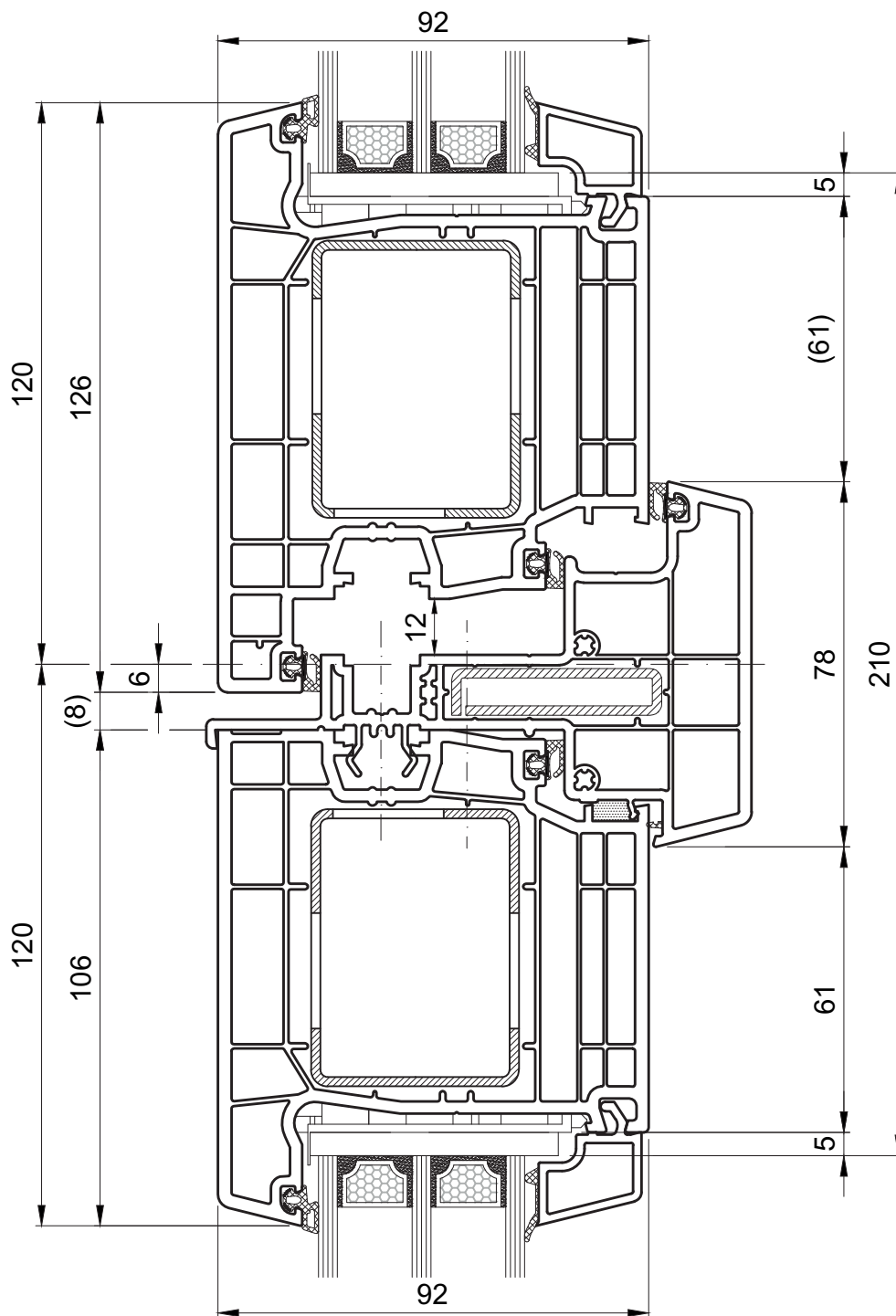

Słupek ruchomy 78 mm z dwoma skrzydłami drzwiowymi Classic-line, otwierane na zewnątrz

Coupe de deux ouvrants de porte Classic-line, meneau mobile 78 mm, ouverture vers l'extérieur

Aansluiting van twee deur vleugels Classic-line naar buiten opendraaiend met brede stulp 78 mm

Zwei Türflügel Classic-line, verbunden mit Hilfe eines breiten Stulps 78 mm, nach Aussen öffnend

Giunzione di due ante della porta Classic-line con montane largo mobile 78 mm, l'apertura verso esterno



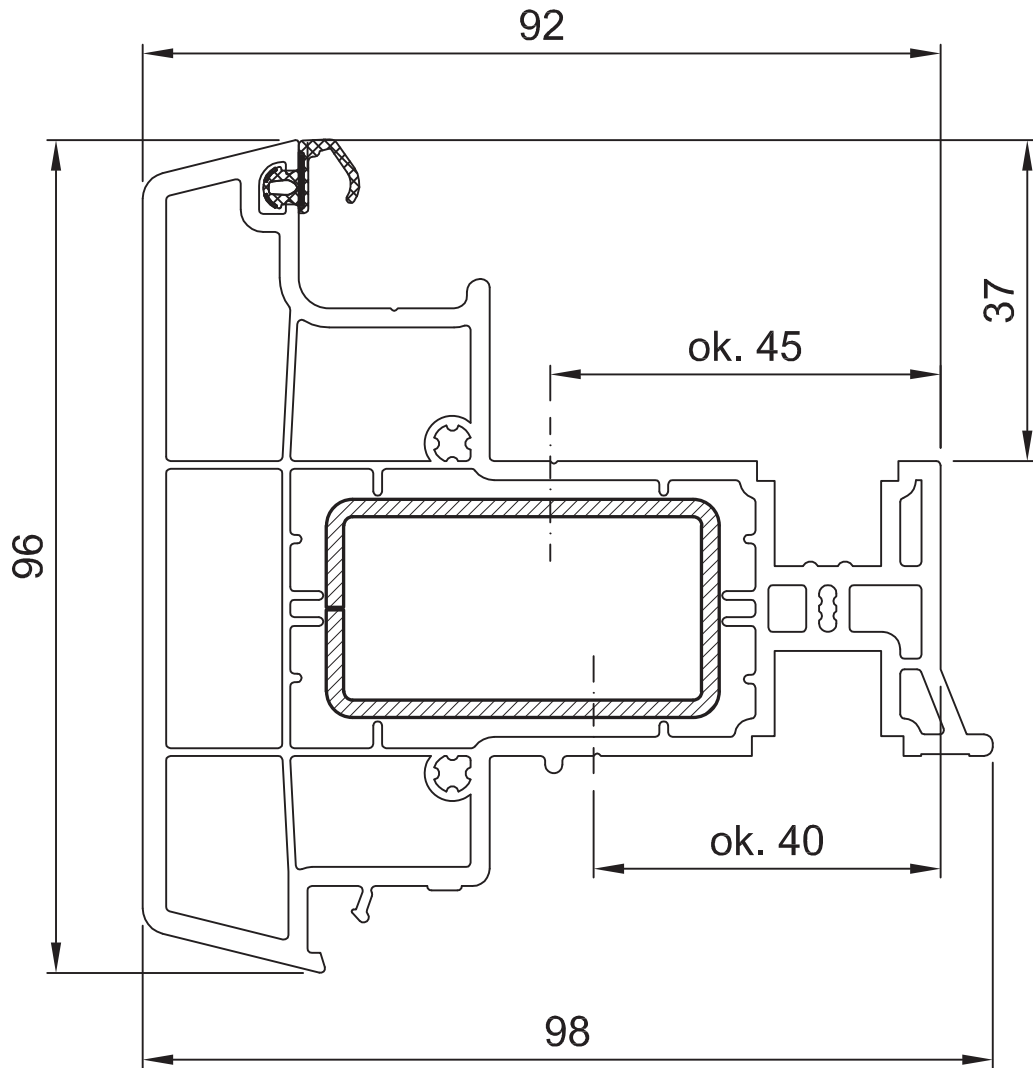

Słupek ruchomy 96 mm (szeroki)



Meneau mobile 96 mm



Brede stulp 96 mm



Breiter Stulp 96 mm



Montante mobile 96 mm



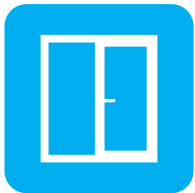

BluEvolution 92 **bE**

171 020 - 176 030 - 171 020

**OKO
OKNA**

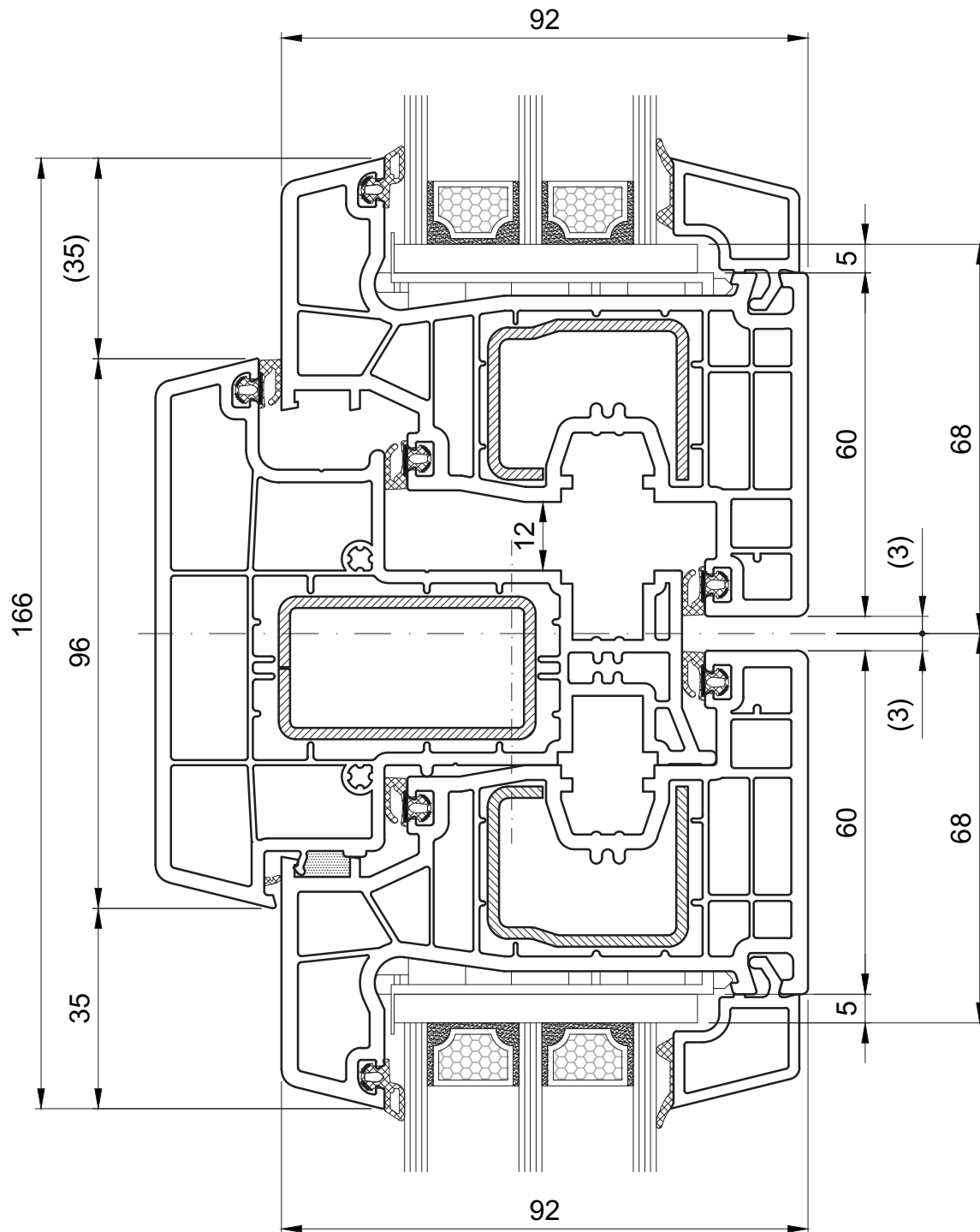

Słupek ruchomy 96 mm z dwoma skrzydłami okiennymi Classic-line

Coupe de deux ouvrants de fenêtre Classic-line, meneau mobile 96 mm

Aansluiting van twee raam vleugels Classic-line met brede stulp

Zwei Fensterflügel Classic-line, verbunden mit Hilfe eines Stulps 96 mm

Giunzione di due ante finestra Classic-line con montante mobile 96 mm



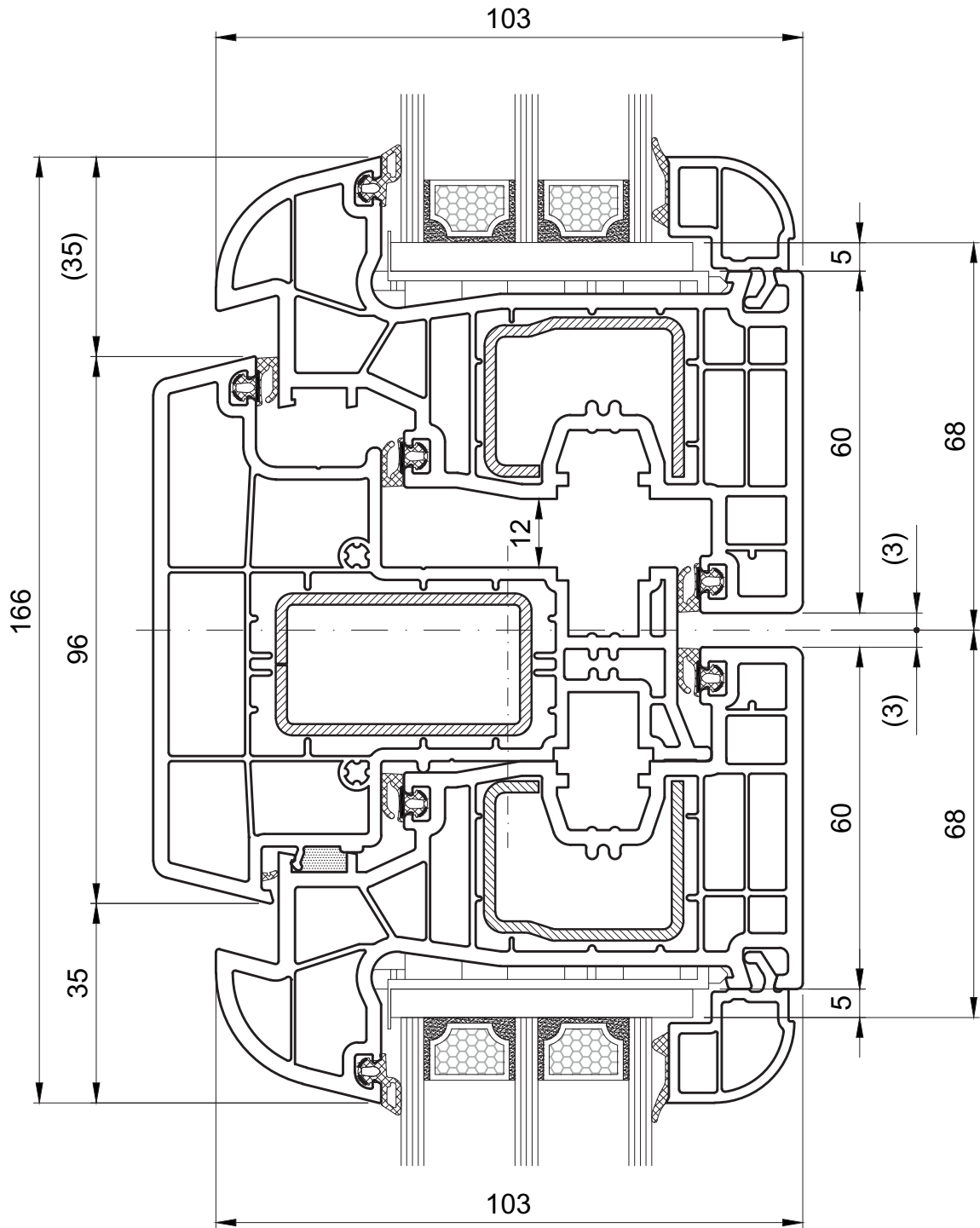

Słupek ruchomy 96 mm z dwoma skrzydłami okiennymi Round-line



Coupe de deux ouvrants de fenêtre Round-line, meneau mobile 96 mm



Aansluiting van twee raam vleugels Round-line met stulp 96 mm



Zwei Fensterflügel Round-line, verbunden mit Hilfe eines Stulps 96 mm



Guinzione di due ante finestra Round-line con montante mobile 96 mm





BluEvolution 92 **bE**

371 040 - 176 030 - 371 040

**OKO
OKNA**

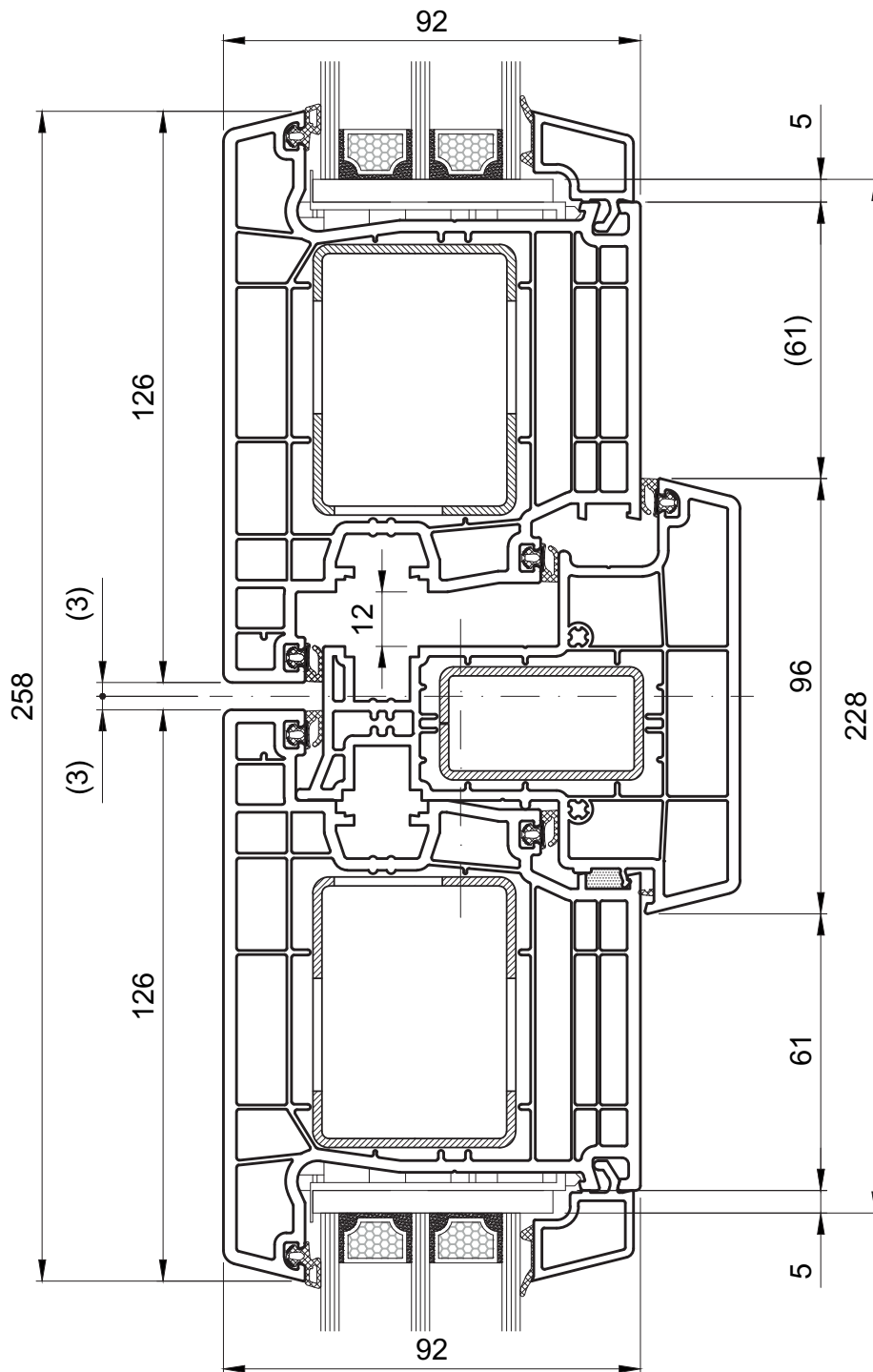

Słupek ruchomy 96 mm z dwoma skrzydłami drzwiowymi Classic-line, otwierane na zewnątrz

Assemblage de deux ouvrants de porte Classic-line, meneau mobile 96 mm, ouverture vers l'extérieur

Aansluiting van twee deur vleugels Classic-line naar buiten opendraaiend met brede stulp 96 mm

Zwei Türflügel Classic-line, verbunden mit Hilfe eines breiten Stulps 96 mm, nach Aussen öffnend

Giunzione di due ante della porta Classic-line con montane largo mobile 96 mm, l'apertura verso esterno



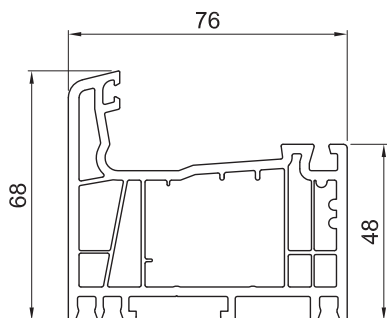
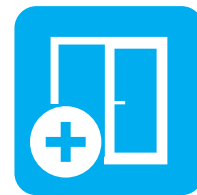

250 221

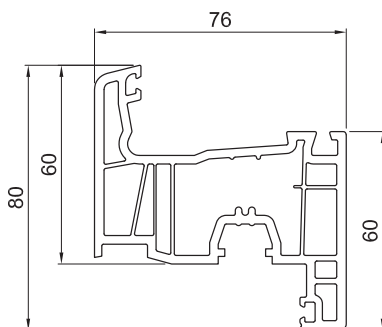

251 021

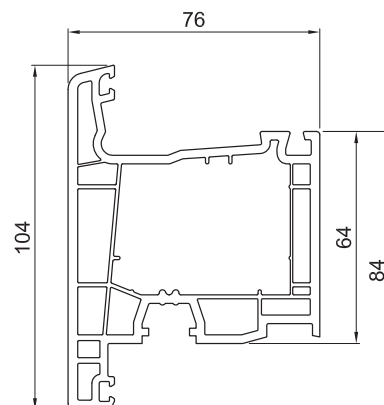

351 030

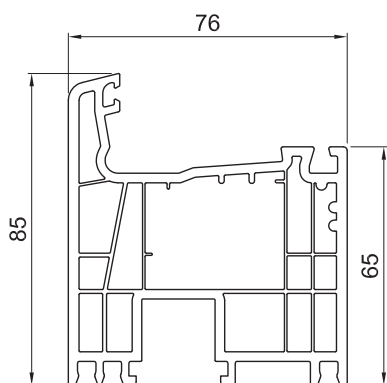

250 234

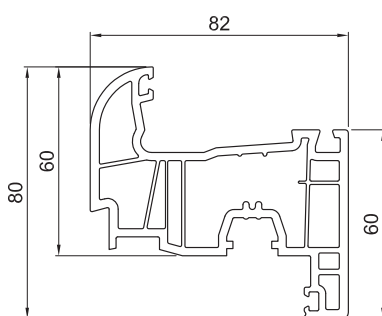

251 221

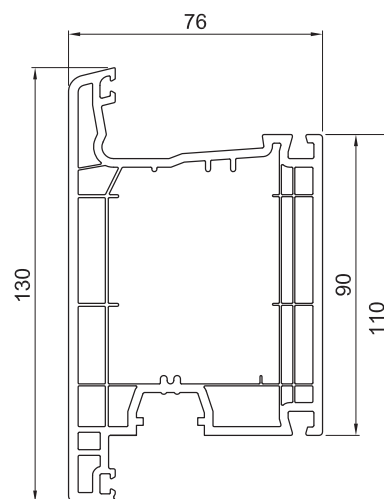

351 040

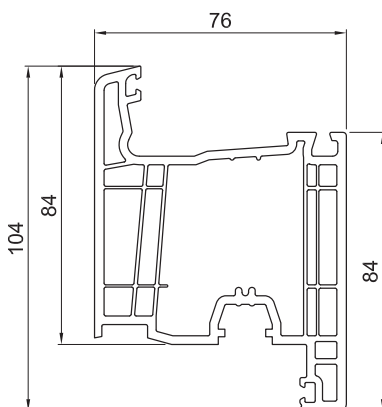

251 030

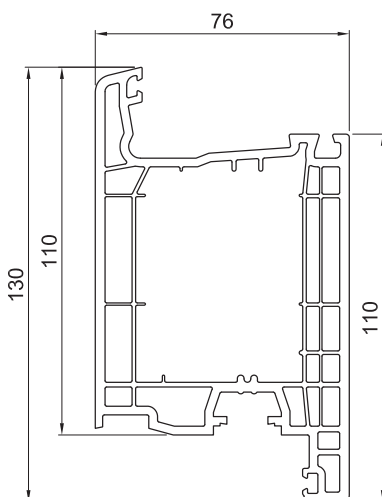

251 040





Streamline 76

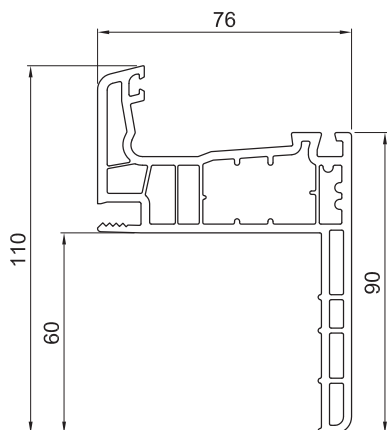

250 100

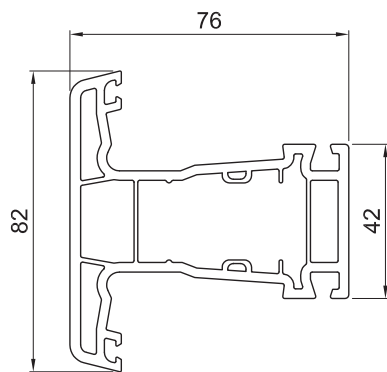

252 120

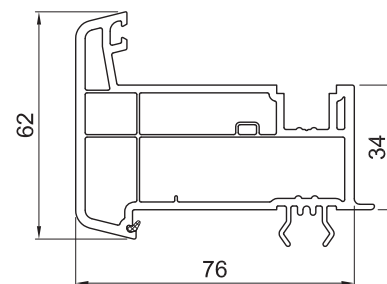

256 030

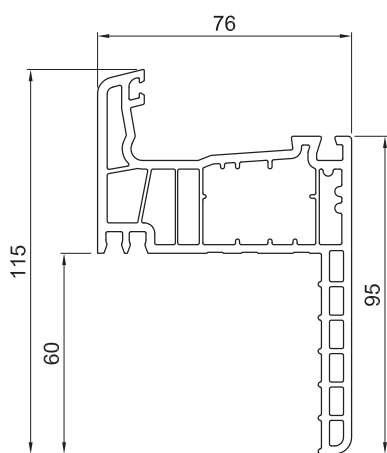

250 148

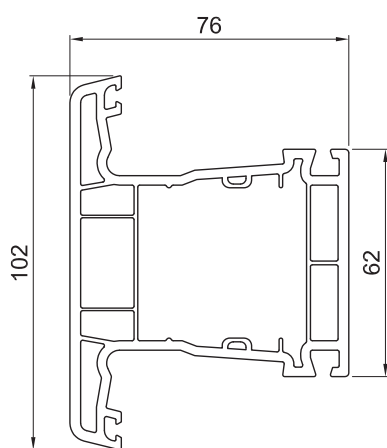

252 130

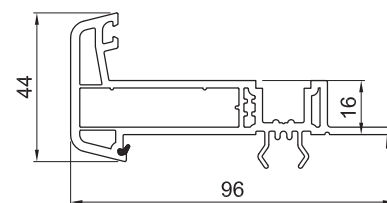

256 020

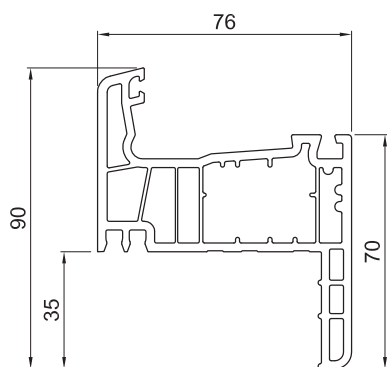

250 154



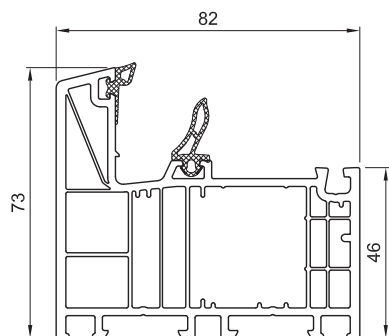
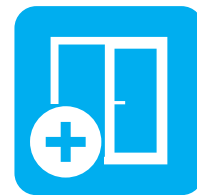

HO9020

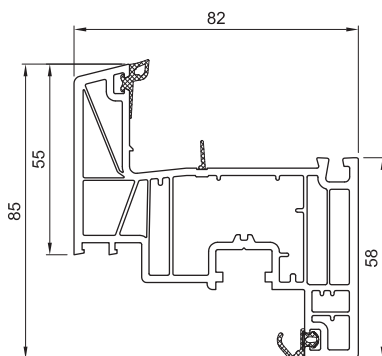

HO8520

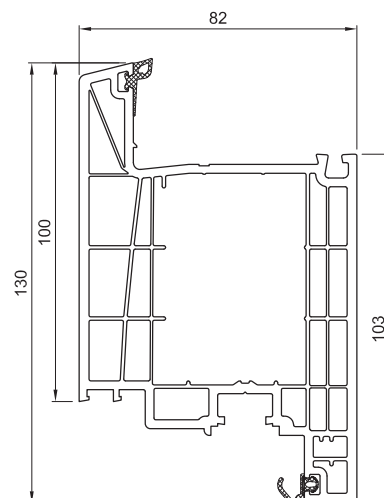

HP8550

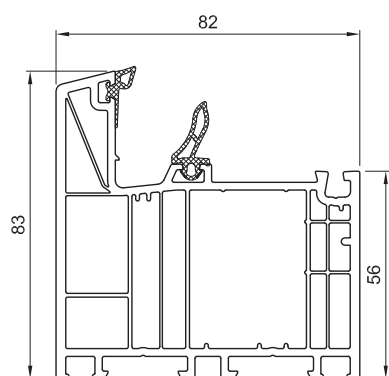

HO9030

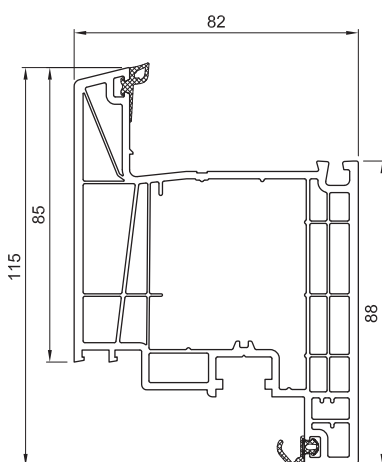

HO8530

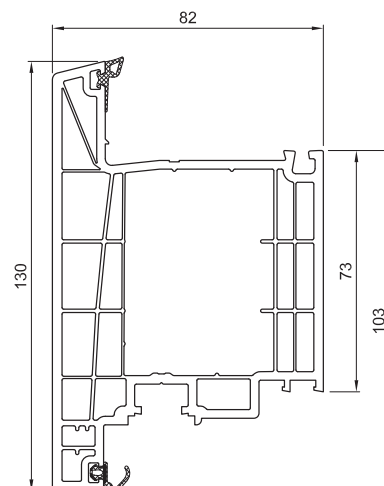

HP8560

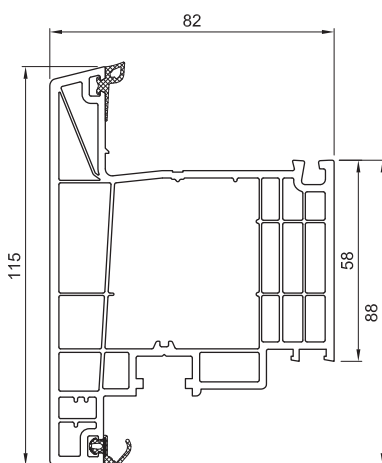

HO8540





BluEvolution 82 **bE**

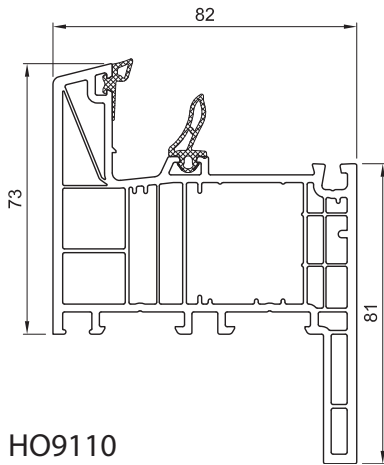

HO9110

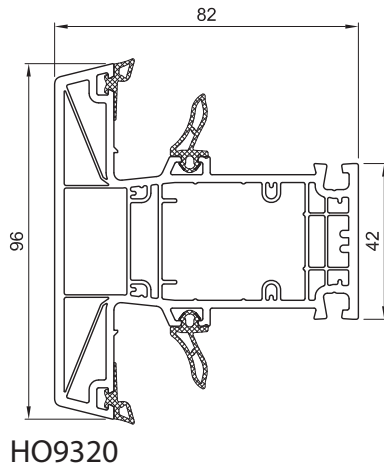

HO9320

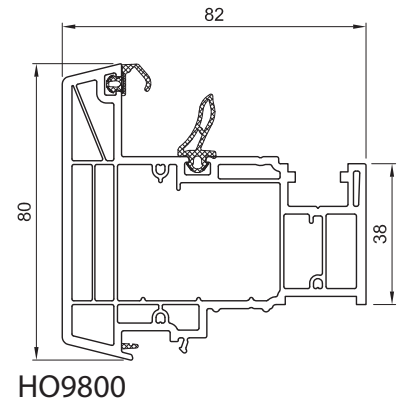

HO9800

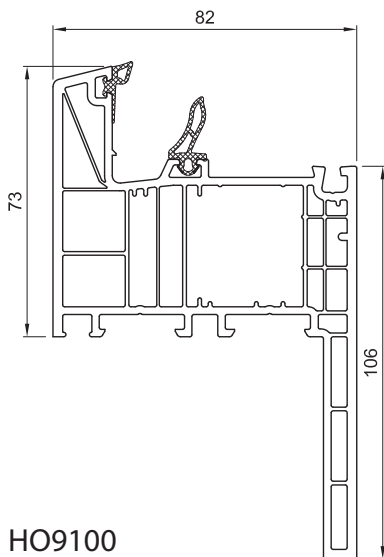

HO9100

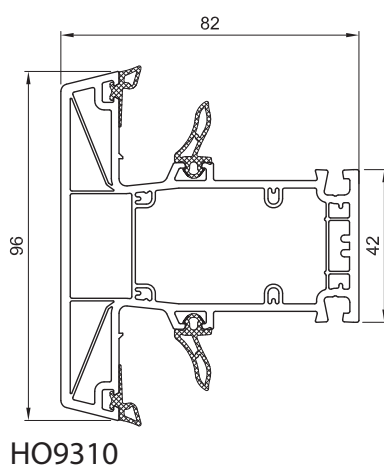

HO9310

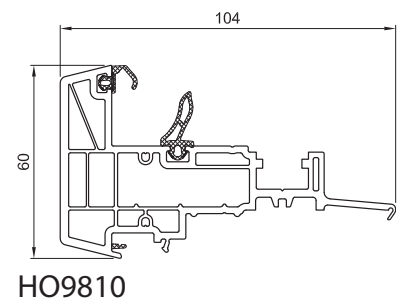

HO9810



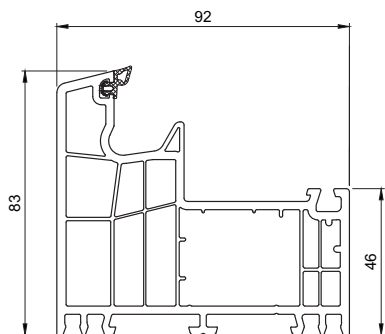
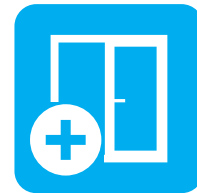

170 820

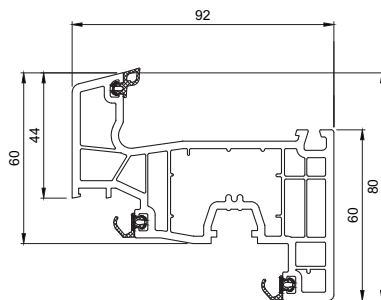

171 020

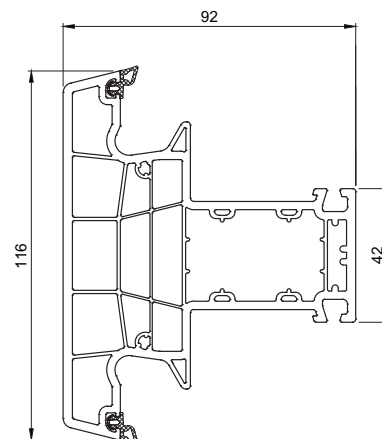

172 420

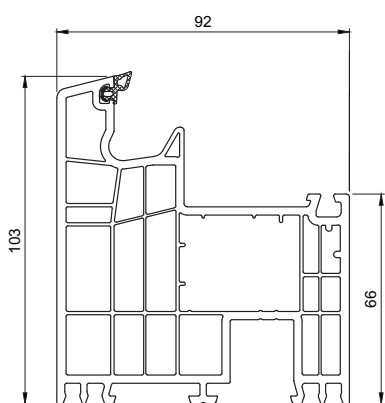

170 430

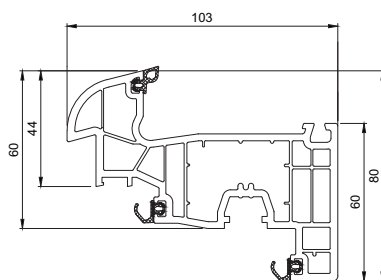

171 226

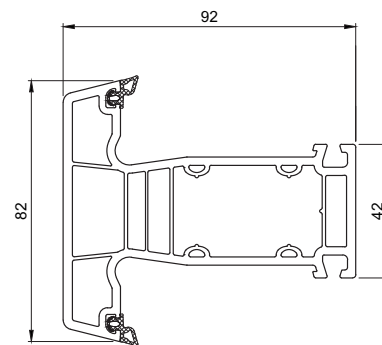

172 425

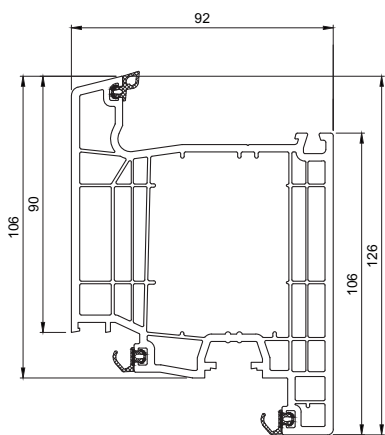

171 040

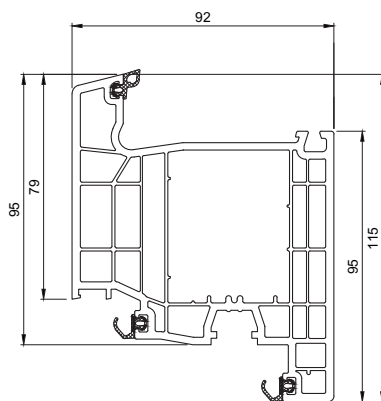

171 030

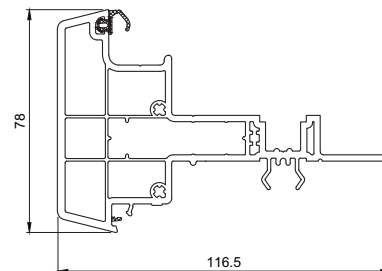

176 020

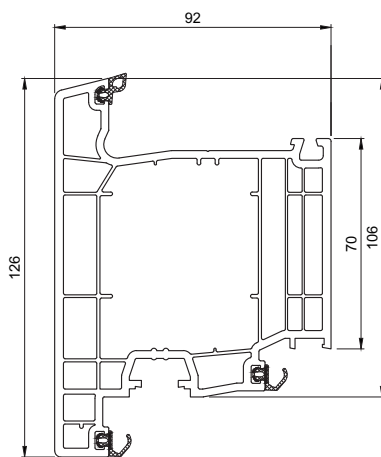

371 040

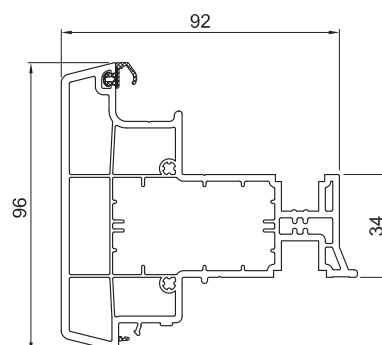

176 030



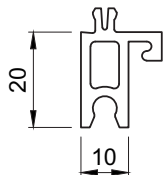

406 105

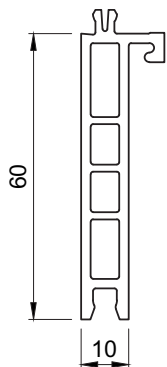

406 157

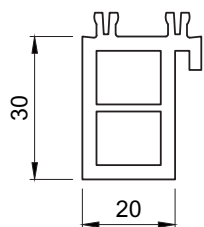

406 139

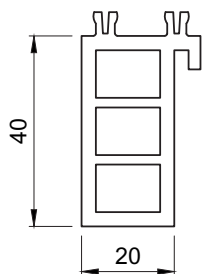

406 140

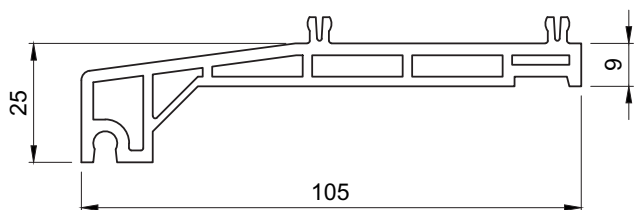

406 115

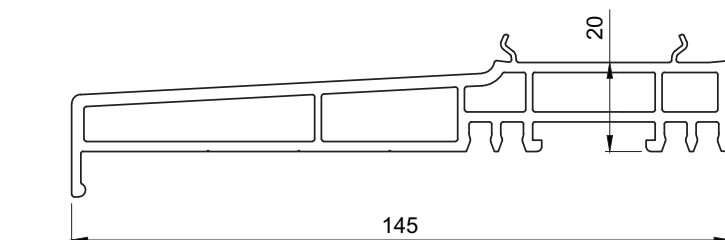

416 110

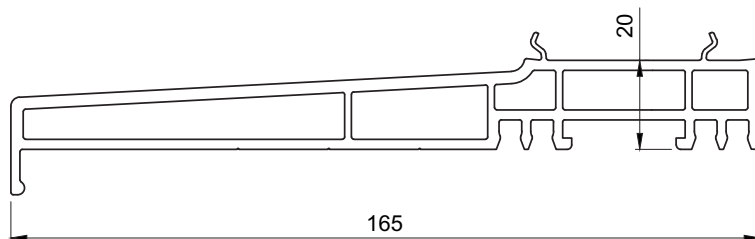

416 115

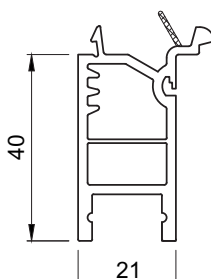

416 142

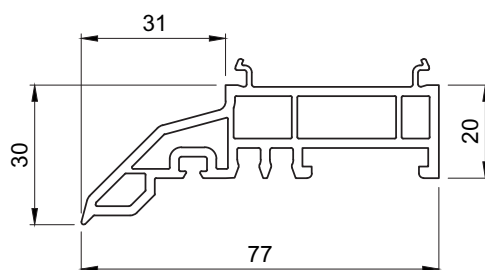

416 126

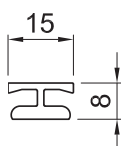

406 255

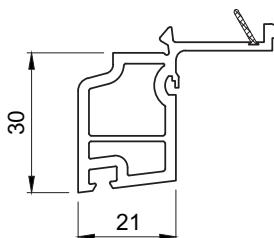

416 133

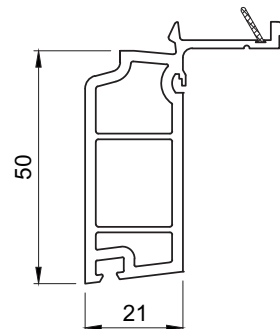

416 135



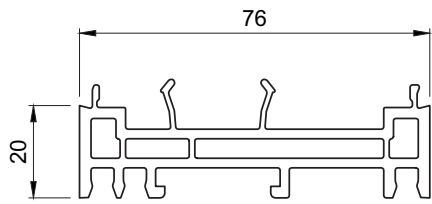

416 160

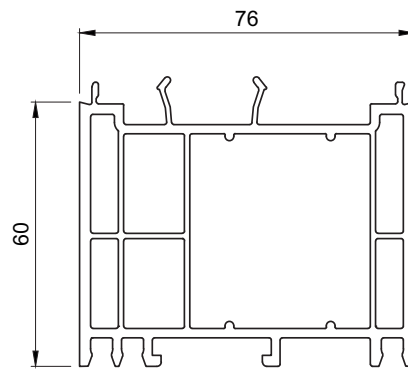

416 170

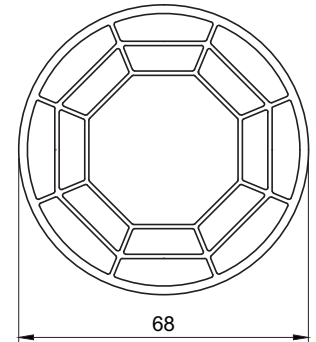

NP0160

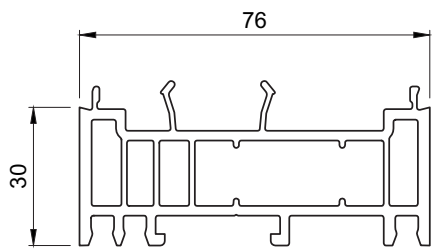

416 163

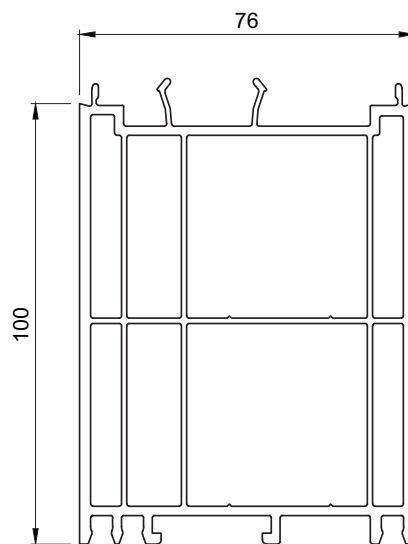

416 176

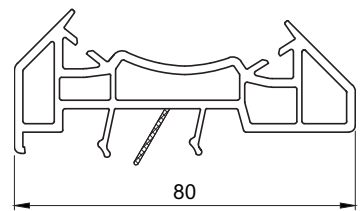

416 251

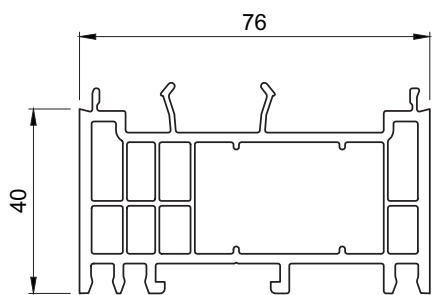

416 164

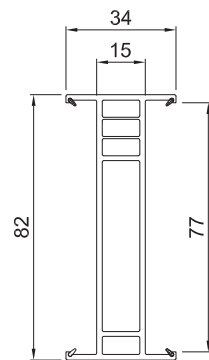

416 273

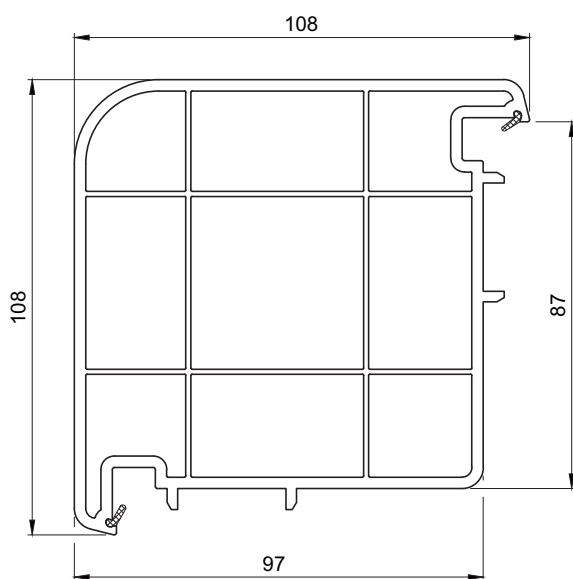

416 210

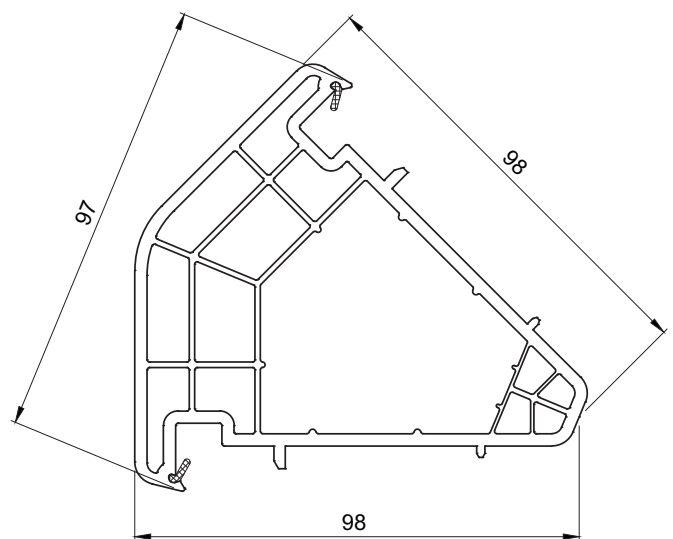

416 240



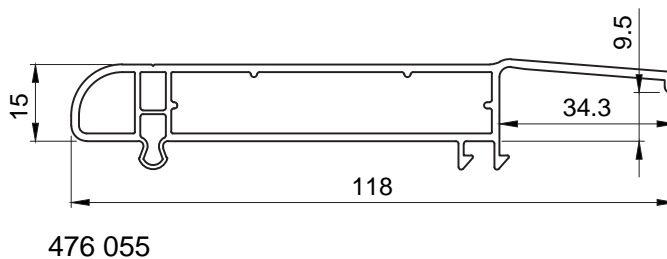
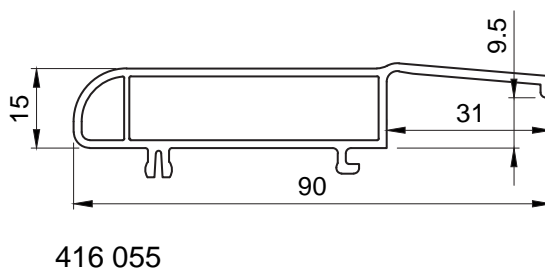
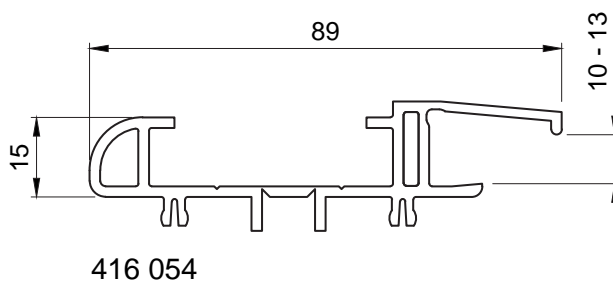
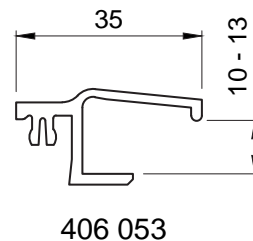
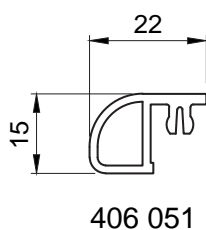
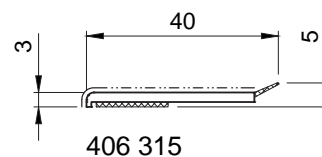
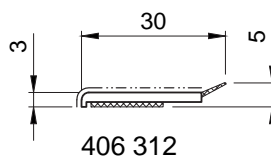
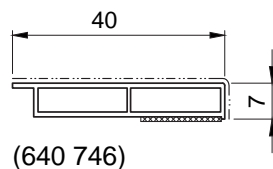
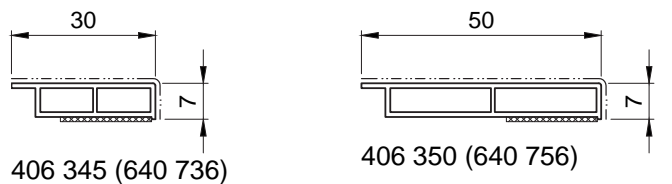
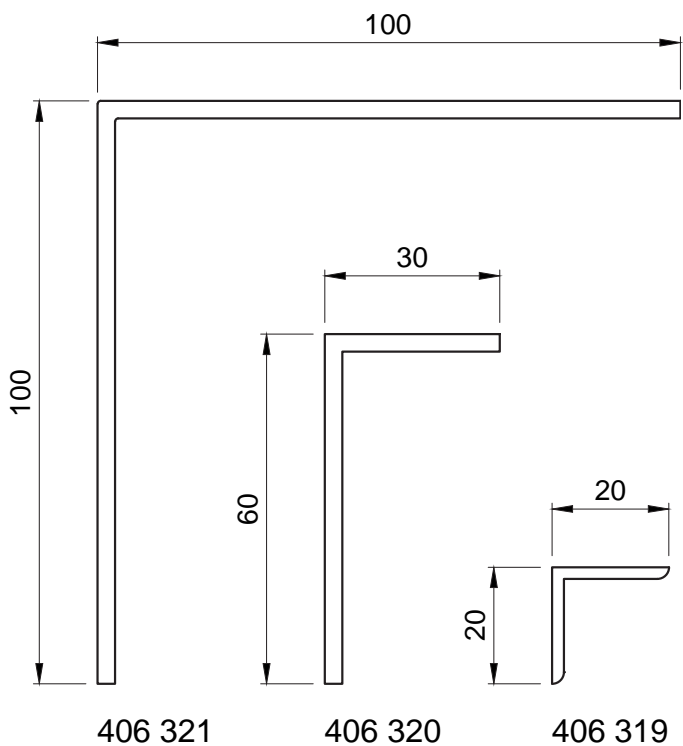
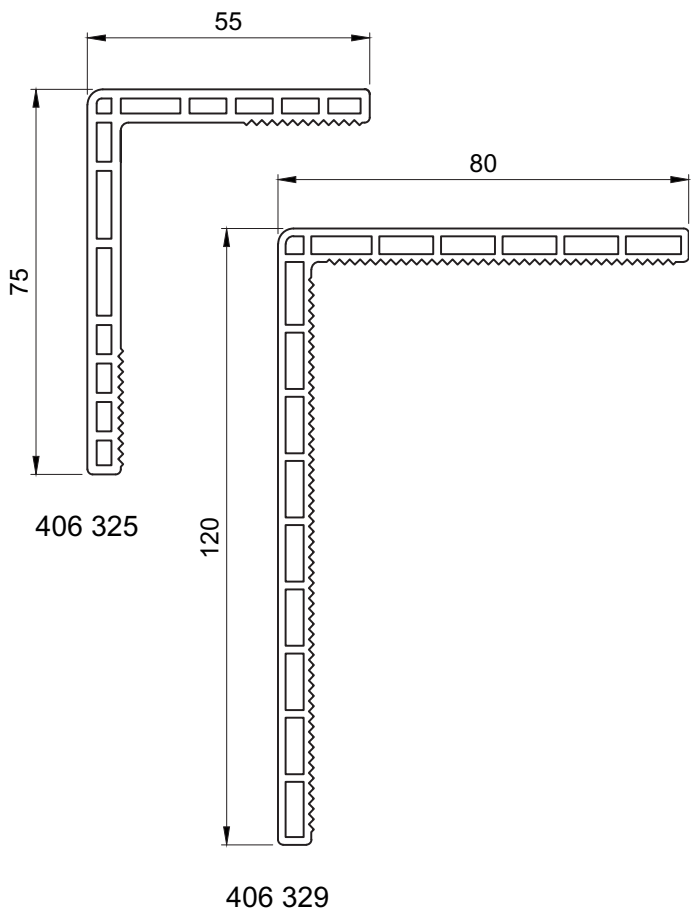

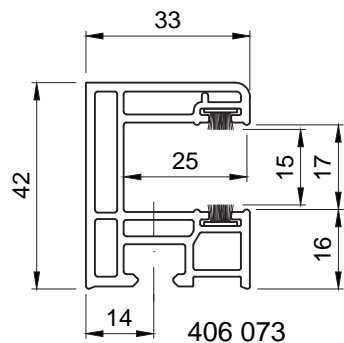

406 073

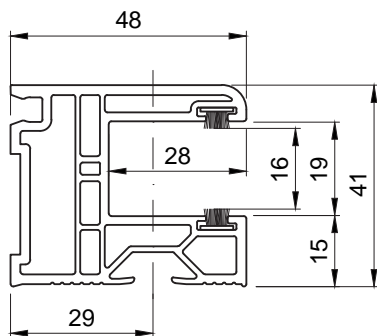

416 086

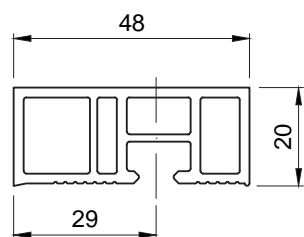

406 081

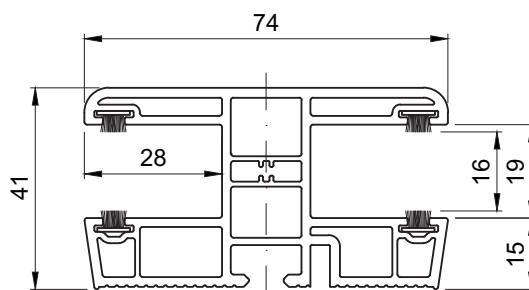

416 096

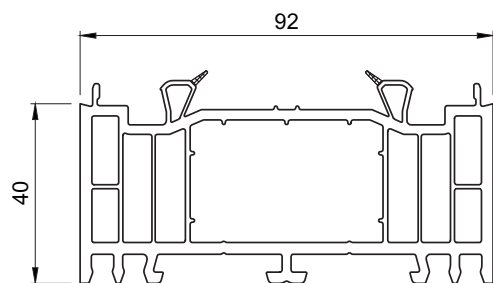

476 164

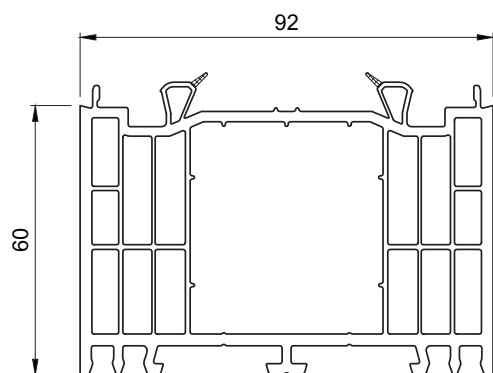

476 170

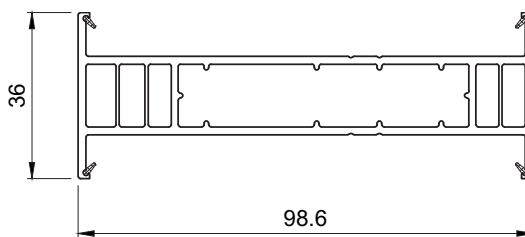

476 273

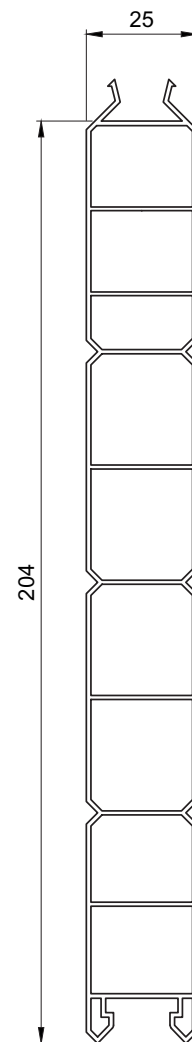

406 670





BluEvolution 82 **bE**

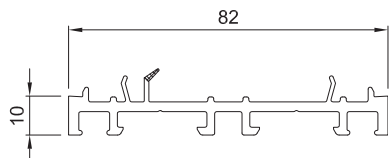

NP8200

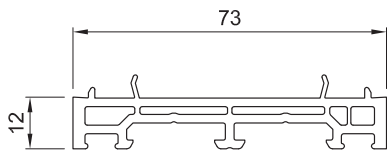

NP1120

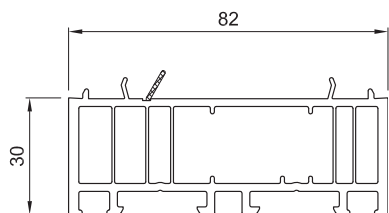

NP8300

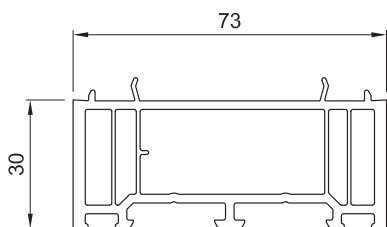

NP1350

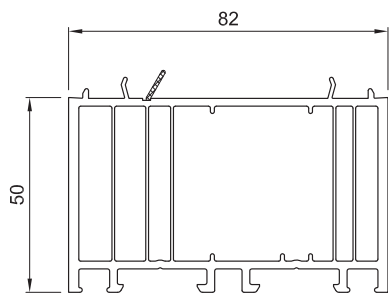

NP8500

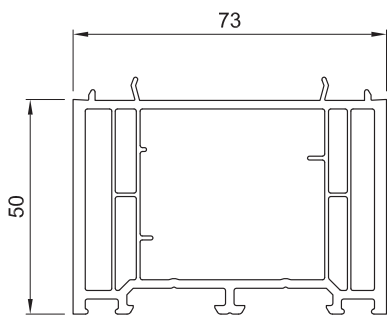

NP1550

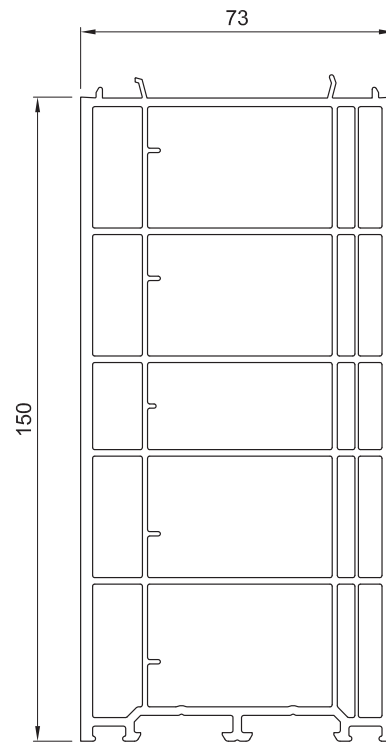

NP3300

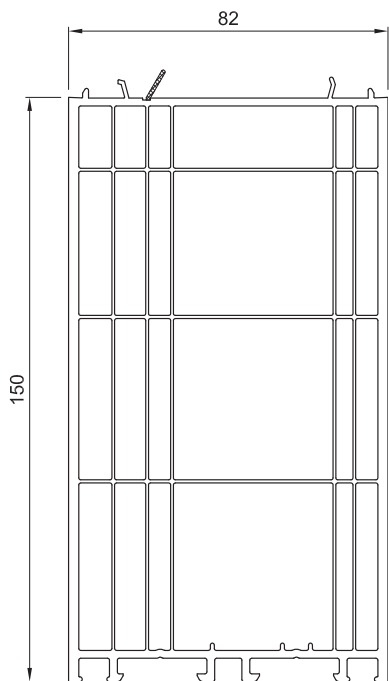

NP8700

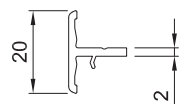

NP0190

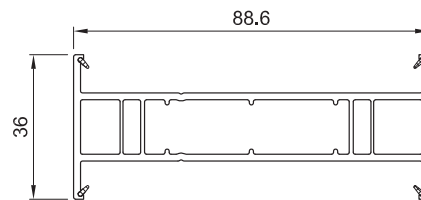

NP8170



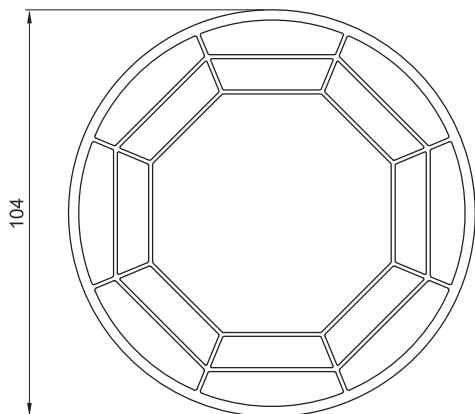
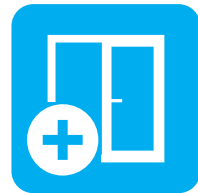

NP8160

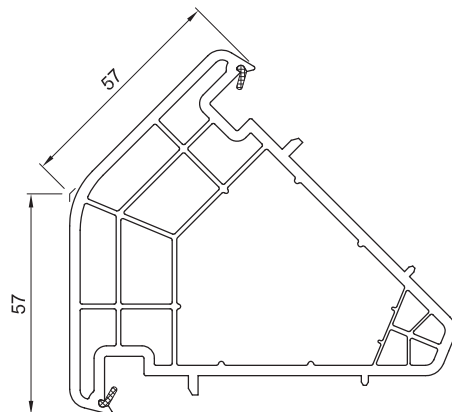

416240

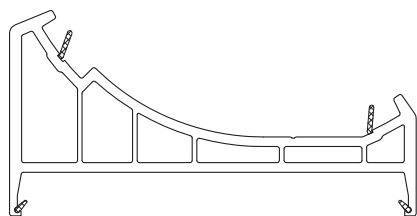

NP8150

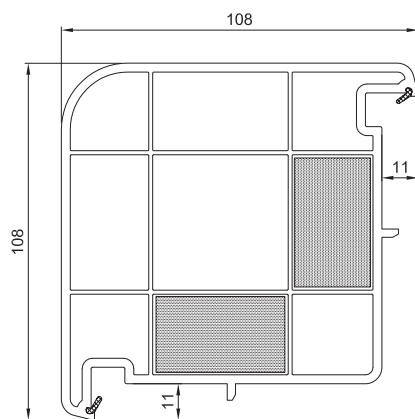

NP0100





(SAL 02)	(SAL 03)	(SAL 06)	(SAL 09)
(SAL 10)	(SAL 11)	(SAL 14)	(SAL 19)
(SAL 21)	(SAL 25)	(SAL 26)	(SAL 27)
(SAL 33)	(SAL 37)	(SAL 39)	(SAL 41)
(SAL 43)	(SAL 44)	(SAL 50)	(SAL 51)
(SAL 52)	(SAL 59)	(SAL 60)	(SAL 61)
(SAL 62)	(SAL 64)	(SAL 65)	(SAL 67)
(SAL 69)	(SAL 70)	(SAL 71)	(SAL 72)
(SAL 73)	(SAL 74)	(SAL 78)	(SAL 84)
(SAL 87)	(SAL 88)	(SAL 90)	



System Salamander - Paleta kolorów

Système Salamander - Palette de couleurs

Systeem Salamander - Kleurenpalet

System Salamander - Farbpalette

Sistema Salamander - Mazzetta colori



1/2017

