

OKO OKNA



Katalog techniczny



Catalogue Technique



Technische Catalogus



Technischer Katalog



Catalogo Tecnico

WindowsFactory
PVC | ALU | WOOD

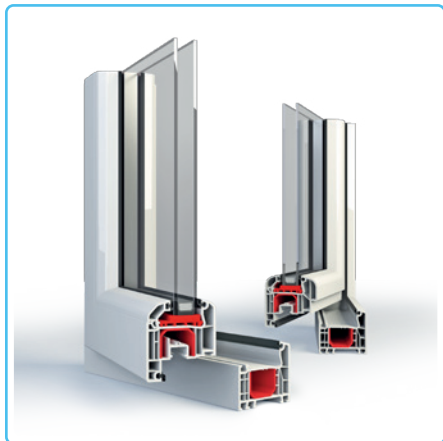
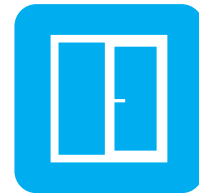

Ideal 4000



Ideal 4000 NEW



Ideal 5000



Ideal 8000



Blockprofil

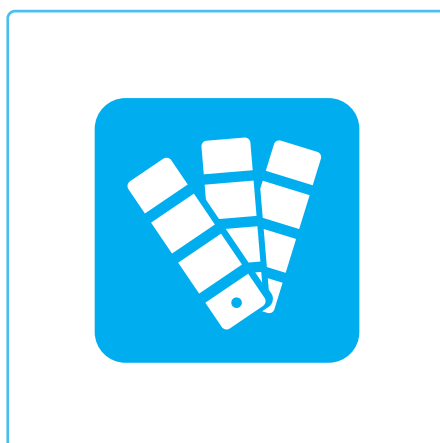
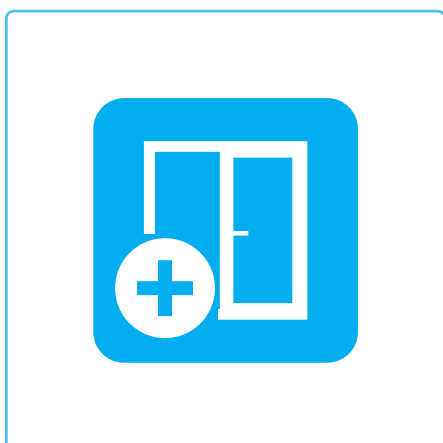

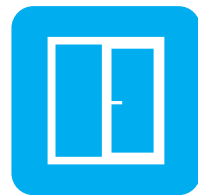

IDEAL 4000 | 5 komór | 2 uszczelki
Stal pokazana na rysunku może nie być stalą stosowaną standardowo.



IDEAL 4000 | 5 chambres | 2 joints
Renfort en acier présenté sur le dessin ci-dessus est en option.



IDEAL 4000 | 5 kamers | 2 afdichtingen
Staal die u op de tekening ziet, is niet standaard.



IDEAL 4000 | 5 Kammern | 2 Dichtungen
Der angewendete Stahlkern kann von dem abgebildeten Kern abweichen.



IDEAL 4000 | 5 camere | 2 guarnizioni
L'acciaio presentato sul disegno può essere un acciaio non standard.

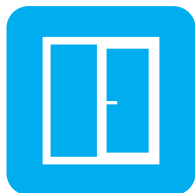

IDEAL 4000

OKO OKNA



IDEAL 4000 RENOVATION | 5 komór | 2 uszczelki

Stal pokazana na rysunku może nie być stalą stosowaną standardowo.

IDEAL 4000 RENOVATION | 5 chambres | 2 joints

Renfort en acier présenté sur le dessin ci-dessus est en option.

IDEAL 4000 RENOVATIE | 5 kamers | 2 afdichtingen

Staal die u op de tekening ziet, is niet standaard.

IDEAL 4000 RENOVIERUNG | 5 Kammern | 2 Dichtungen

Der angewendete Stahlkern kann von dem abgebildeten Kern abweichen.

IDEAL 4000 RINNOVAZIONE | 5 camere | 2 guarnizioni

L'acciaio presentato sul disegno può essere un acciaio non standard.



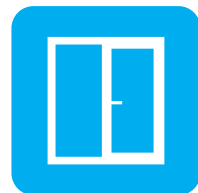

IDEAL 4000 MONOBLOCK | 5 komór | 2 uszczelki
Stal pokazana na rysunku może nie być stalą stosowaną standardowo.



IDEAL 4000 MONOBLOCK | 5 chambres | 2 joints
Renfort en acier présenté sur le dessin ci-dessus est en option.



IDEAL 4000 MONOBLOCK | 5 kamers | 2 afdichtingen
Staal die u op de tekening ziet, is niet standaard.



IDEAL 4000 MONOBLOCK | 5 Kammern | 2 Dichtungen
Der angewendete Stahlkern kann von dem abgebildeten Kern abweichen.



IDEAL 4000 MONOBLOCK | 5 camere | 2 guarnizioni
L'acciaio presentato sul disegno può essere un acciaio non standard.

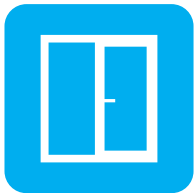

IDEAL 4000

140x01 - 140x20

**OKO
OKNA**

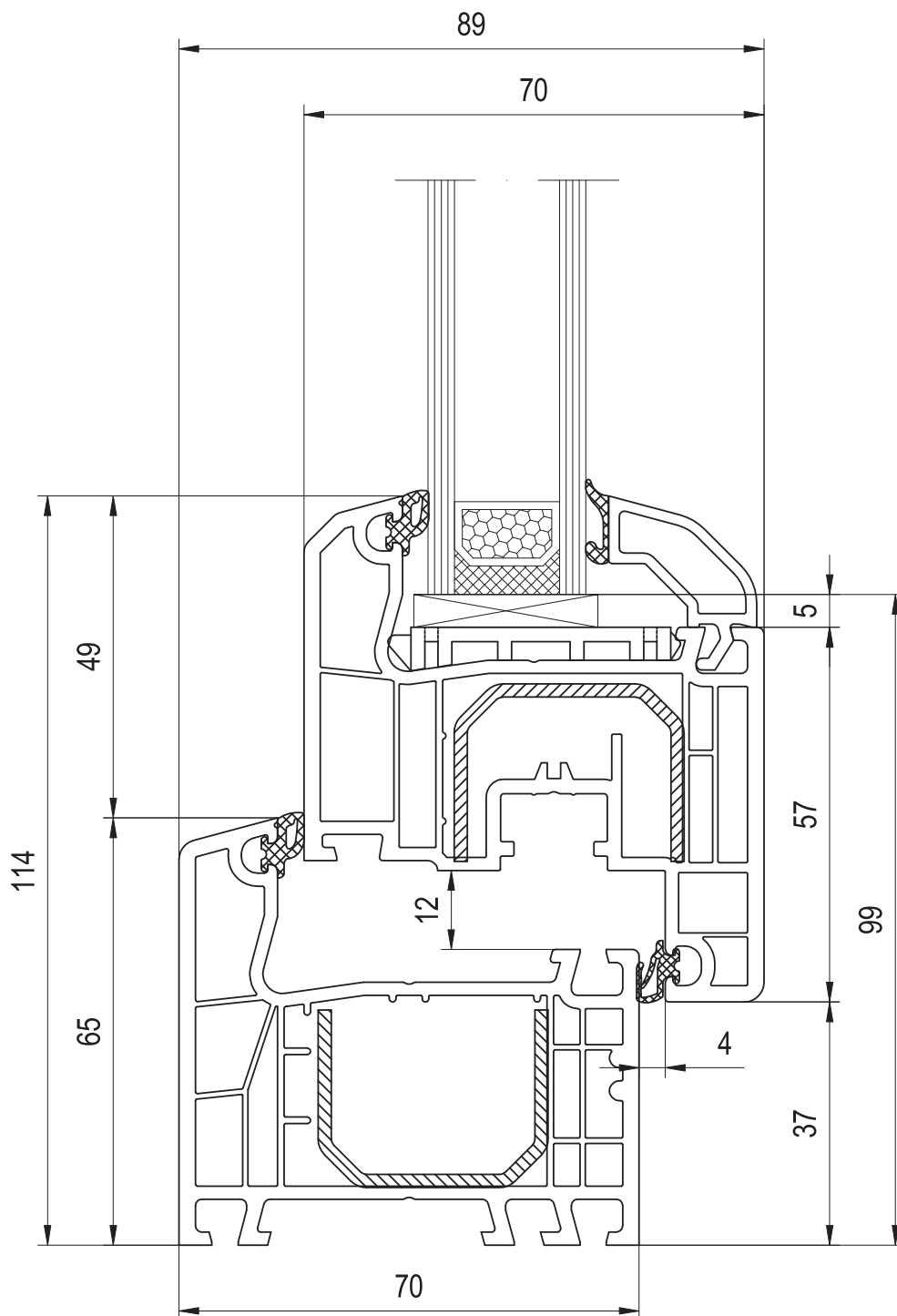

Skrzydło Soft-line 

Ouvrant Soft-line 

Vleugel Soft-line 

Flügel Soft-line 

Ante Soft-line 

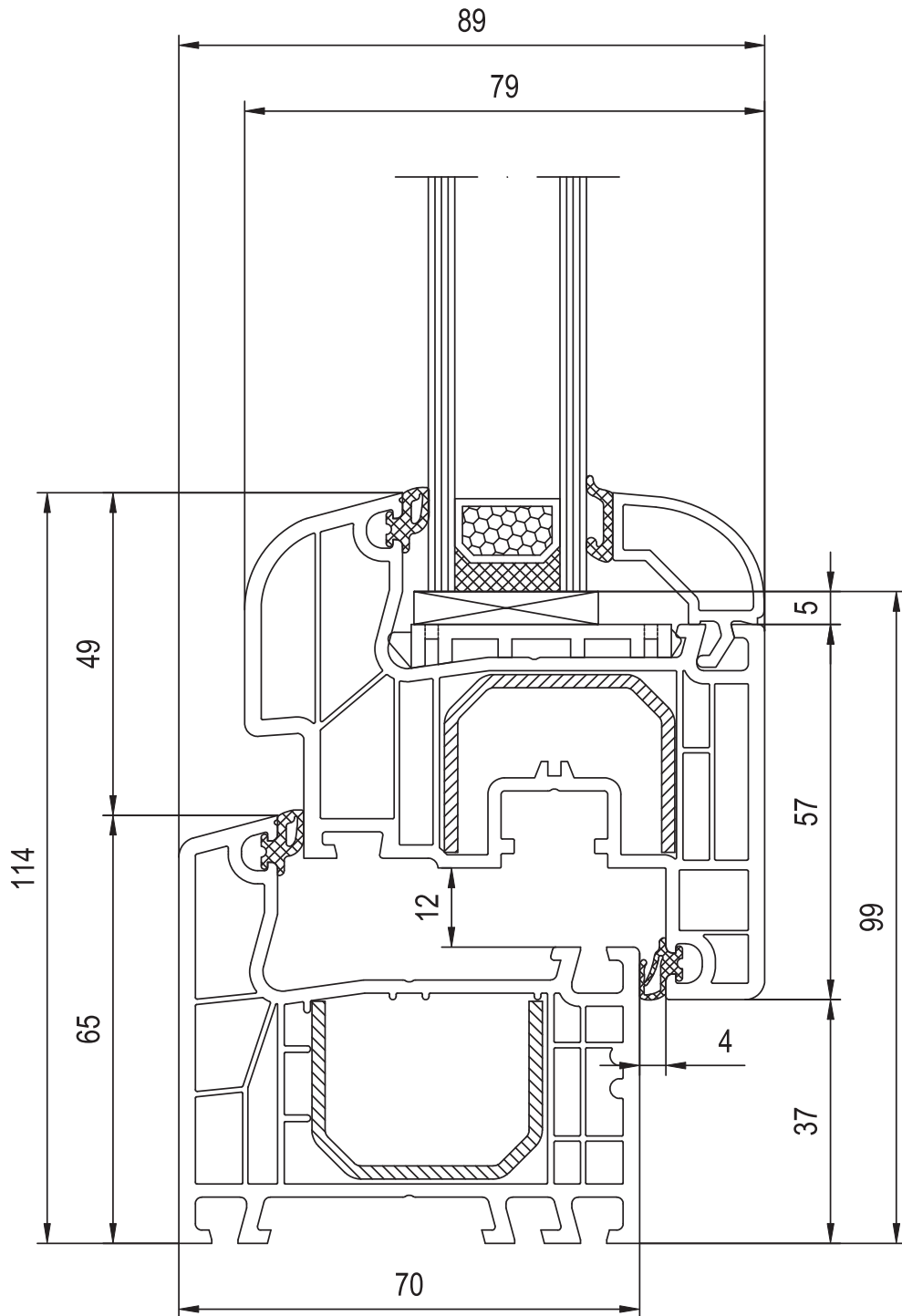

-  Skrzydło Round-line
-  Ouvrant Round-line
-  Vleugel Round-line
-  Flügel Round-line
-  Ante Round-line

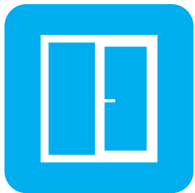

IDEAL 4000

140x01

**OKO
OKNA**

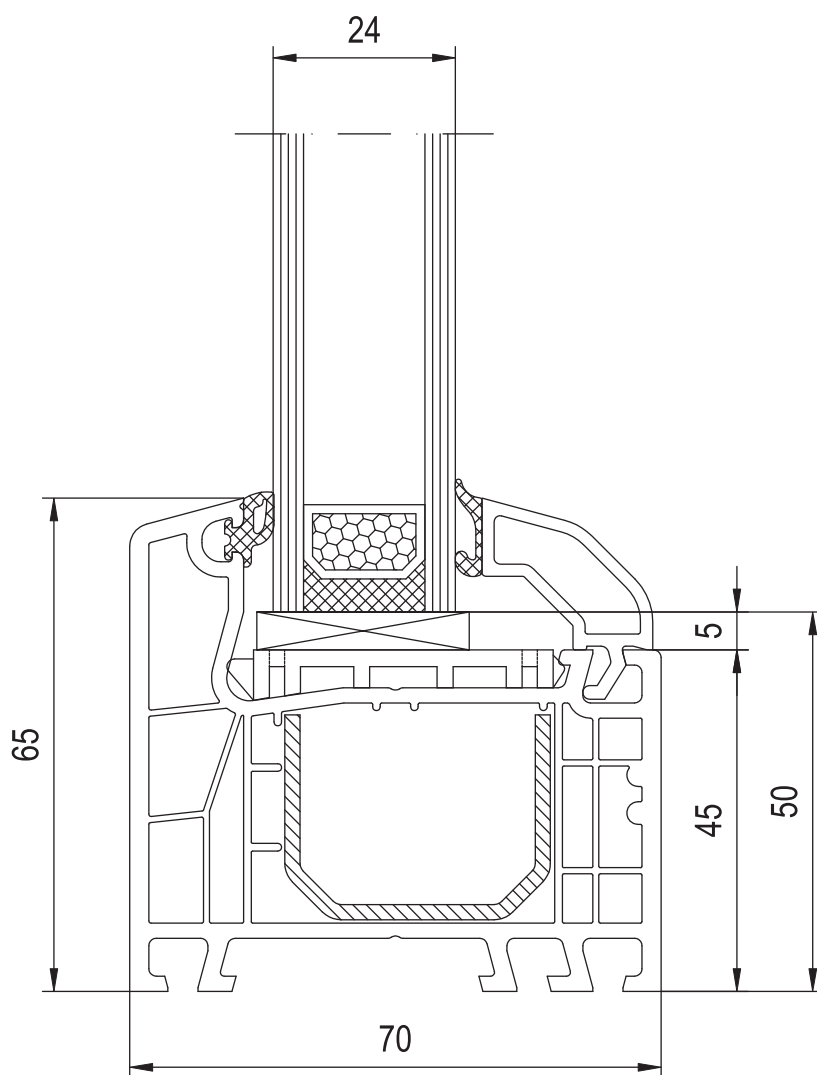

Szklenie stałe - standardowa rama okienna



Fixe - dormant de fenêtre standard



Vast raam - raamkader standaard









Festverglasung - Fensterrahmen standard

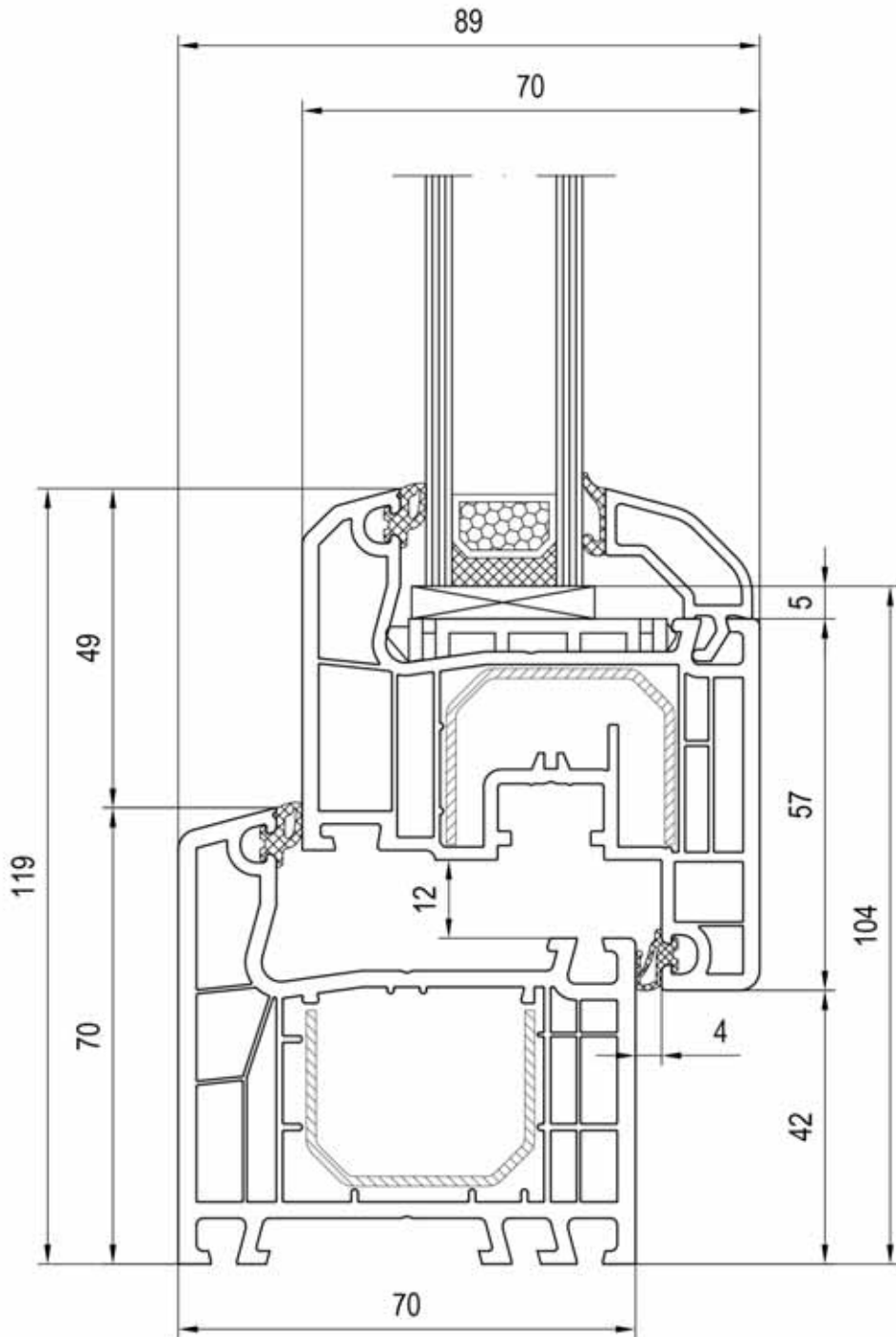

Serramento fisso - Telaio finestra standard





-  Skrzydło okienne + rama drzwiowa
-  Ouvrant avec dormant de porte
-  Vleugel + kader
-  Fensterflügel + Türrahmen
-  Anta finestra + telaio della porta

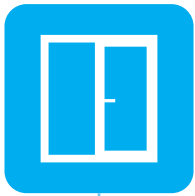

IDEAL 4000

140x02 - 140x22

**OKO
OKNA**

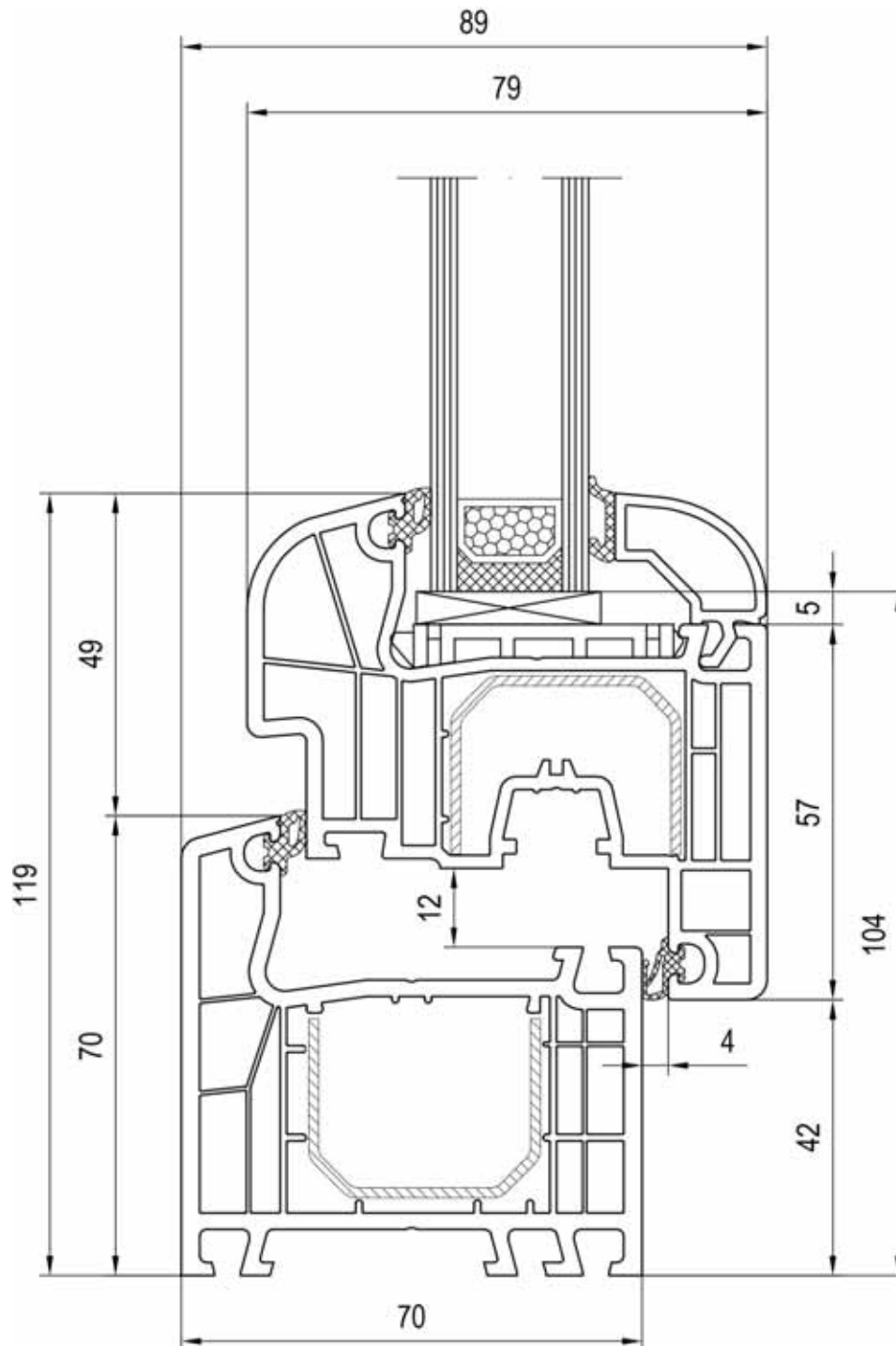

Profil okienny z szeroką ramą 140x02

Profil de fenêtre + dormant plus haut 140x02

Raamprofiel met verhoogde kader 140x02

Fensterprofil mit breitem Rahmen 140x02

Profilo della finestra con telaio maggiore 140x02



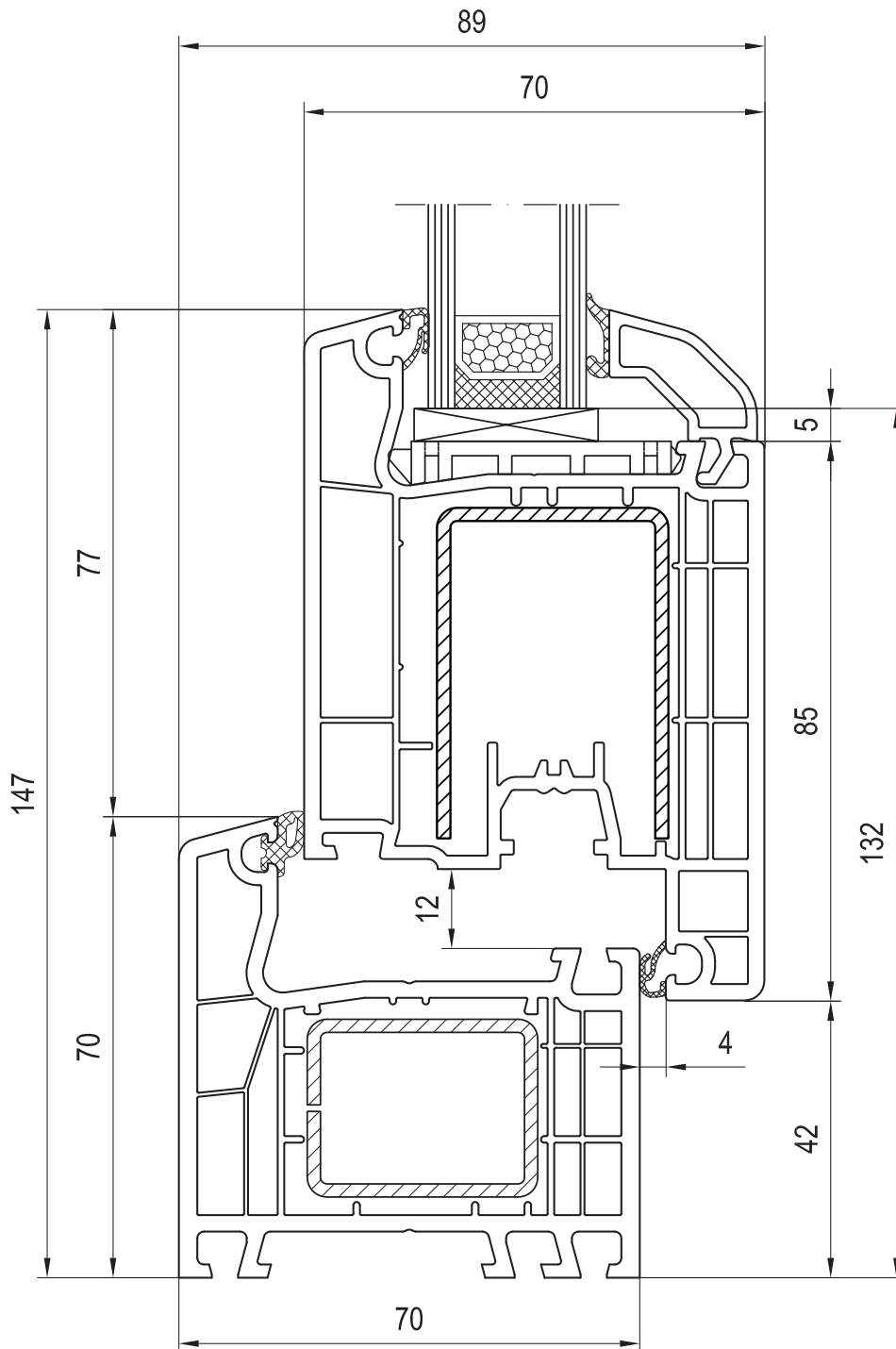

Drzwi typu B lub profil drzwi tarasowych, otwierane do wewnątrz



Porte type B ou profil de porte de passage avec seuil, ouverture vers l'intérieur



Deur versie B, terras profiel met drempel, naar binnen opendraaiend



Nebeneingangstür oder Terrassentür mit Schwelle, nach Innen öffnend



Porta la versione „B” o profilo portaveranda con soglia, l'apertura verso interno



IDEAL 4000

140x02 - 140x31

**OKO
OKNA**

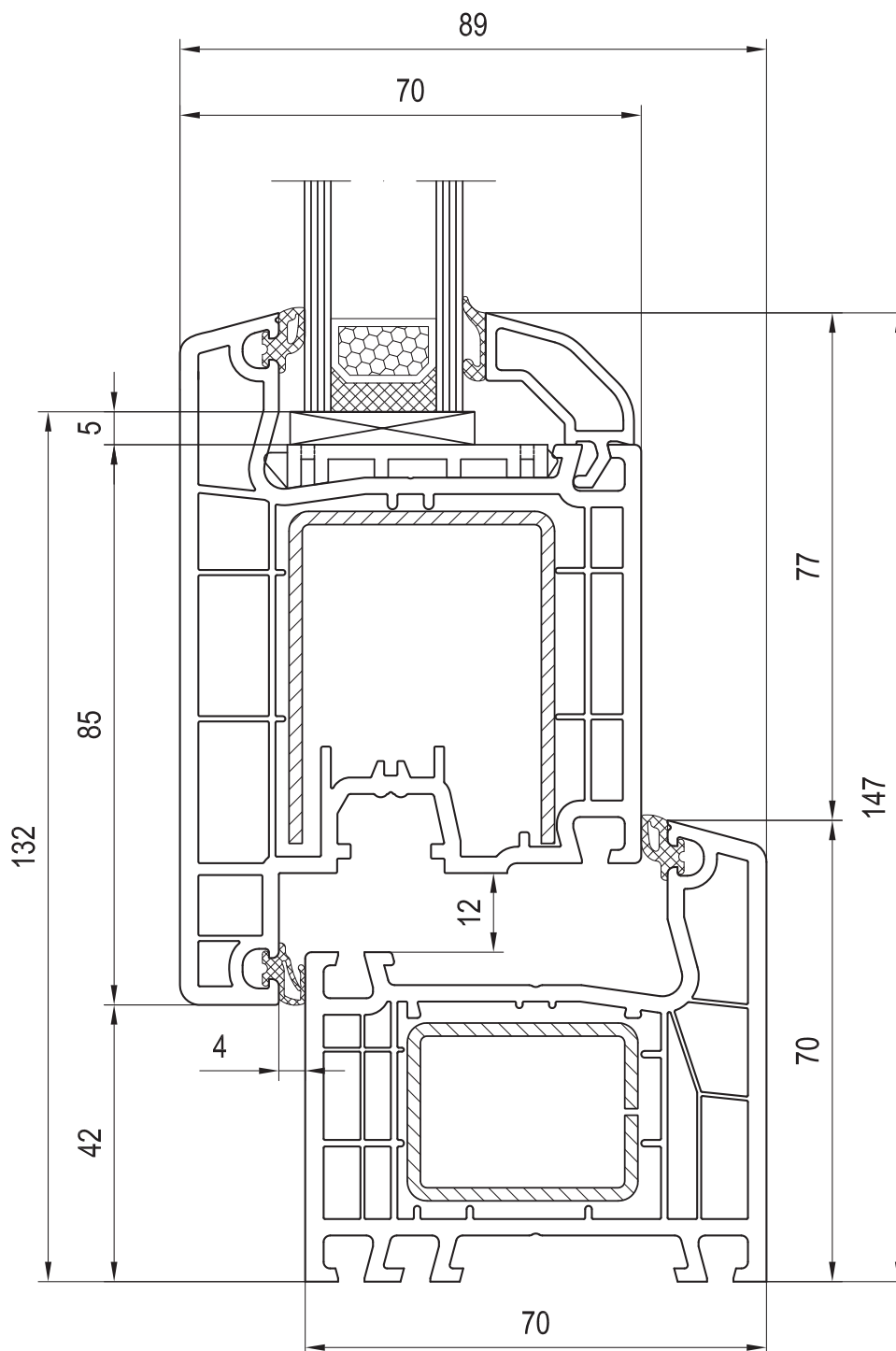

Drzwi typu B lub profil drzwi tarasowych, otwierane na zewnątrz

Porte type B ou profil de porte de passage, ouverture vers l'extérieur





Deur versie B, terras profiel, naar buiten opendraaiend

Nebeneingangstür oder Terrassentür mit Schwelle, nach Aussen öffnend

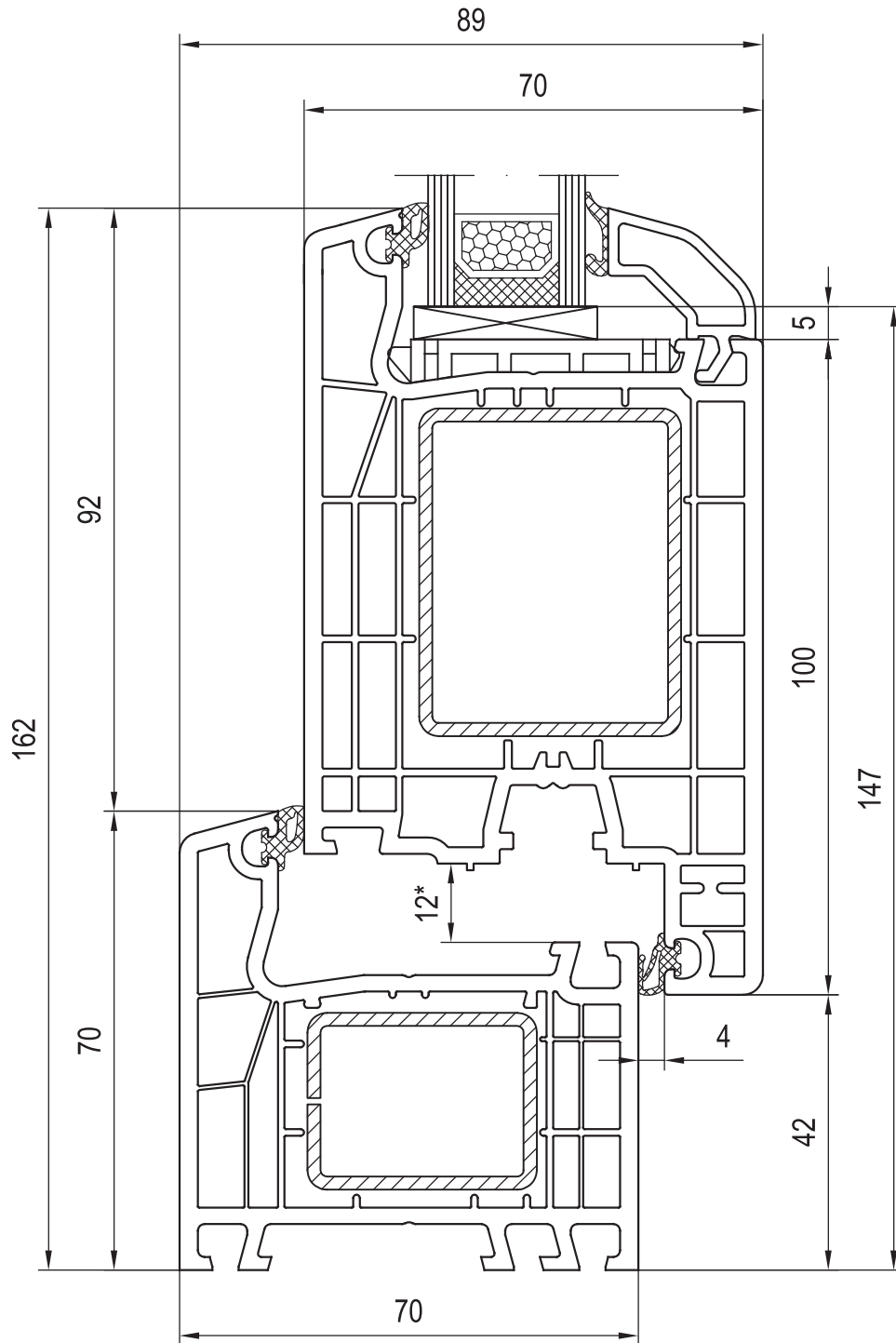
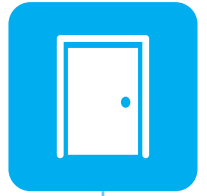
Porta la versione „B” o profilo portaveranda, l'apertura verso esterno





-  Drzwi wejściowe typu A, otwierane do wewnątrz
-  Porte d'entrée type A, ouverture vers l'intérieur
-  Deur versie A, naar binnen opendraaiend
-  Eingangstür Version „A“ nach Innen öffnend
-  Porta la versione „A“, l'apertura verso interno



IDEAL 4000

140x02 - 140x35

eko
okna

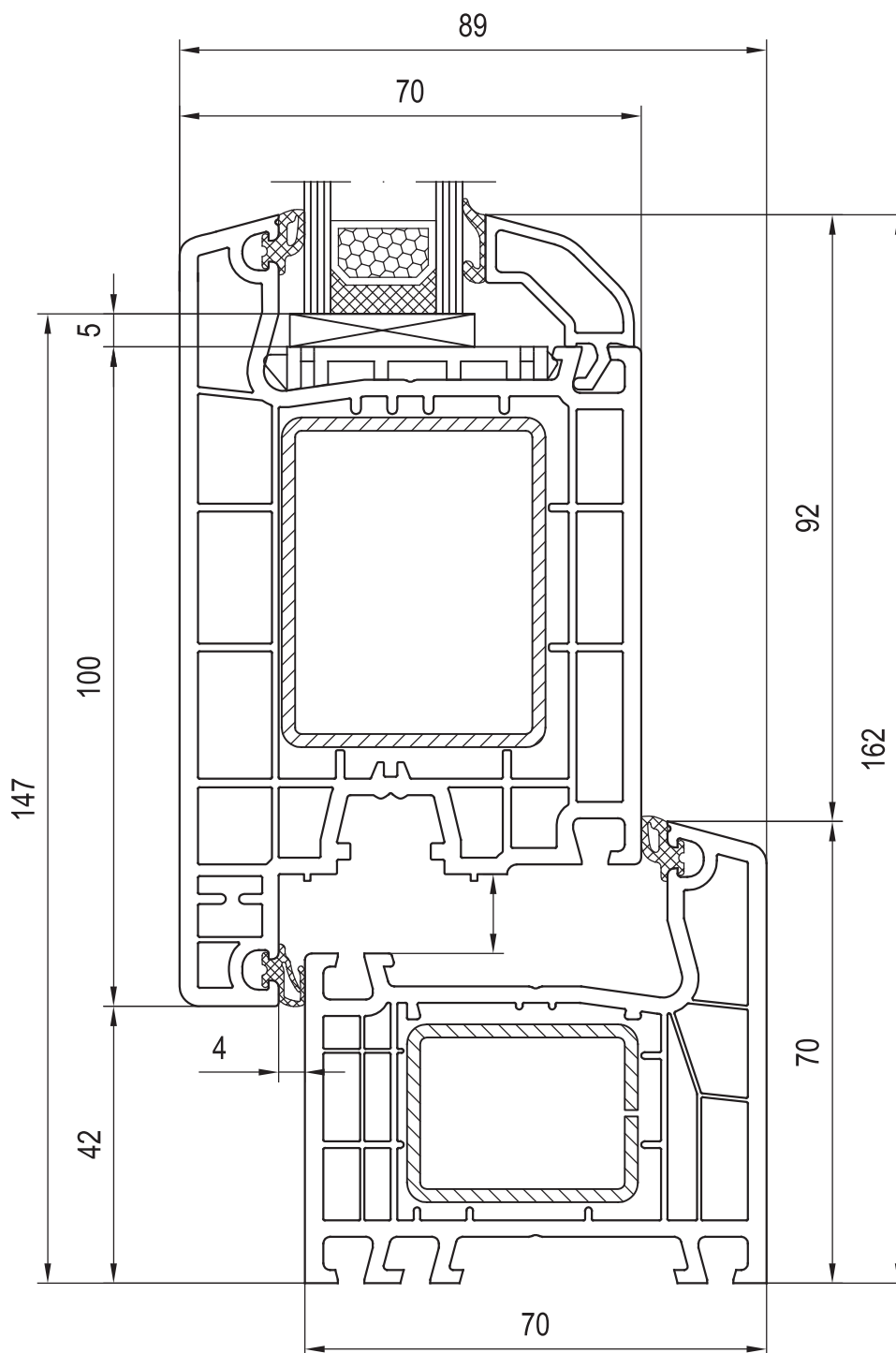

Drzwi wejściowe typu A, otwierane na zewnątrz



Porte d'entrée type A, ouverture vers l'extérieur



Deur versie A, naar buiten opendraaiend









Eingangstür Version „A“ nach Aussen öffnend

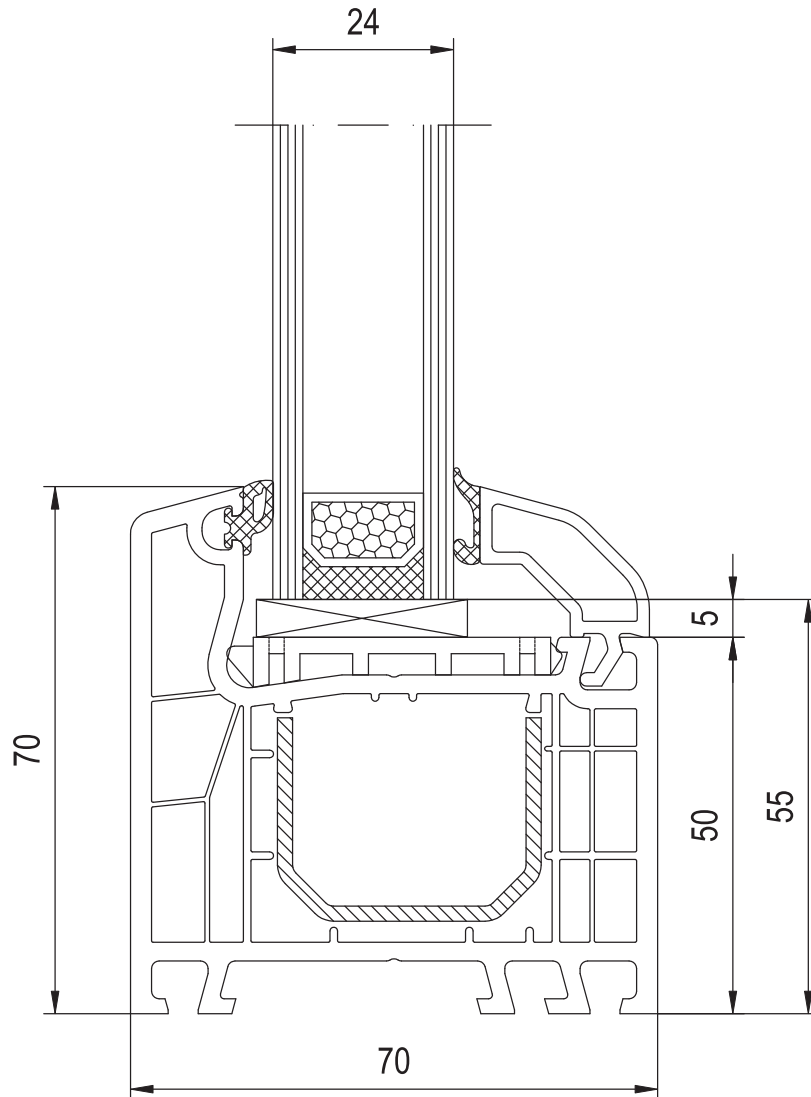

Porta la versione „A“, l'apertura verso esterno





-  Stałe szklenie - rama 140x02
-  Fixe - dormant 140x02
-  Vast raam - kader 140x02
-  Festverglasung - Rahmen 140x02
-  Serramento fisso - telaio 140x02

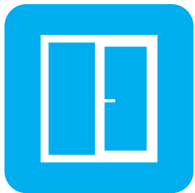

IDEAL 4000

140x10 - 140x20

**OKO
OKNA**

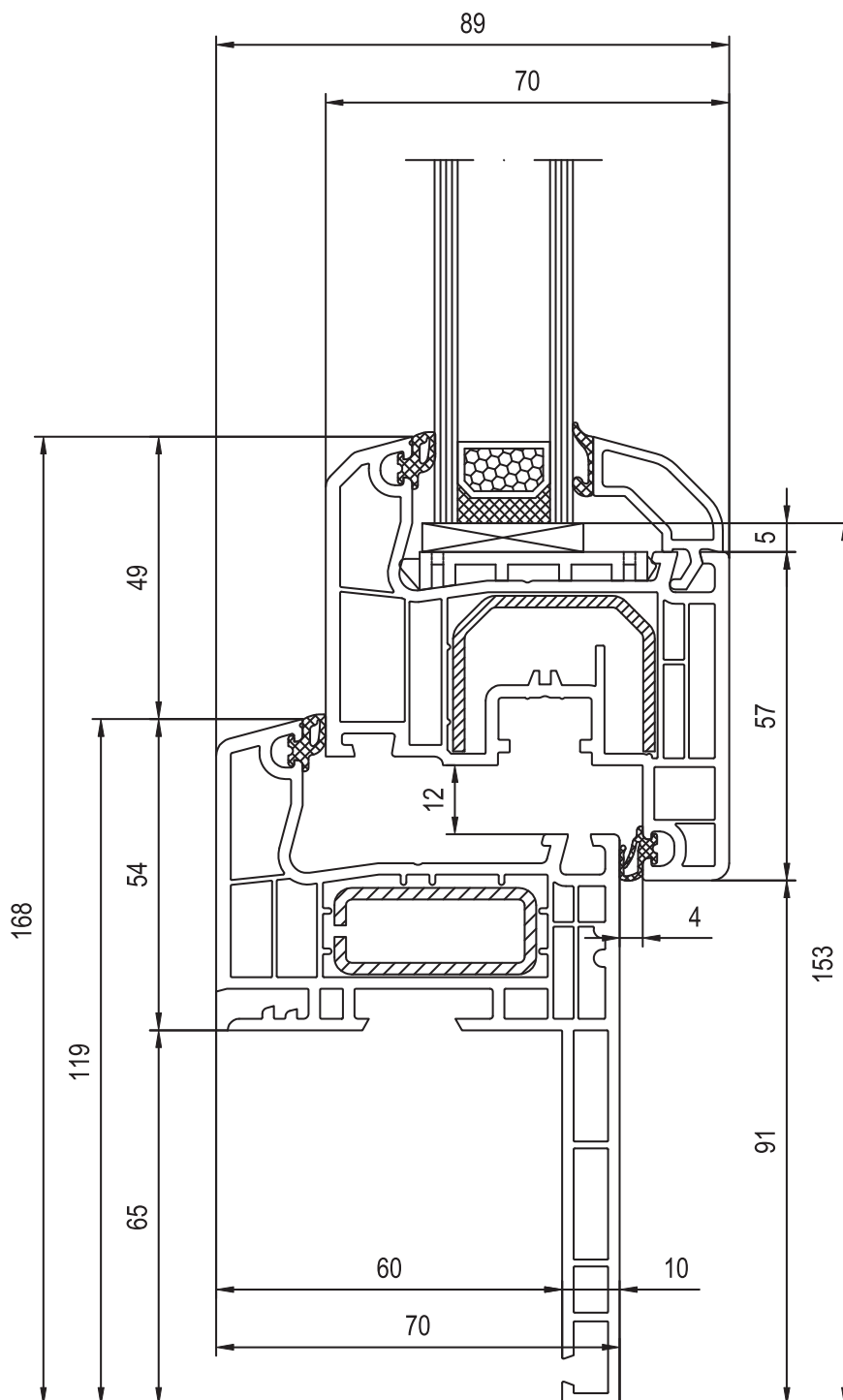

RENOWACJA - Płetwa 65 mm z prostym skrzydłem



RENOVATION - Aile de 65 mm avec ouvrant plat



RENOVATIE - Lip 65 mm rechte vleugel









RENOVIERUNG - Flosse 65 mm mit Flächen versetzt

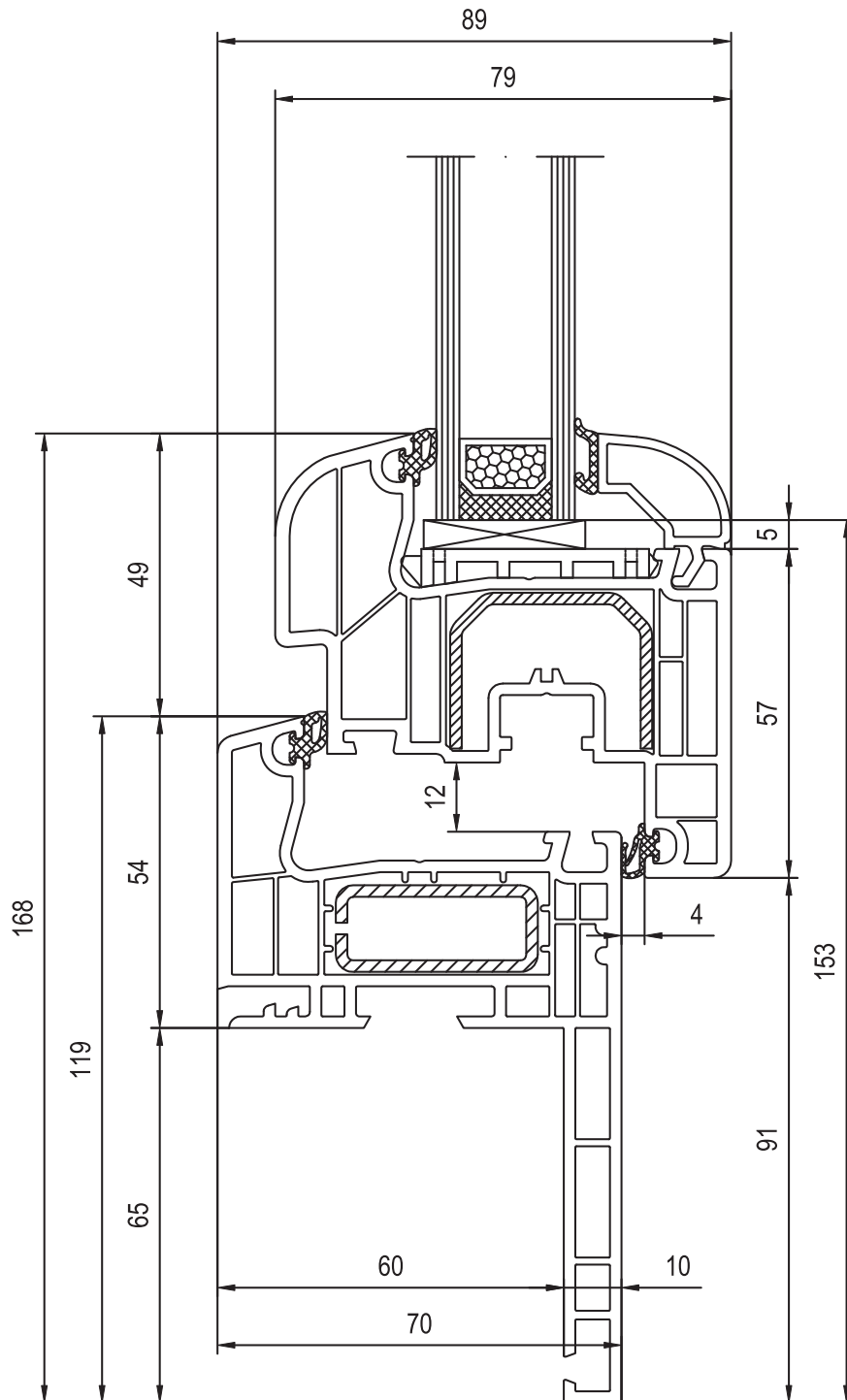
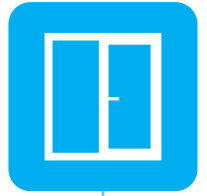

RINNOVAZIONE - Aletta da 65 mm con anta dritta





-  RENOWACJA - Płetwa 65 mm z okrągłym skrzydłem
-  RENOVATION - Aile de 65 mm avec ouvrant arrondi
-  RENOVATIE - Lip 65 mm afgeronde vleugel
-  RENOVIERUNG - Flosse 65 mm mit rundem Flügel
-  RINNOVAZIONE - Aletta da 65 mm con anta arrotondata

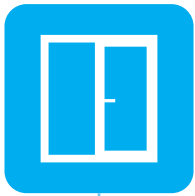

IDEAL 4000

140x15 - 140x20

**OKO
OKNA**

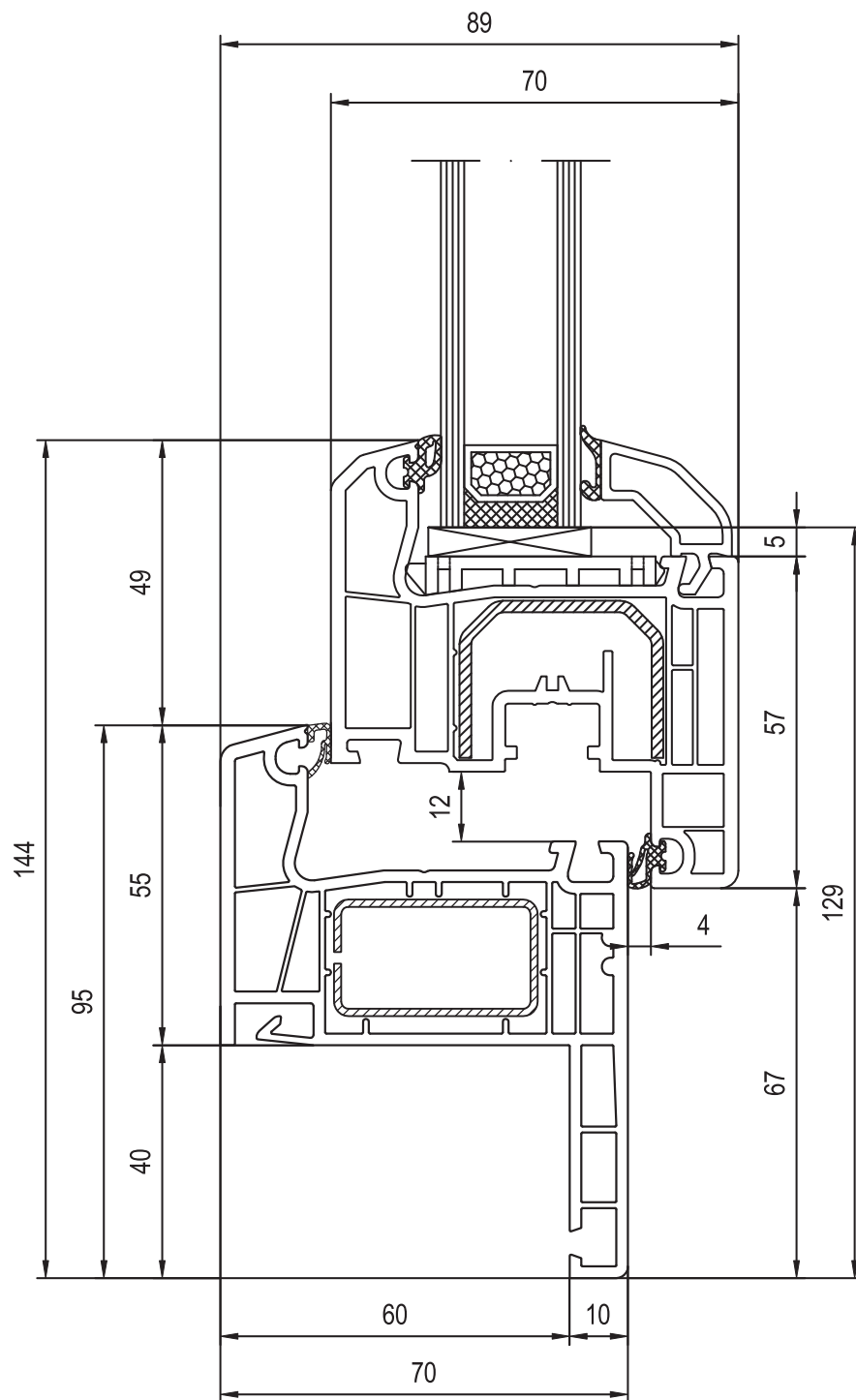

RENOWACJA - Płetwa 40 mm z prostym skrzydłem



RENOVATION - Aile de 40 mm avec ouvrant plat



RENOVATIE - Lip 40 mm rechte vleugel









RENOVIERUNG - Flosse 40 mm mit Flächen versetzt

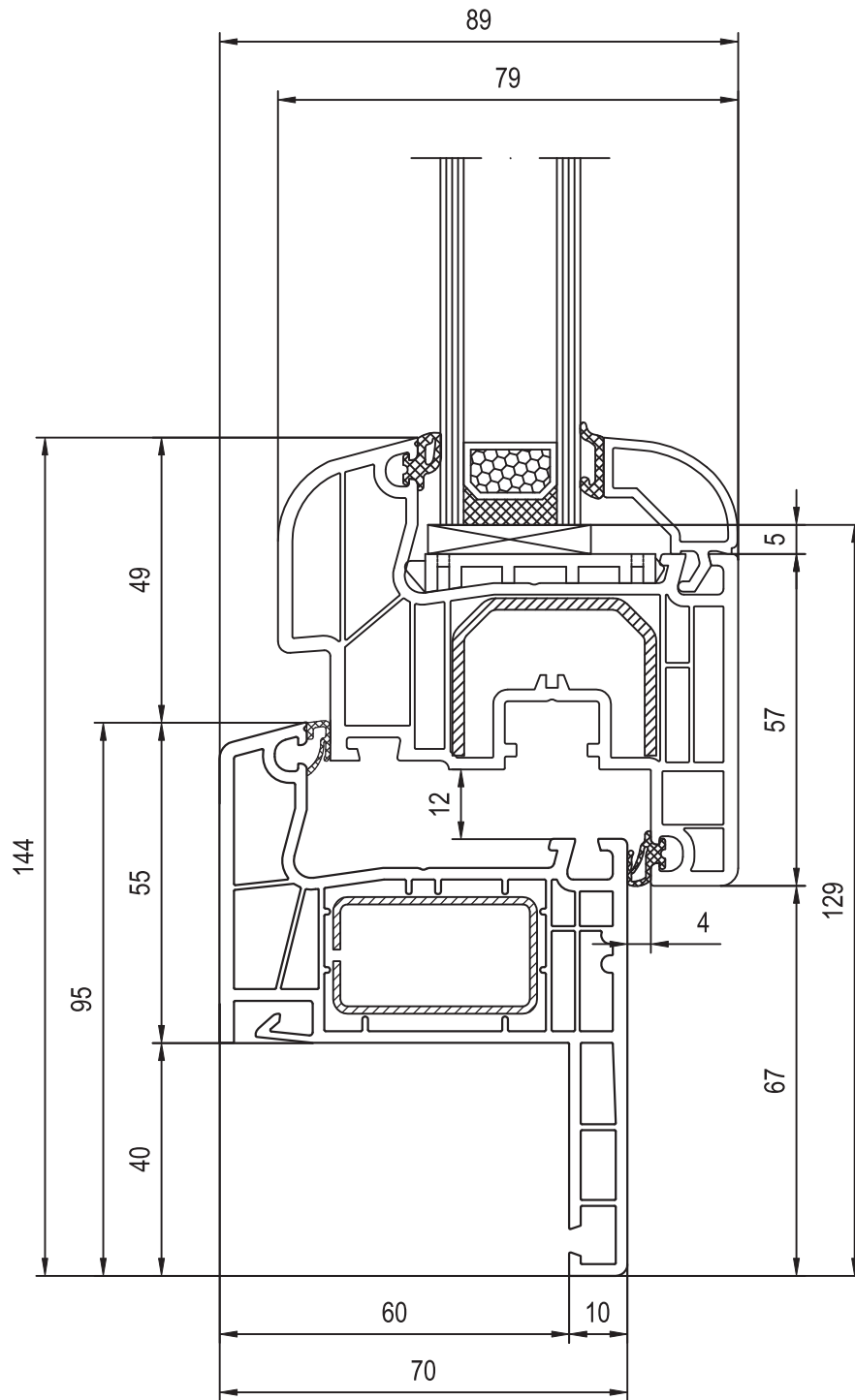

RINNOVAZIONE - Aletta da 40 mm con anta dritta





-  RENOWACJA - Płetwa 40 mm z okrągłym skrzydłem
-  RENOVATION - Aile de 40 mm avec ouvrant arrondi
-  RENOVATIE - Lip 40 mm afgeronde vleugel
-  RENOVIERUNG - Flosse 40 mm mit rundem Flügel
-  RINNOVAZIONE - Aletta da 40 mm con anta arrotondata

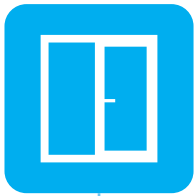

IDEAL 4000

140x17 - 140x20

**OKO
OKNA**

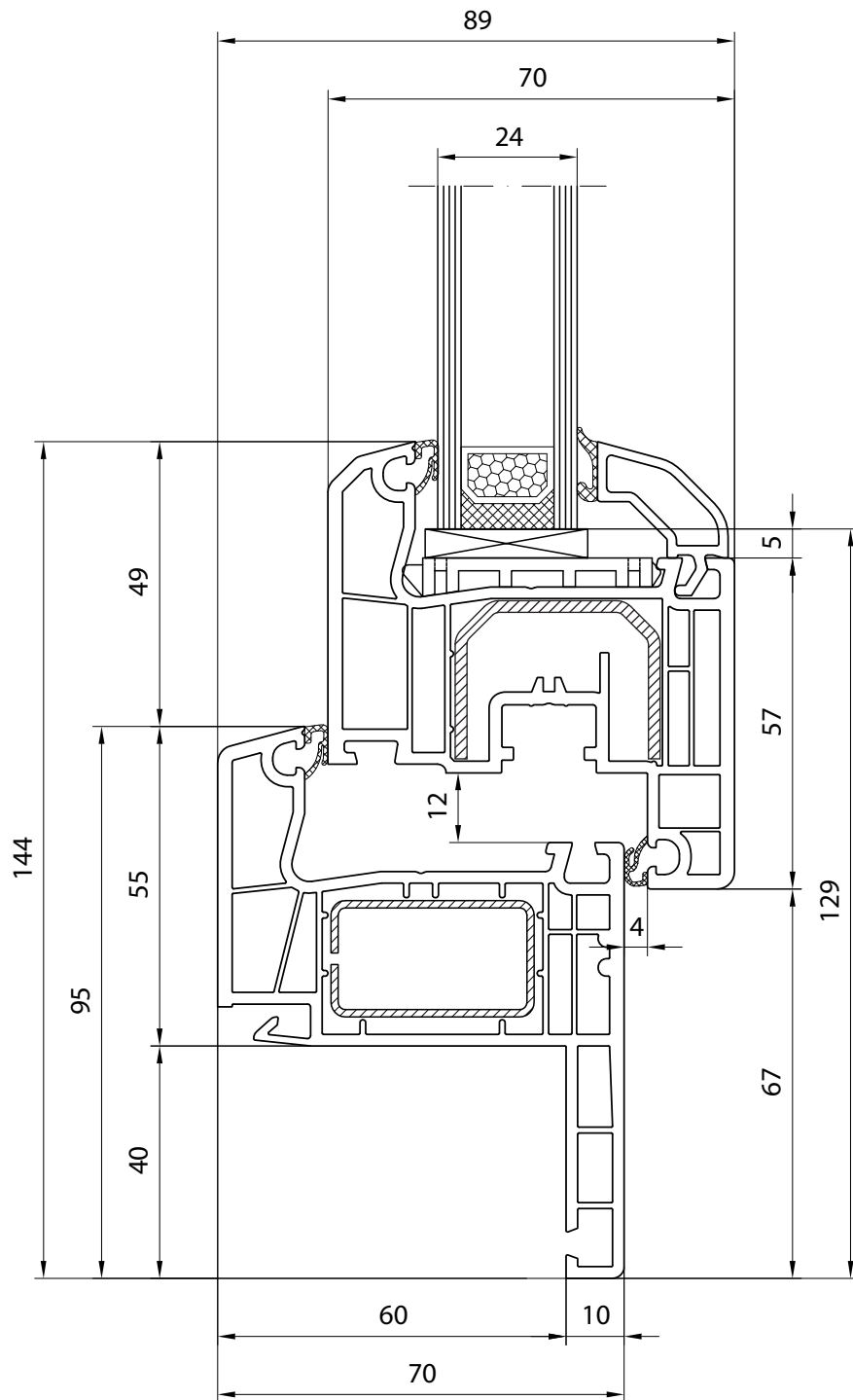

RENOWACJA - Płetwa 40 mm z prostym skrzydłem



RENOVATION - Aile de 40 mm avec ouvrant plat



RENOVATIE - Lip 40 mm rechte vleugel









RENOVIERUNG - Flosse 40 mm mit Flächen versetzt

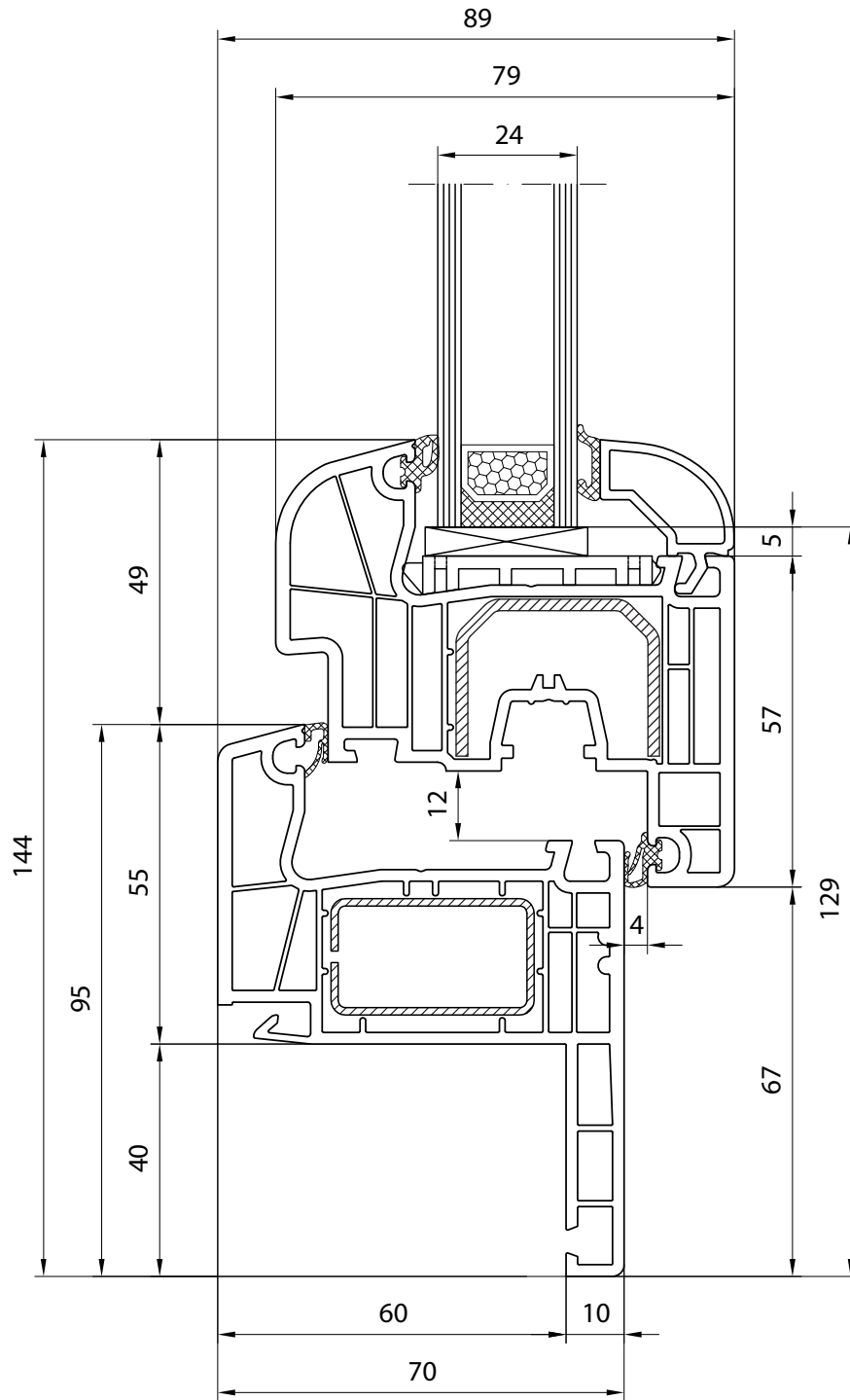

RINNOVAZIONE - Aletta da 40 mm con anta dritta





-  RENOWACJA - Płetwa 40 mm z okrągłym skrzydłem
-  RENOVATION - Aile de 40 mm avec ouvrant arrondi
-  RENOVATIE - Lip 40 mm afgeronde vleugel
-  RENOVIERUNG - Flosse 40 mm mit rundem Flügel
-  RINNOVAZIONE - Aletta da 40 mm con anta arrotondata

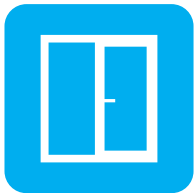

IDEAL 4000

140x20 - 140x20

**OKO
OKNA**

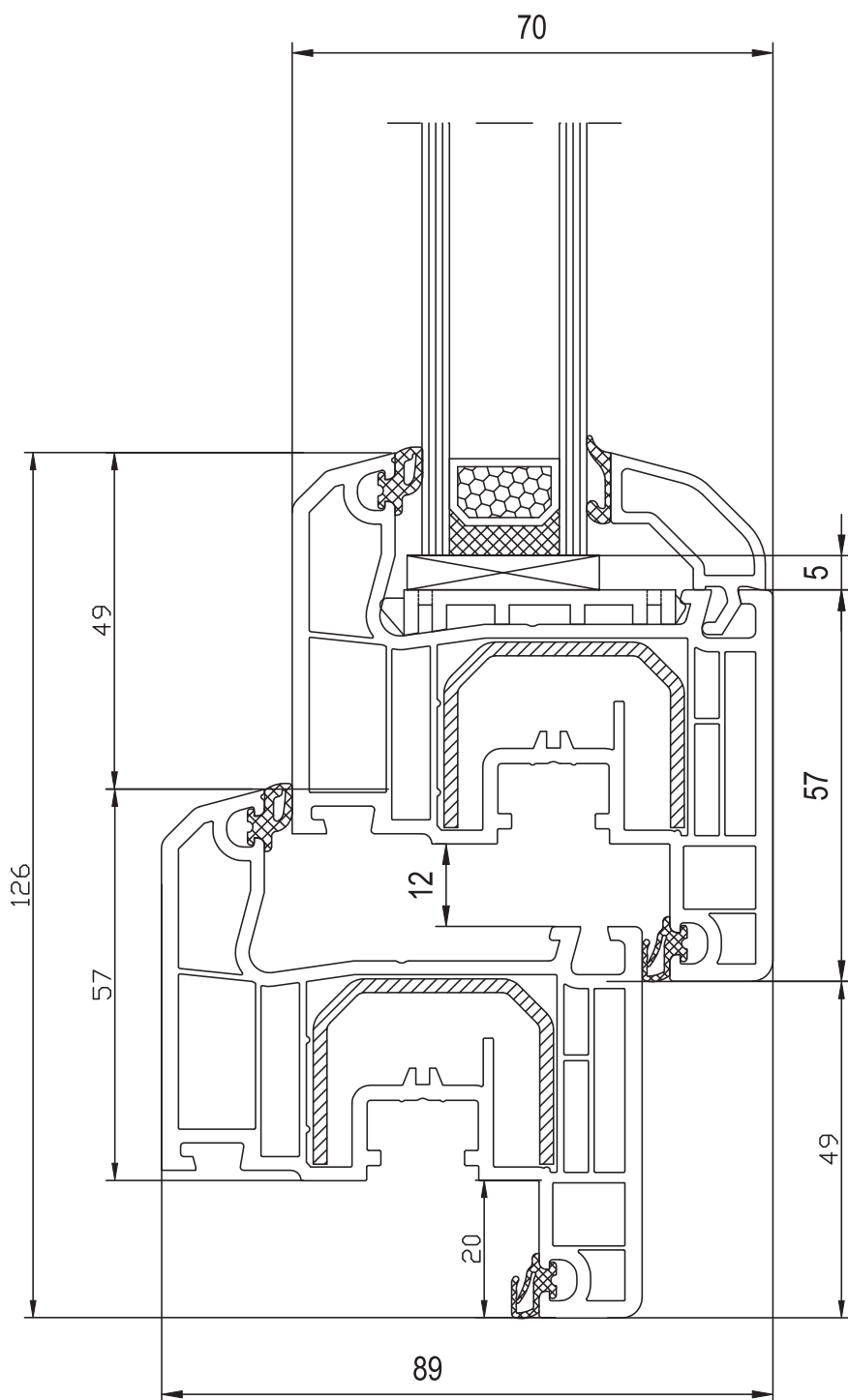

RENOWACJA - Płetwa 20 mm z prostym skrzydłem

RENOVATION - Aile de 20 mm dormant d'ouvrant plat

RENOVATIE - Lip 20 mm kader van de vleugel

RENOVIERUNG - Flosse 20 mm Flügelrahmen

RINNOVAZIONE - Aletta da 20 mm anta su anta



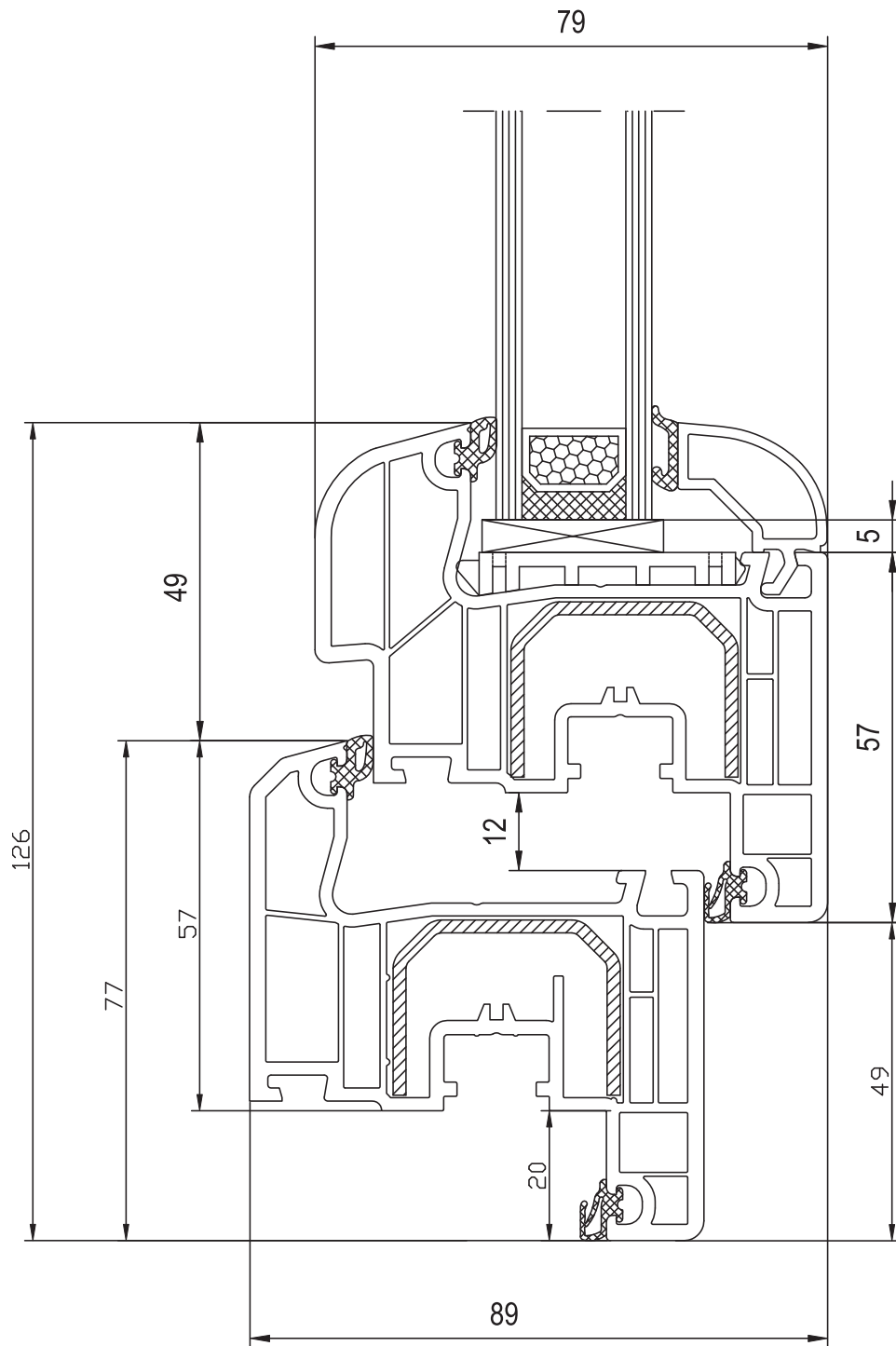

RENOWACJA - Płetwa 20 mm z prostą ramą i okrągłym skrzydłem



RENOVATION - Aile de 20 mm, dormant d'ouvrant arrondi



RENOVATIE - Lip 20 mm, kader van rechte vleugel, afgeronde vleugel



RENOVIERUNG - Flosse 20 mm Flächenversetzter Flügelrahmen, Flügel Rung



RINNOVAZIONE - Aletta da 20 mm, telaio dell'anta soft-line, battente arrotondato

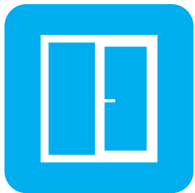

IDEAL 4000

140x12 - 140x20

**OKO
OKNA**

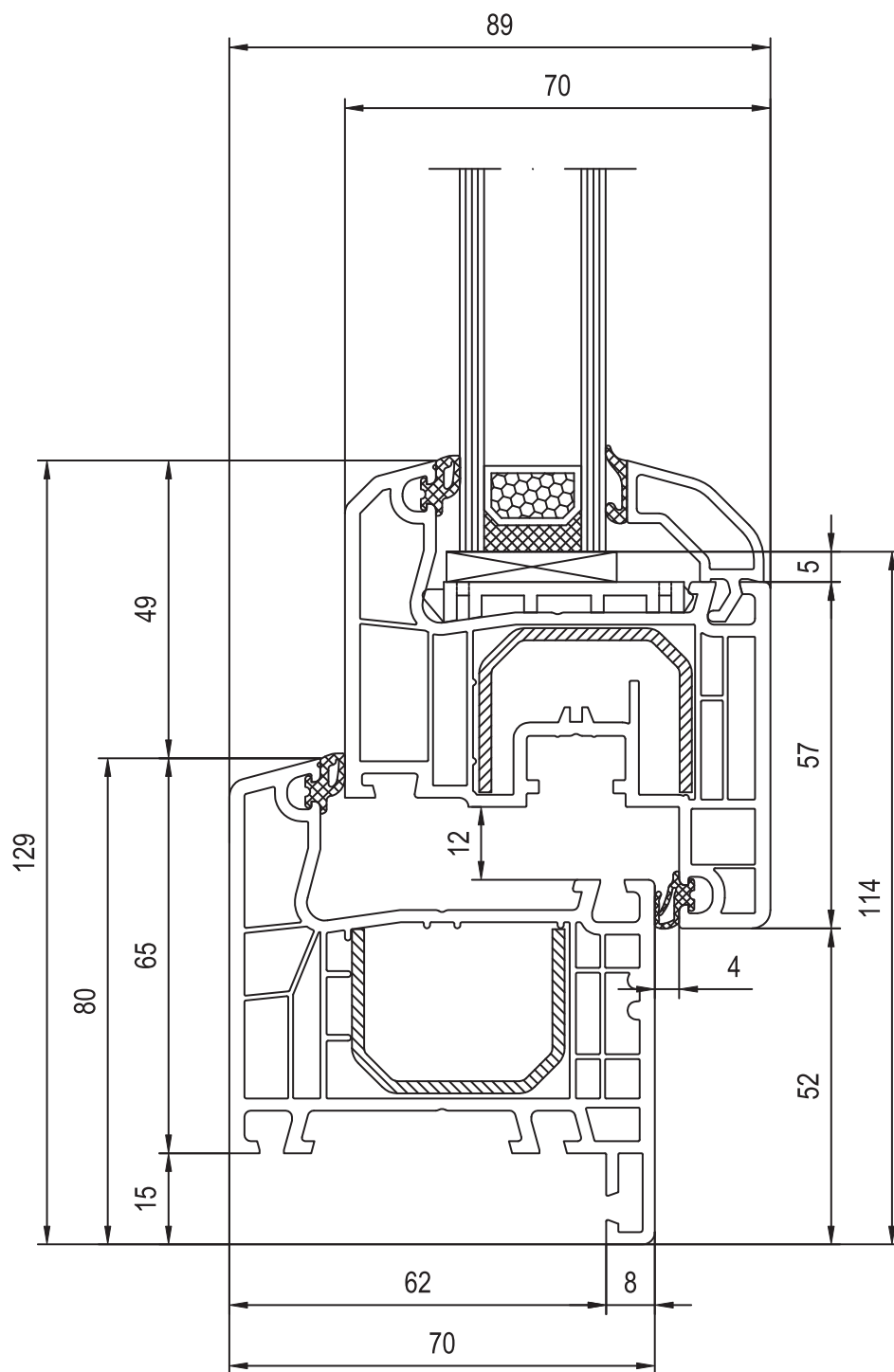

MONOBLOCK - Skrzydło Soft-line



MONOBLOC - Ouvrant Soft-line



MONOBLOK - Vleugel Soft-line



MONOBLOCK - Flügel Soft-line



MONOBLOCK - Ante Soft-line



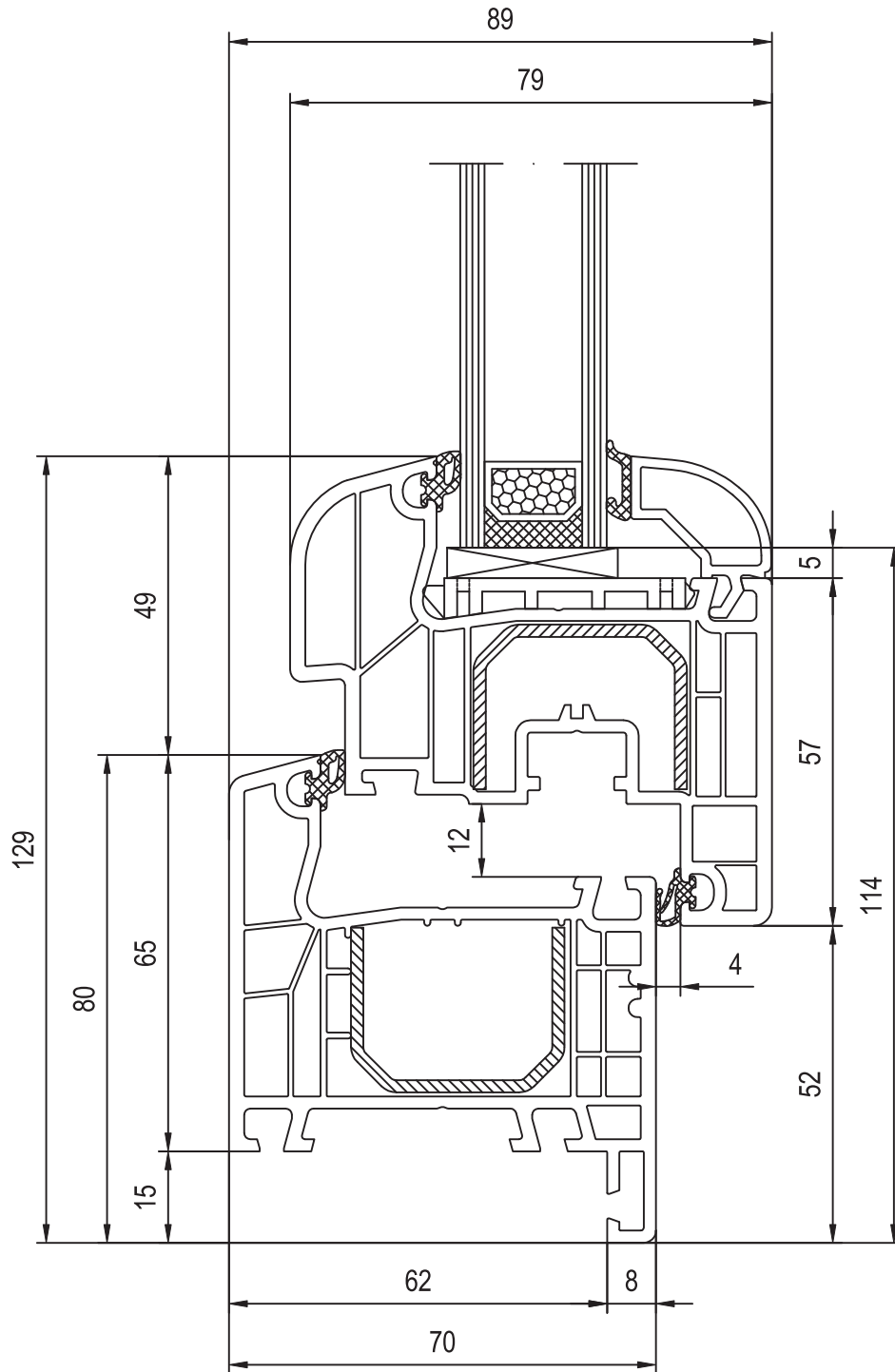

-  MONOBLOCK - Skrzydło Round-line
-  MONOBLOC - Ouvrant Round-line
-  MONOBLOK - Vleugel Round-line
-  MONOBLOCK - Flügel Round-line
-  MONOBLOCK - Ante Round-line

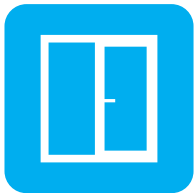

IDEAL 4000

140x14 - 140x20

**OKO
OKNA**

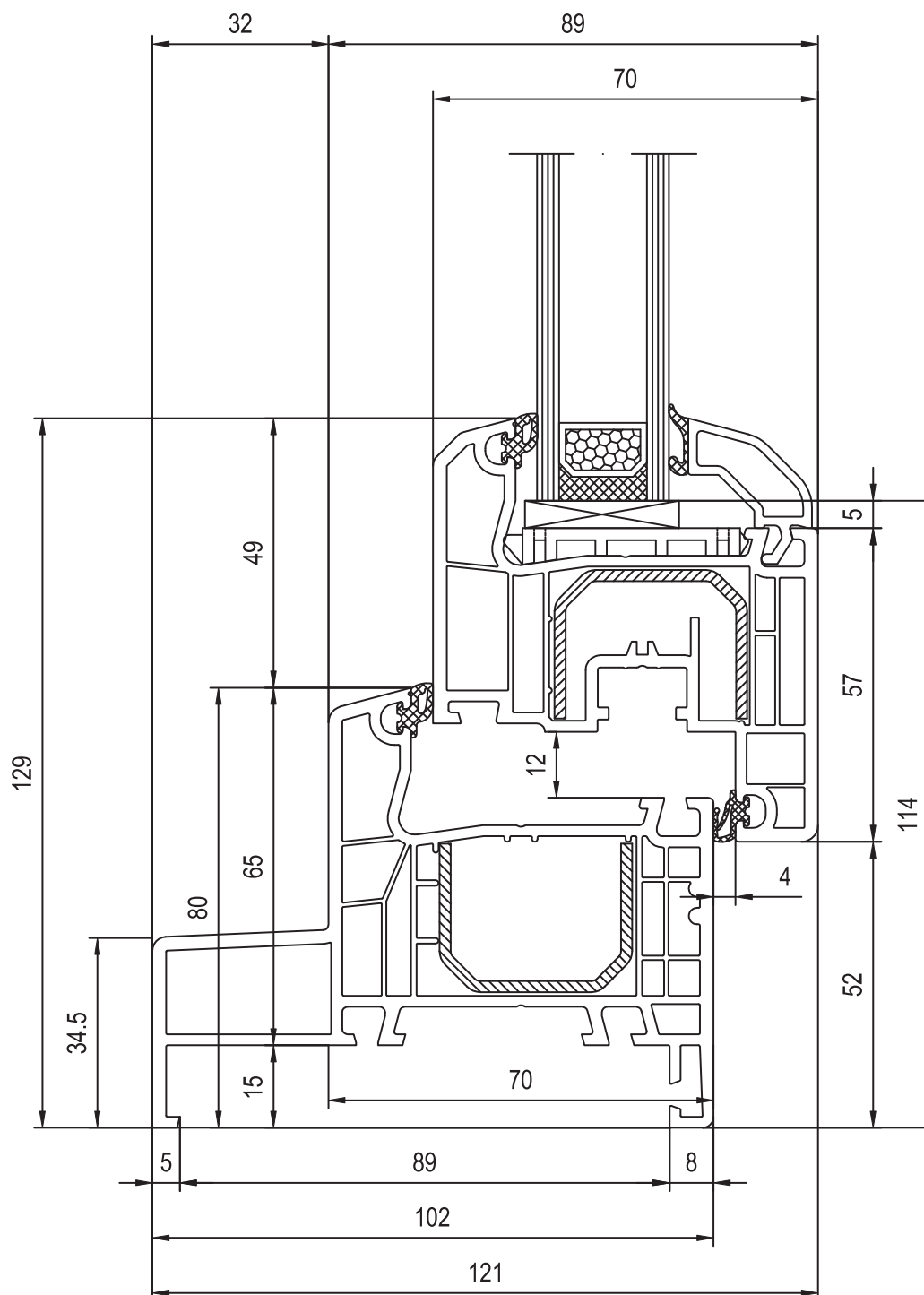

MONOBLOCK - Izolacja 100, Soft-line



MONOBLOC - Isolation 100, Soft-line



MONOBLOK - Isolatje 100, Soft-line



MONOBLOCK - Isolierung 100, Soft-line



MONOBLOCK - Isolamento 100, Soft-line



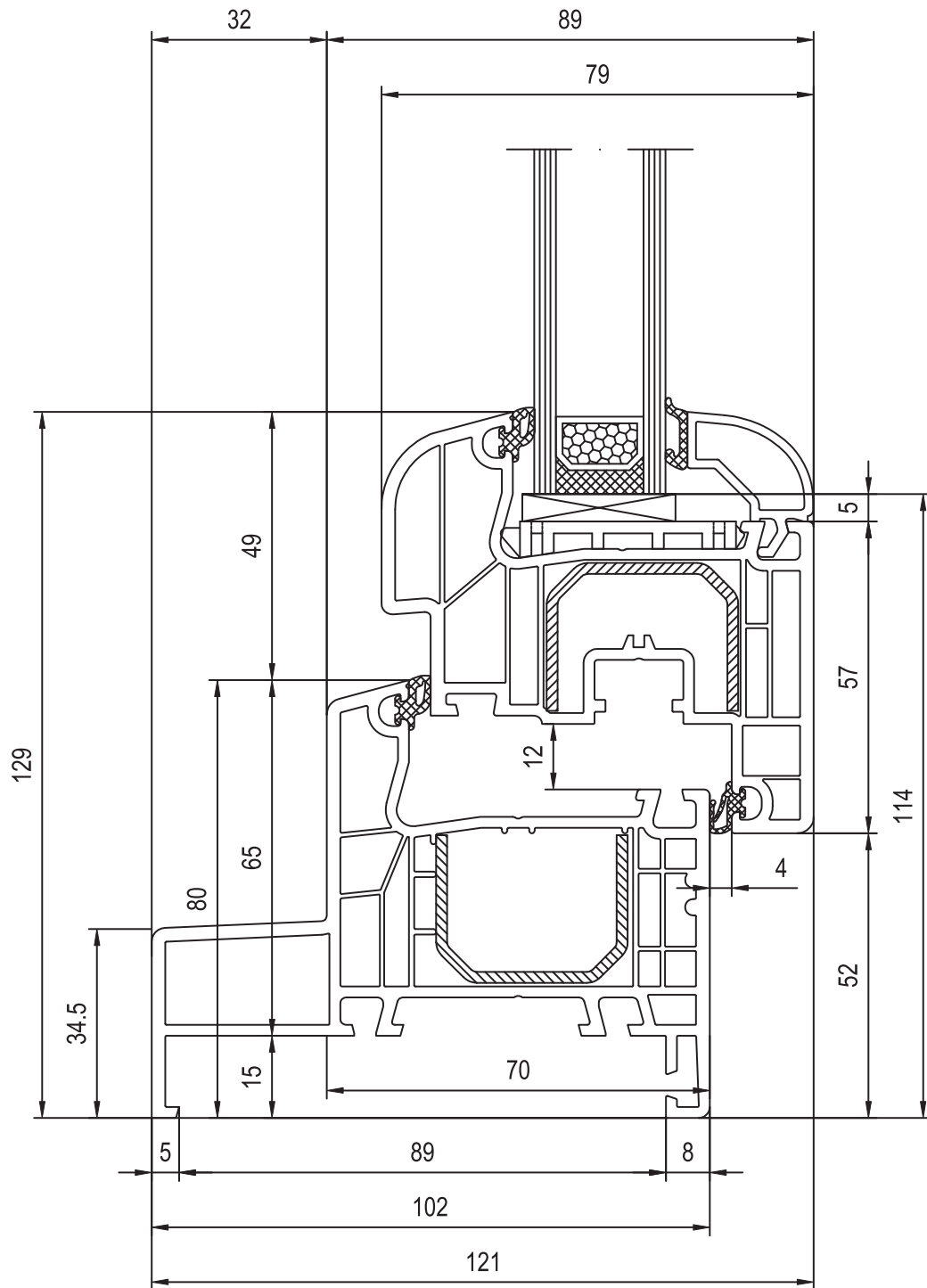
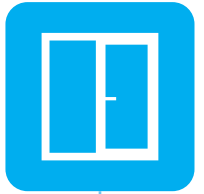

-  MONOBLOCK - Izolacja 100, Round-line
-  MONOBLOC - Isoation 100, Round-line
-  MONOBLOK - Isolatie 100, Round-line
-  MONOBLOCK - Isolierung 100, Round-line
-  MONOBLOCK - Isolamento 100, Round-line

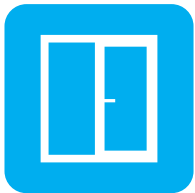

IDEAL 4000

140x16 - 140x20

**OKO
OKNA**

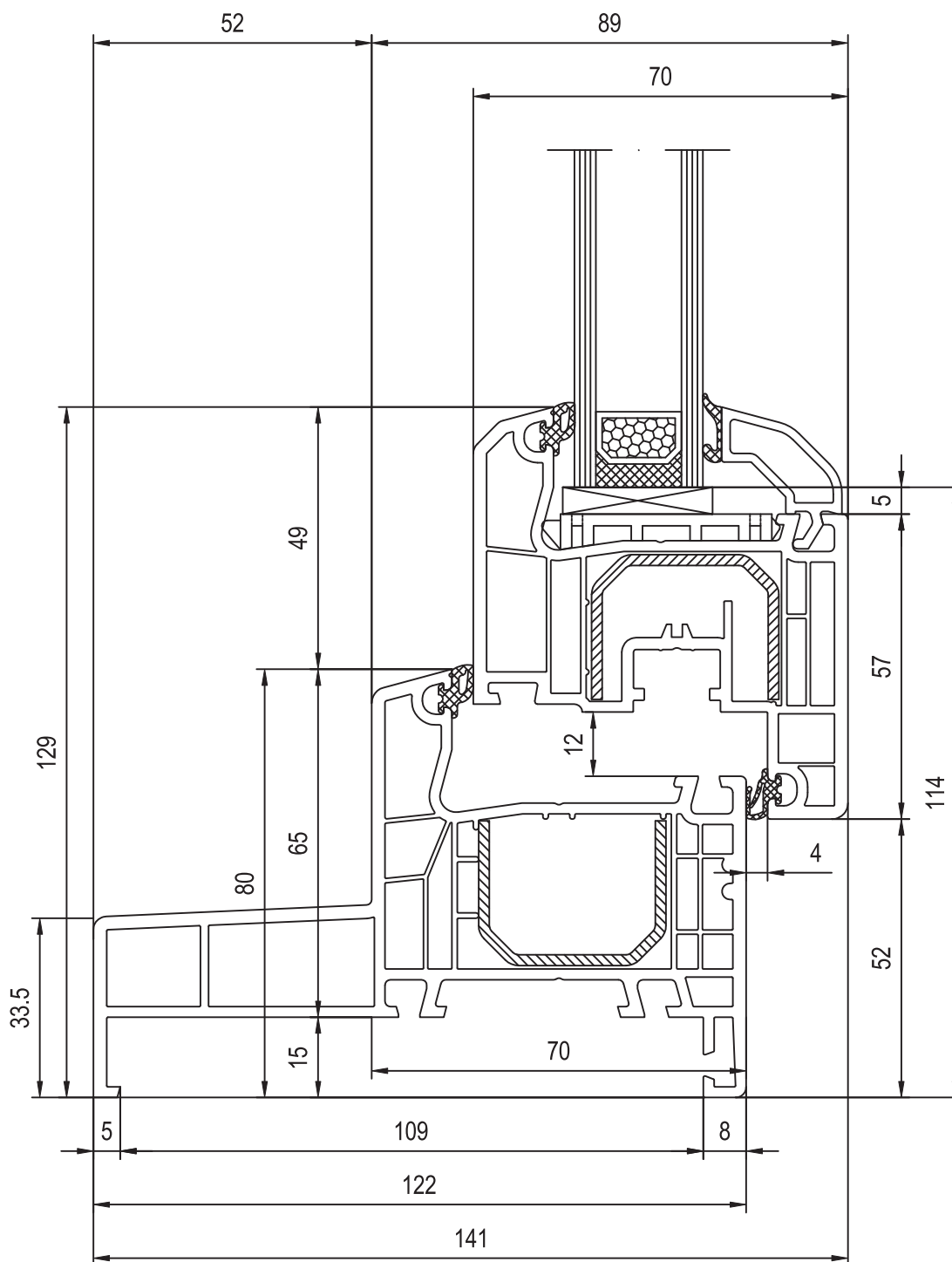

MONOBLOCK - Izolacja 120, Soft-line



MONOBLOC - Isolation 120, Soft-line



MONOBLOK - Isolatje 120, Soft-line



MONOBLOCK - Isolierung 120, Soft-line



MONOBLOCK - Isolamento 120, Soft-line



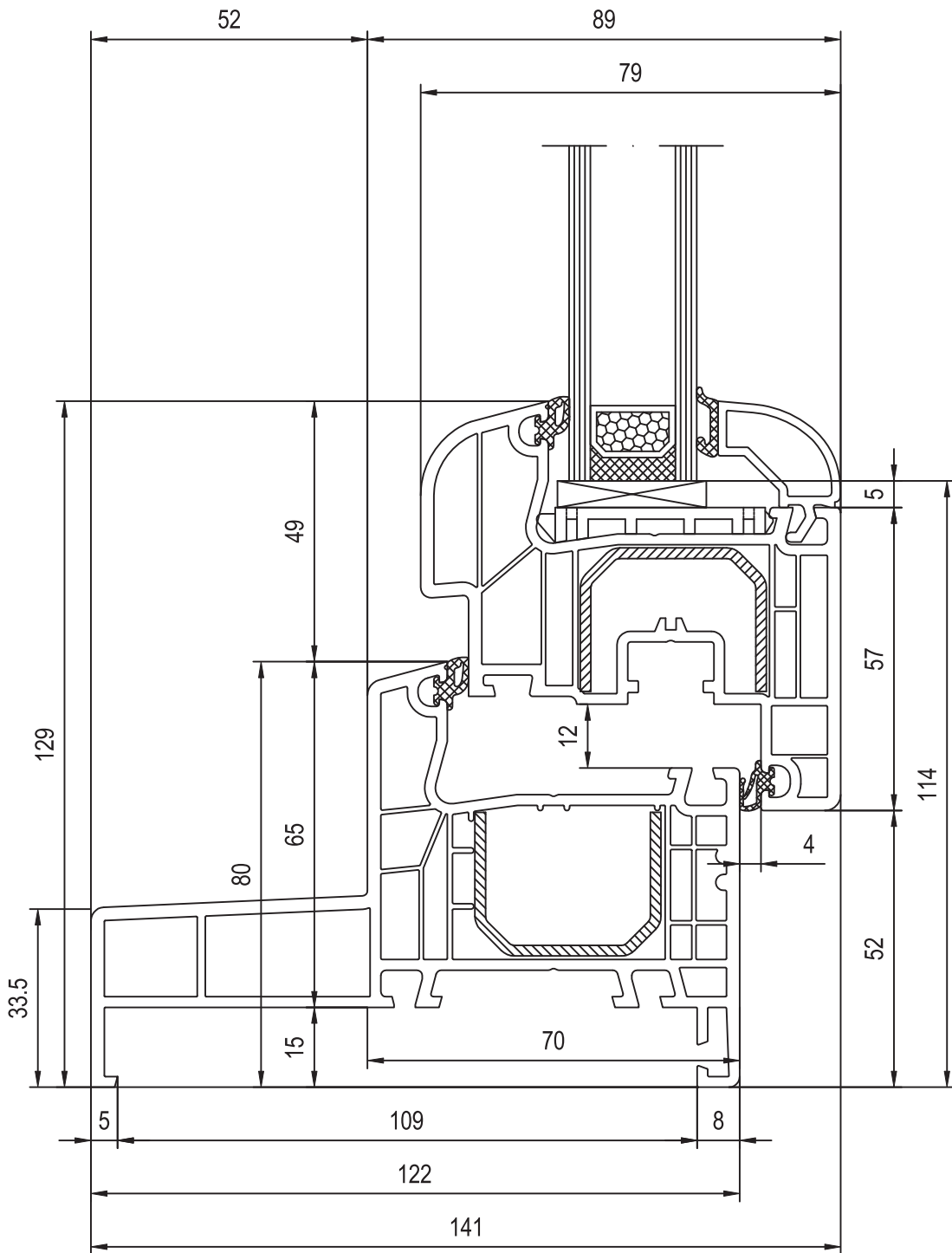

-  MONOBLOCK - Izolacja 120, Round-line
-  MONOBLOC - Isolation 120, Round-line
-  MONOBLOK - Isolatie 120, Round-line
-  MONOBLOCK - Isolierung 120, Round-line
-  MONOBLOCK - Isolamento 120, Round-line

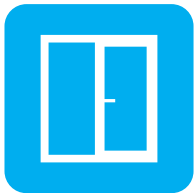

IDEAL 4000

140x18 - 140x20

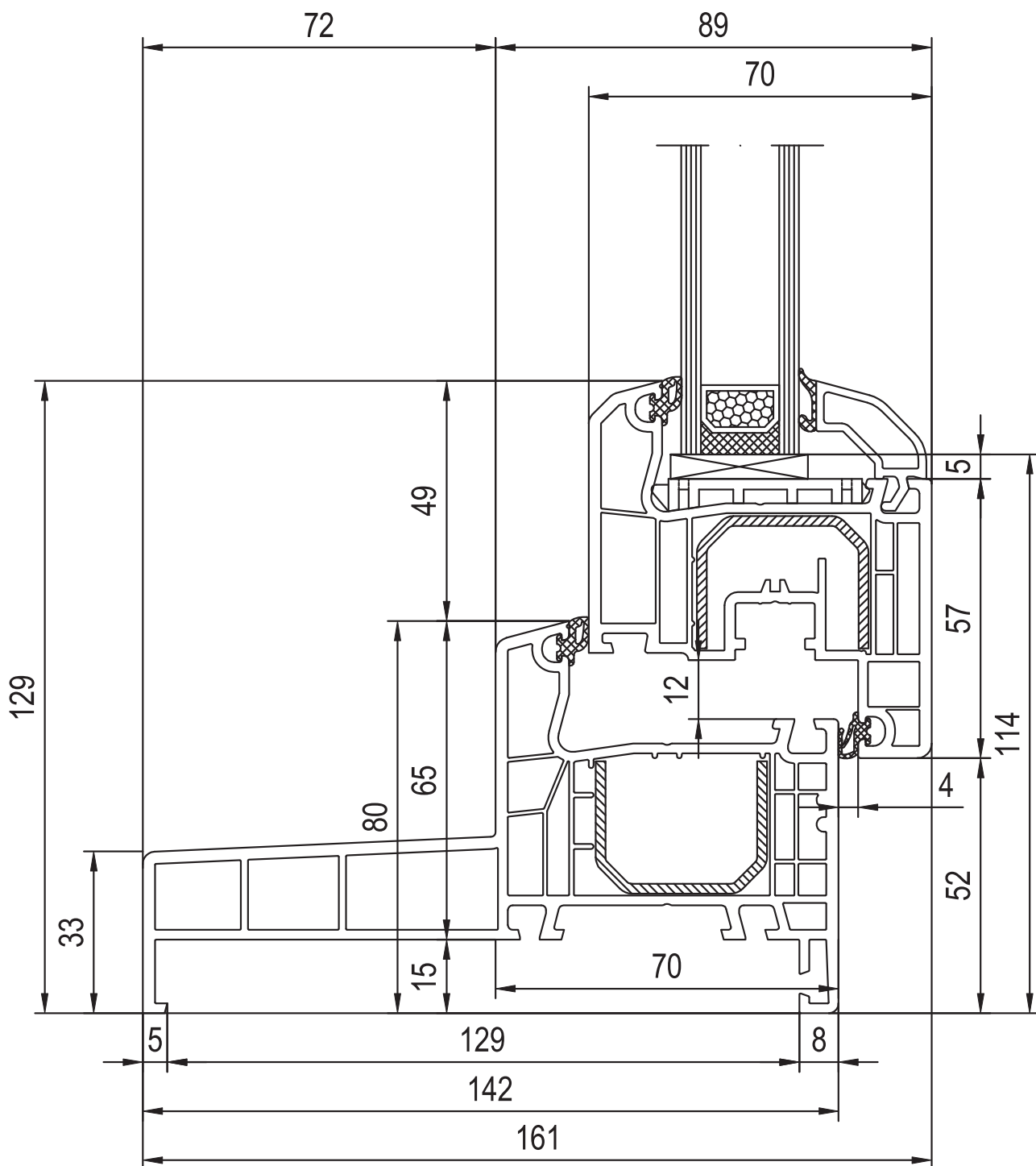

MONOBLOCK - Izolacja 140, Soft-line



MONOBLOC - Isoation 140, Soft-line



MONOBLOK - Isolatie 140, Soft-line



MONOBLOCK - Isolierung 140, Soft-line



MONOBLOCK - Isolamento 140, Soft-line



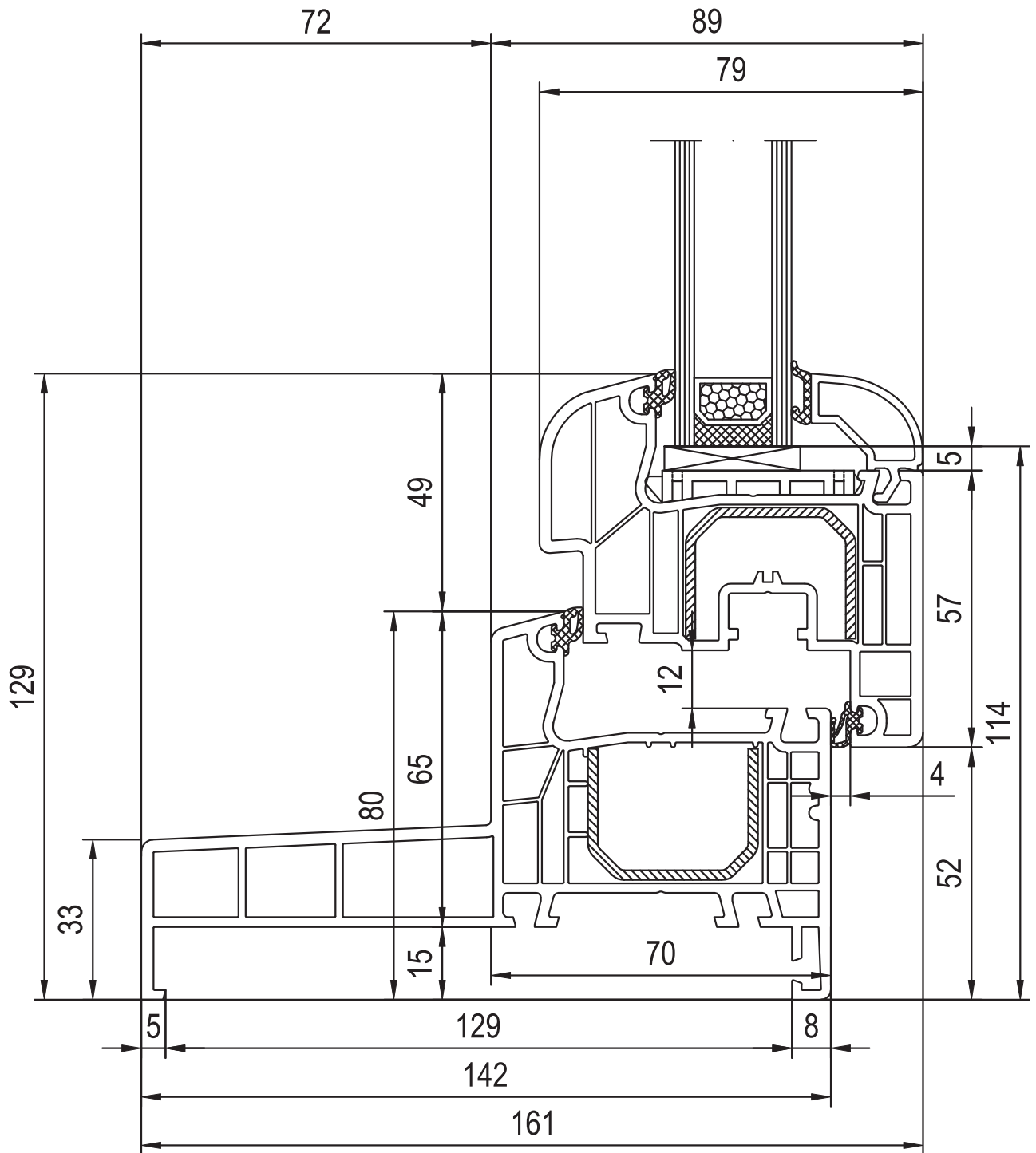

-  MONOBLOCK - Izolacja 140, Round-line
-  MONOBLOC - Isolation 140, Round-line
-  MONOBLOK - Isolatie 140, Round-line
-  MONOBLOCK - Isolierung 140, Round-line
-  MONOBLOCK - Isolamento 140, Round-line

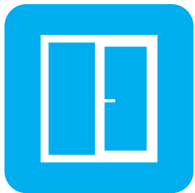

IDEAL 4000

140x19 - 140x20

**OKO
OKNA**

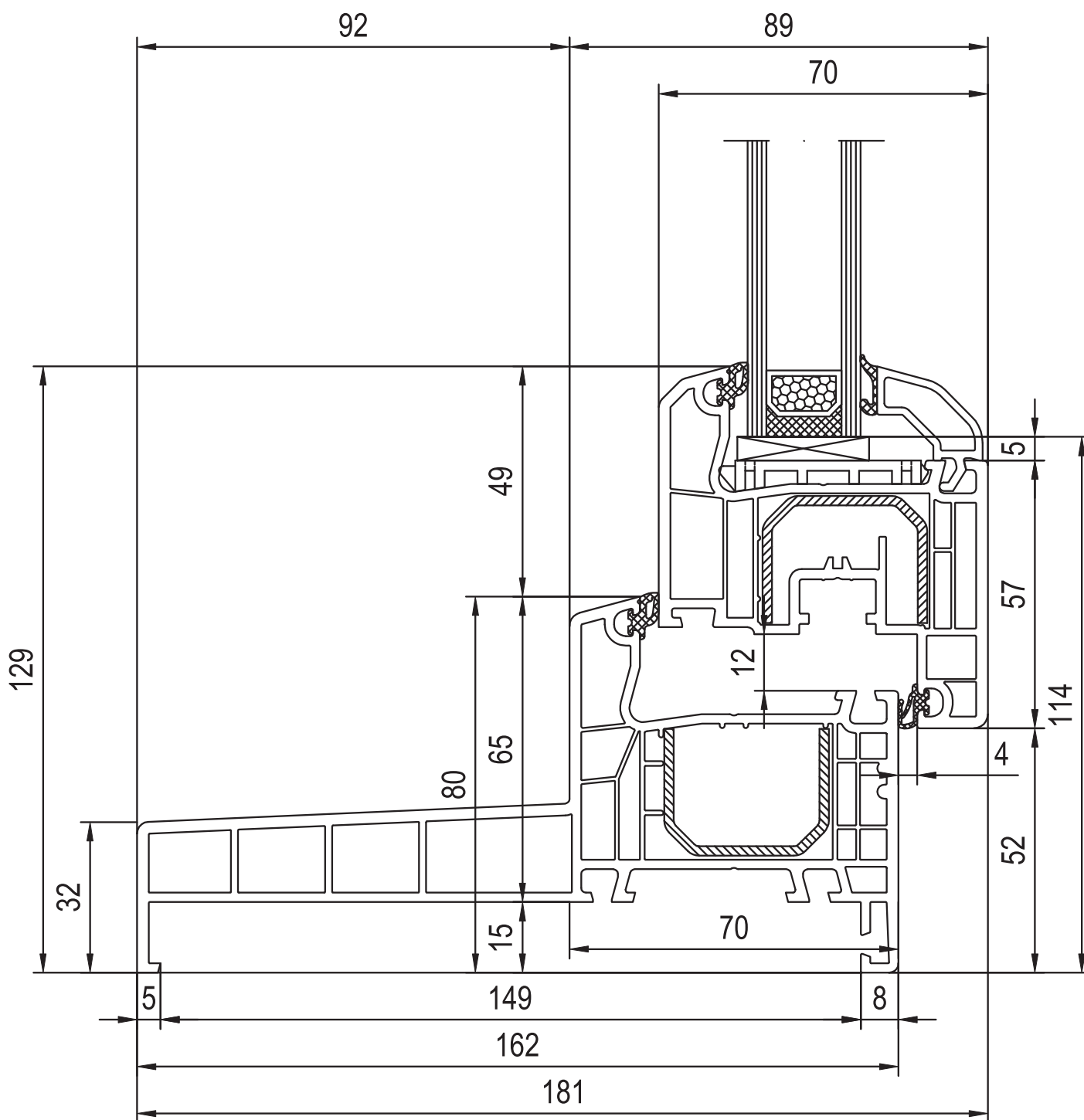

MONOBLOCK - Izolacja 160, Soft-line



MONOBLOC - Isoation 160, Soft-line



MONOBLOK - Isolatje 160, Soft-line



MONOBLOCK - Isolierung 160, Soft-line







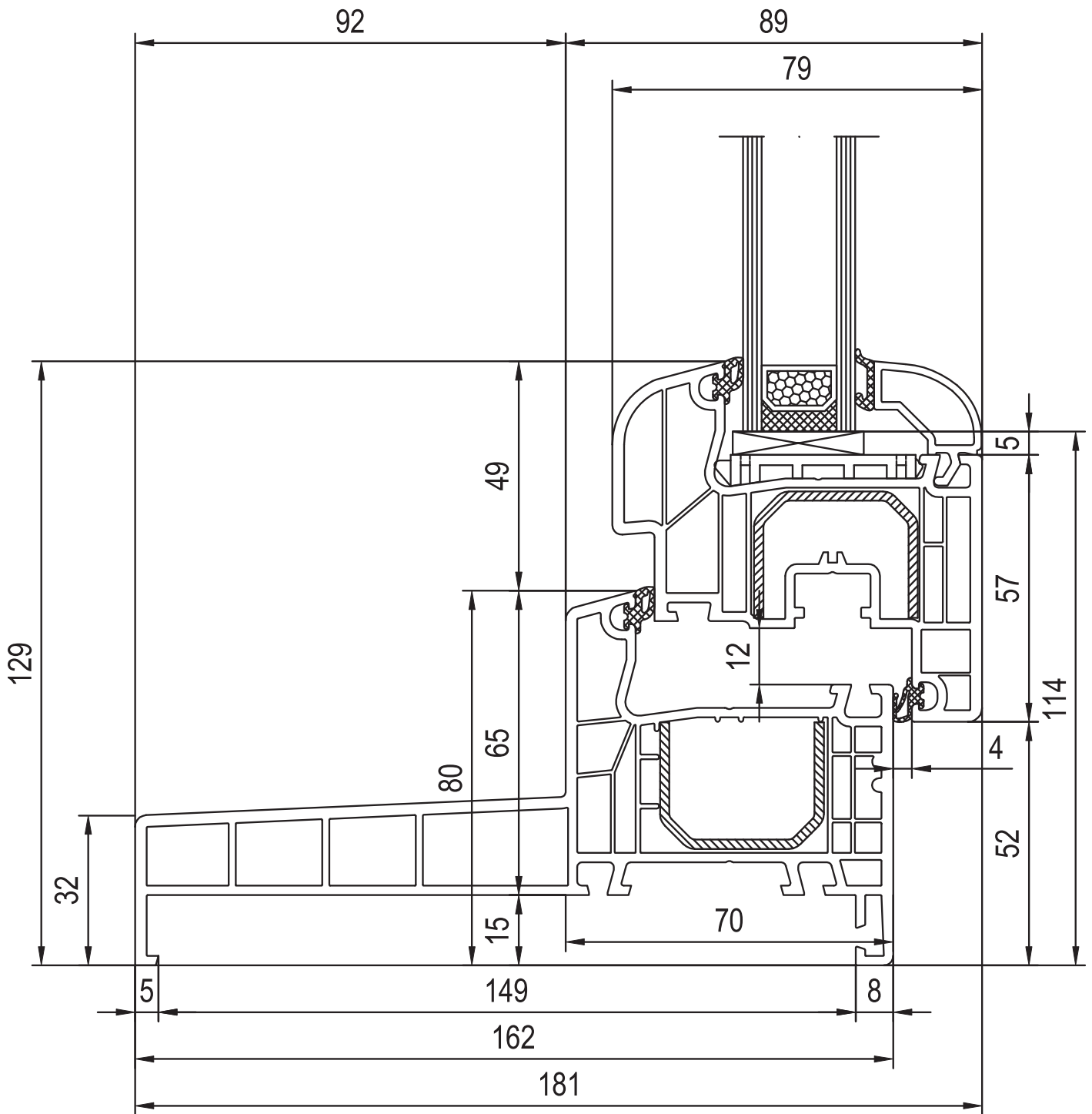
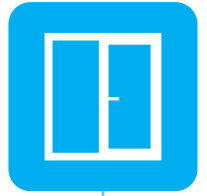

MONOBLOCK - Isolamento 160, Soft-line

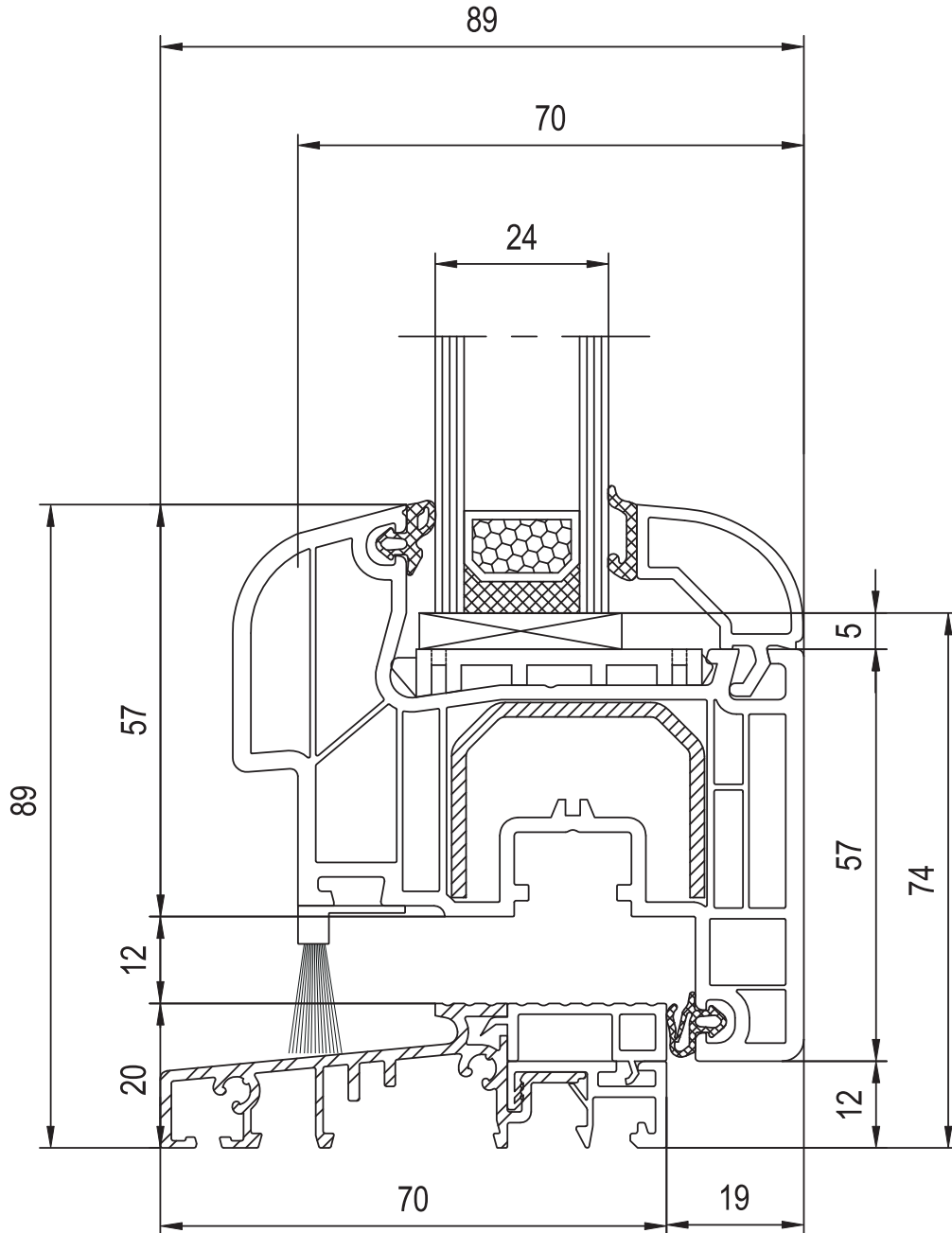



-  MONOBLOCK - Izolacja 160, Round-line
-  MONOBLOC - Isolation 160, Round-line
-  MONOBLOK - Isolatie 160, Round-line
-  MONOBLOCK - Isolierung 160, Round-line
-  MONOBLOCK - Isolamento 160, Round-line



-  Skrzydło okienne z progiem, Round-line
-  Porte-fenêtre avec seuil plat 20 mm, Round-line
-  Balkon raam met drempel, Round-line
-  Balkontür mit Schwelle, Round-line
-  Portafinestra con soglia, Round-line



IDEAL 4000

140x30 - 249060

eko
okna

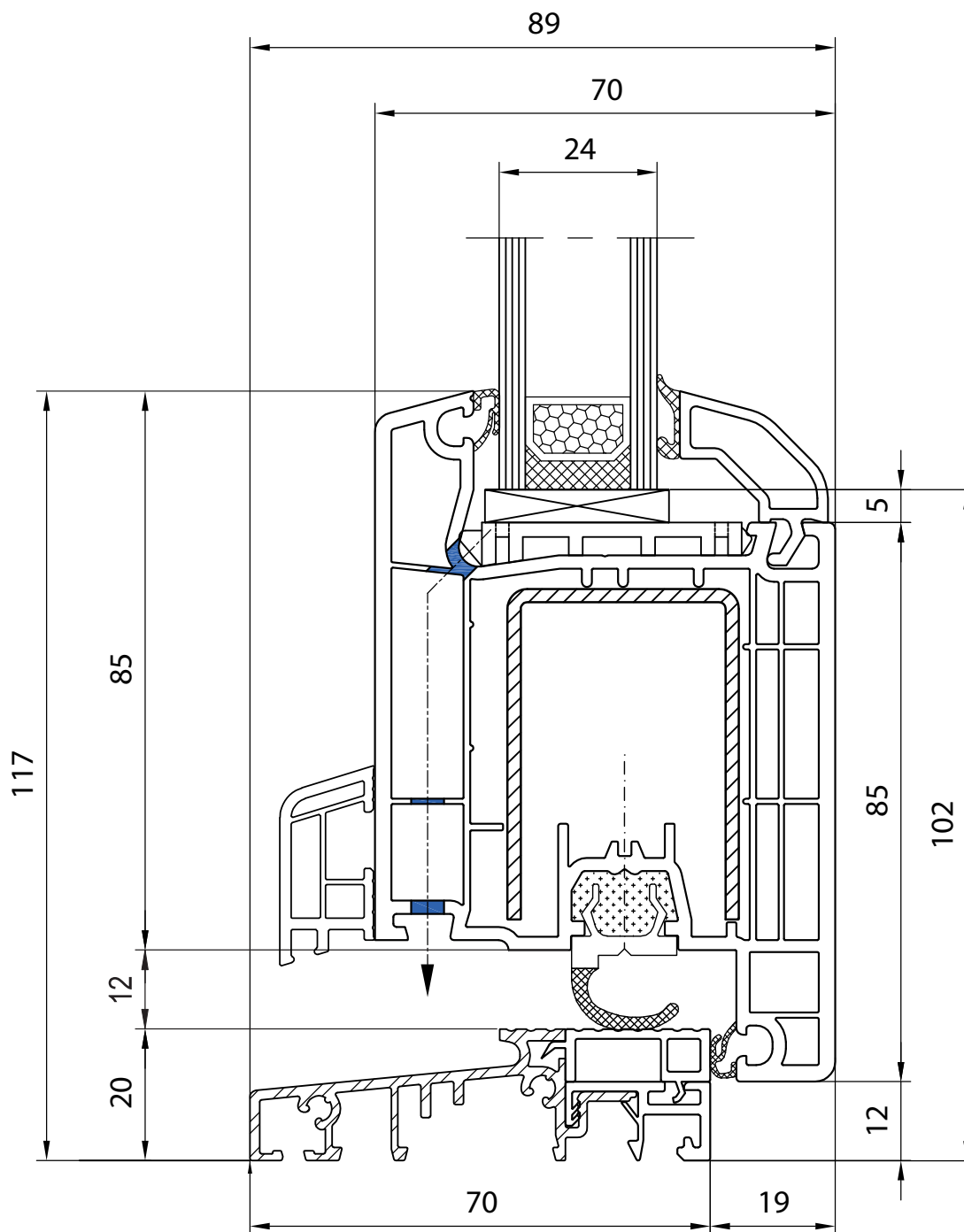

Skrzydło drzwiowe tarasowe z progim, otwierane do wewnątrz

Profil de passage avec seuil plat 20 mm, ouverture vers l'intérieur





Terras profiel met drempel, naar binnen opendraaiend

Terassentür mit Schwelle, nach Innen öffnend

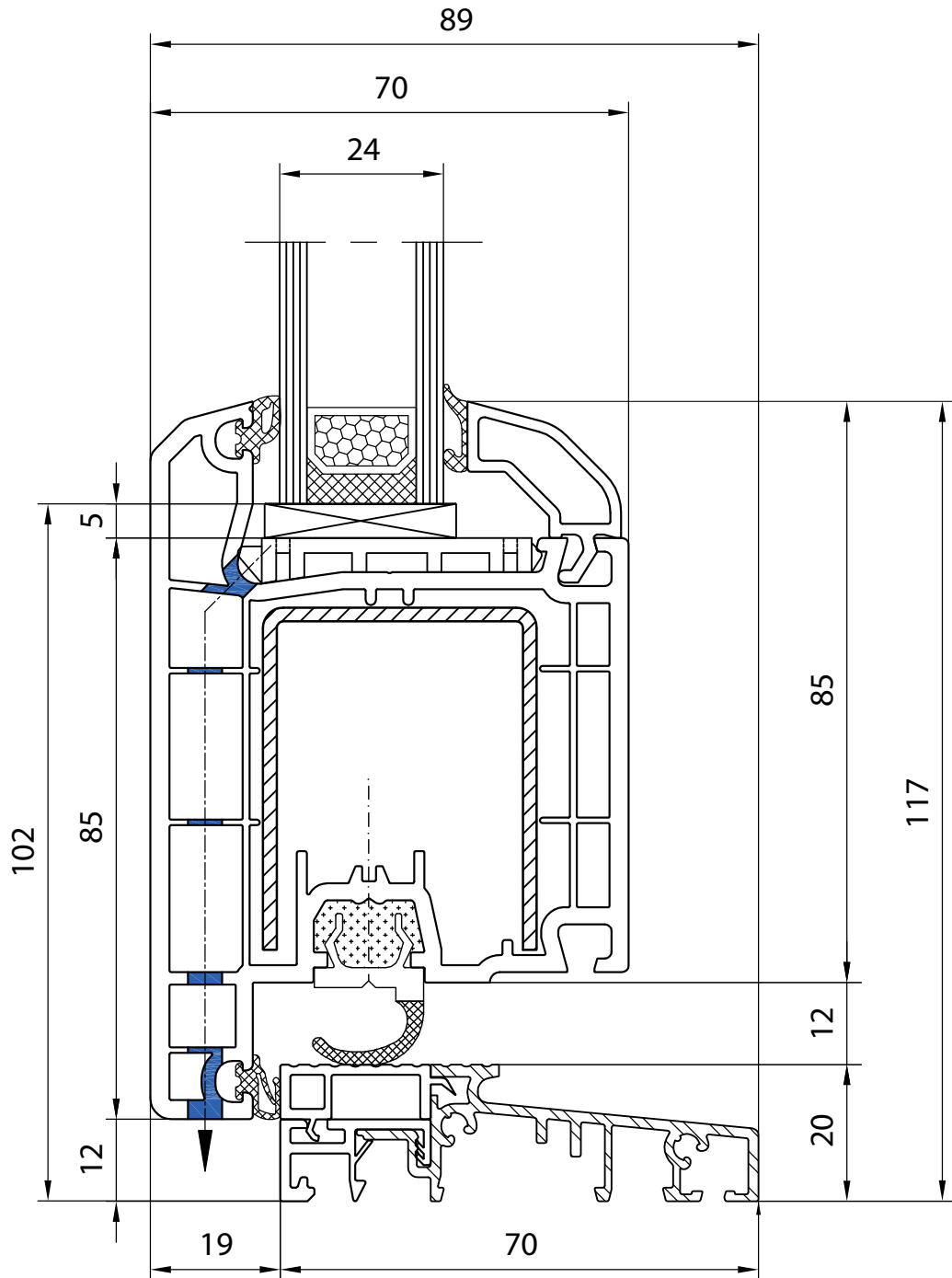
Portaveranda con soglia, l'apertura verso interno





-  Skrzydło drzwiowe tarasowe z progiem, otwierane na zewnątrz
-  Profil de passage avec seuil plat 20 mm, ouverture vers l'extérieur
-  Terras profiel met drempel, naar buiten opendraaiend
-  Terrassentür mit Schwelle, nach Aussen öffnend
-  Portaveranda con soglia, l'apertura verso esterno



IDEAL 4000

140x33 - 249060

**OKO
OKNA**

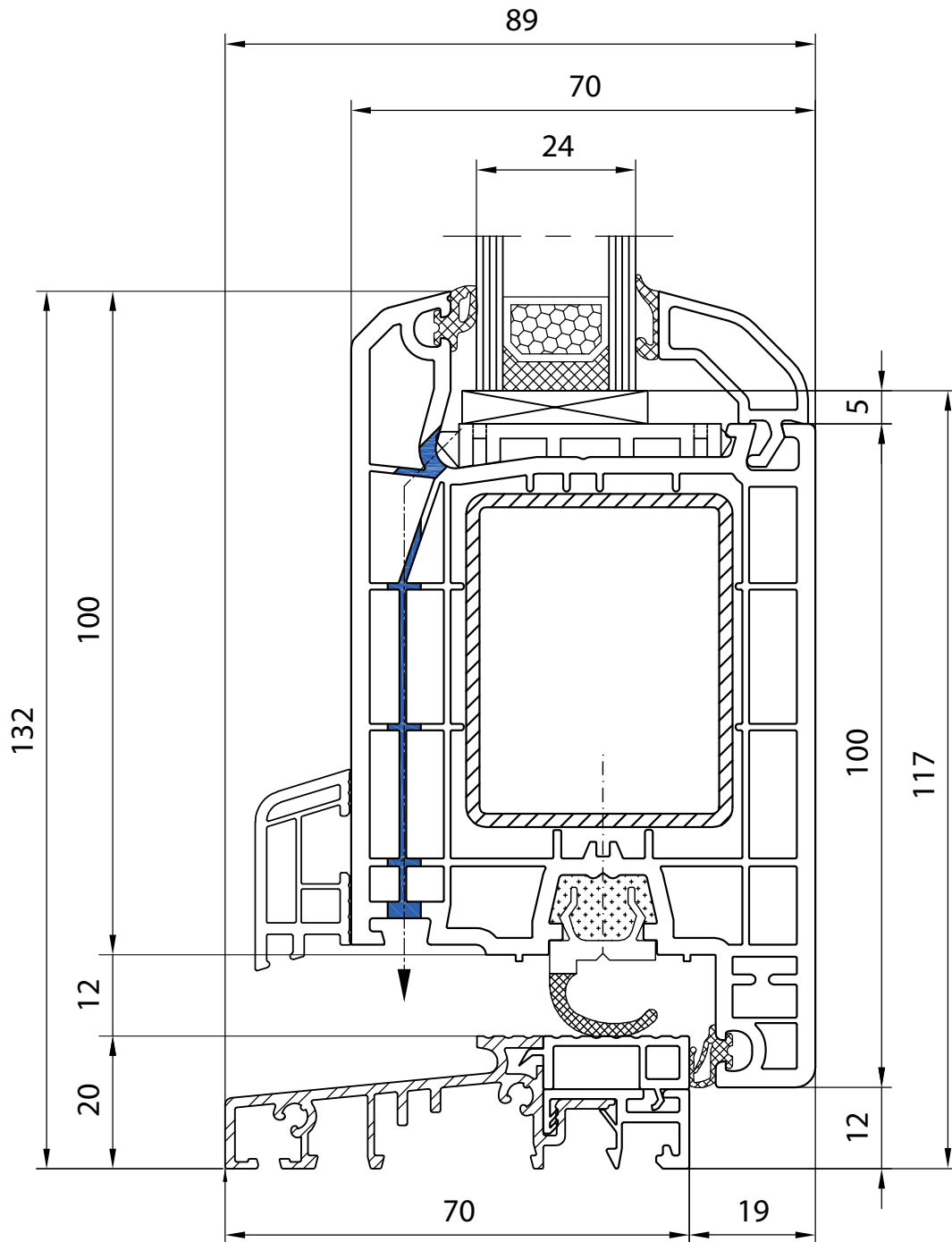

Dolny przekrój, drzwi wejściowe typu A, otwierane do wewnątrz

Coupe du bas, porte d'entrée type A, ouverture vers l'intérieur





Onderste doorsnede, deur versie A, naar binnen opendraaien

Unterer Querschnitt, eingangstür Version „A“, nach Innen öffnend

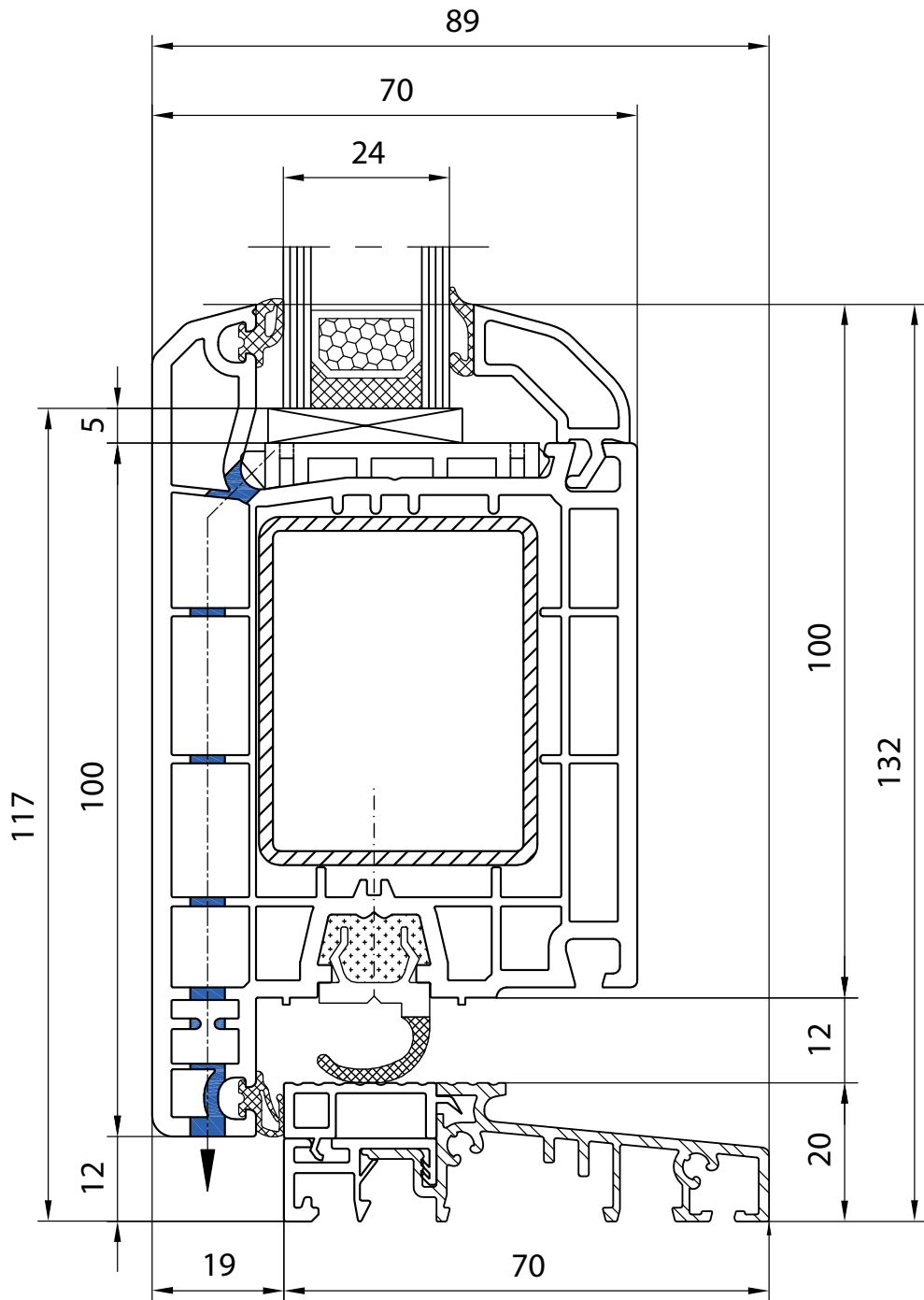
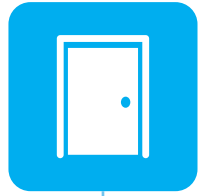
Sezione inferiore, porta d'ingresso la versione „A“, l'apertura verso interno





-  Dolny przekrój, drzwi wejściowe typu A, otwierane na zewnątrz
-  Coupe du bas, porte d'entrée type A, ouverture vers l'extérieur
-  Onderste doorsnede, deur versie A, naar buiten opendraaiend
-  Unterer Querschnitt, eingangstür Version „A“, nach Aussen öffnend
-  Sezione inferiore, porta d'ingresso la versione „A“, l'apertura verso esterno



IDEAL 4000

140x20 - 140x41 - 140x20

**eko
okna**

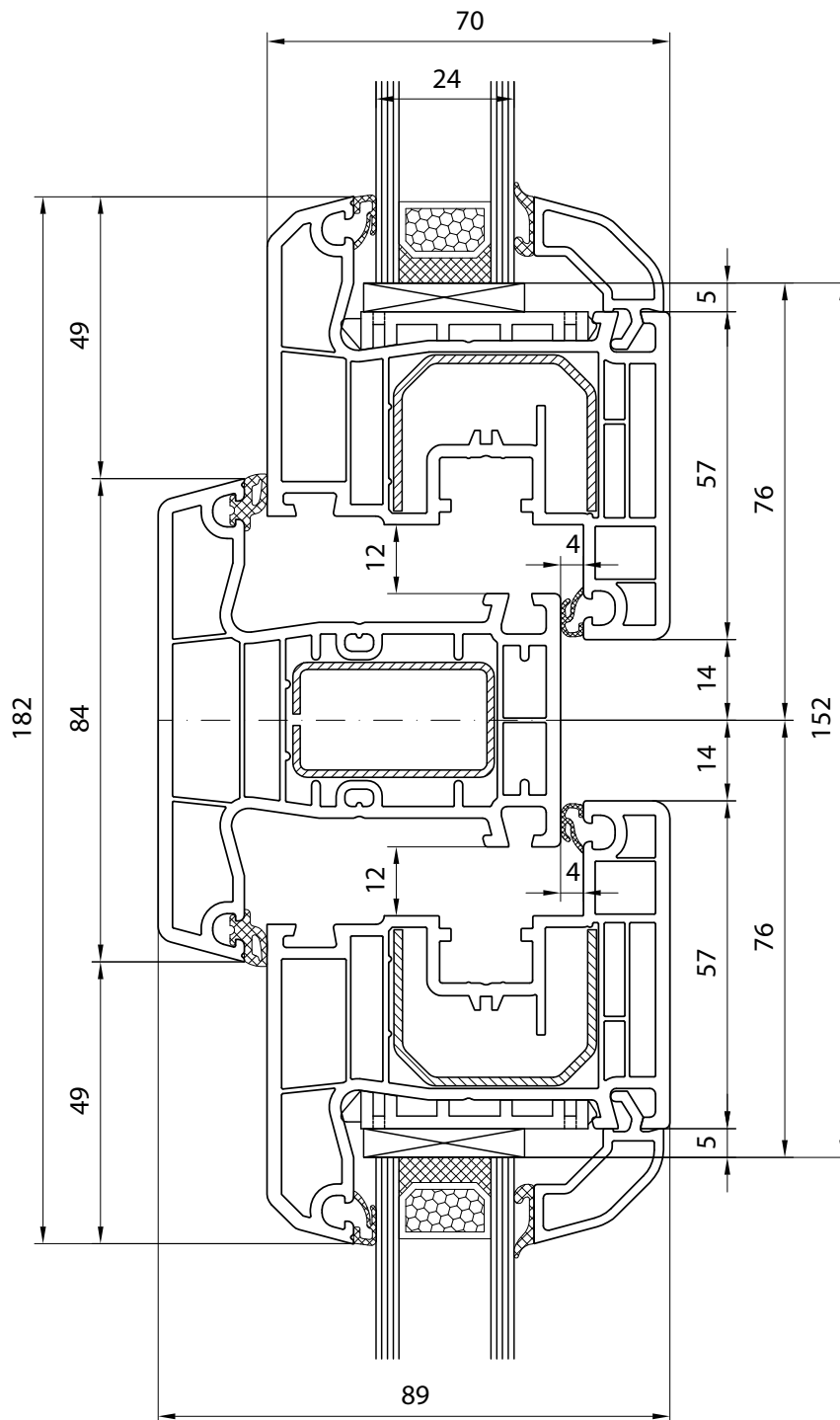

Przekrój przez słupek stały (standard 84 mm) z dwoma skrzydłami, Soft-line

Coupe meneau fixe (standard de 84 mm) avec deux ouvrants, Soft-line





Doorsnede, vaste stijl (std 84 mm) met twee vleugels, Soft-line

Längsschnitt fester Pfosten (std 84 mm) mit zwei Flügel, Soft-line

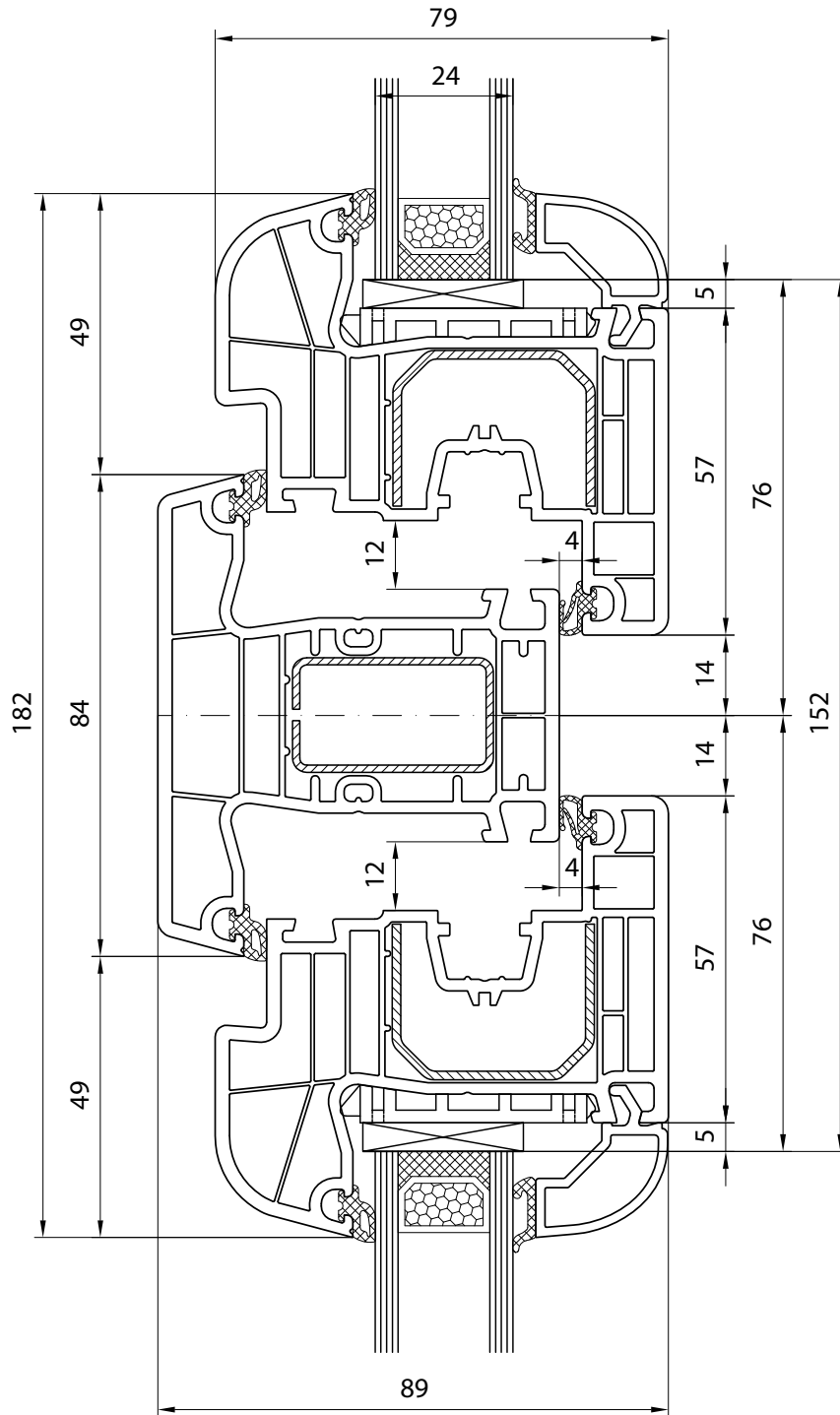
Sezione del montante fisso (standard 84 mm) con due ante, Soft-line





-  Przekrój przez słupek stały (standard 84 mm) z dwoma skrzydłami, Round-line
-  Coupe meneau fixe (standard de 84 mm) avec deux ouvrants, Round-line
-  Doorsnede, vaste stijl (std 84 mm) met twee vleugels, Round-line
-  Längsschnitt Fenster Pfosten (std 84 mm) mit zwei Flügeln, Round-line
-  Sezione del montante fisso (standard 84 mm) con due ante, Round-line



IDEAL 4000

140x30 - 140x41 - 140x30

**OKO
OKNA**

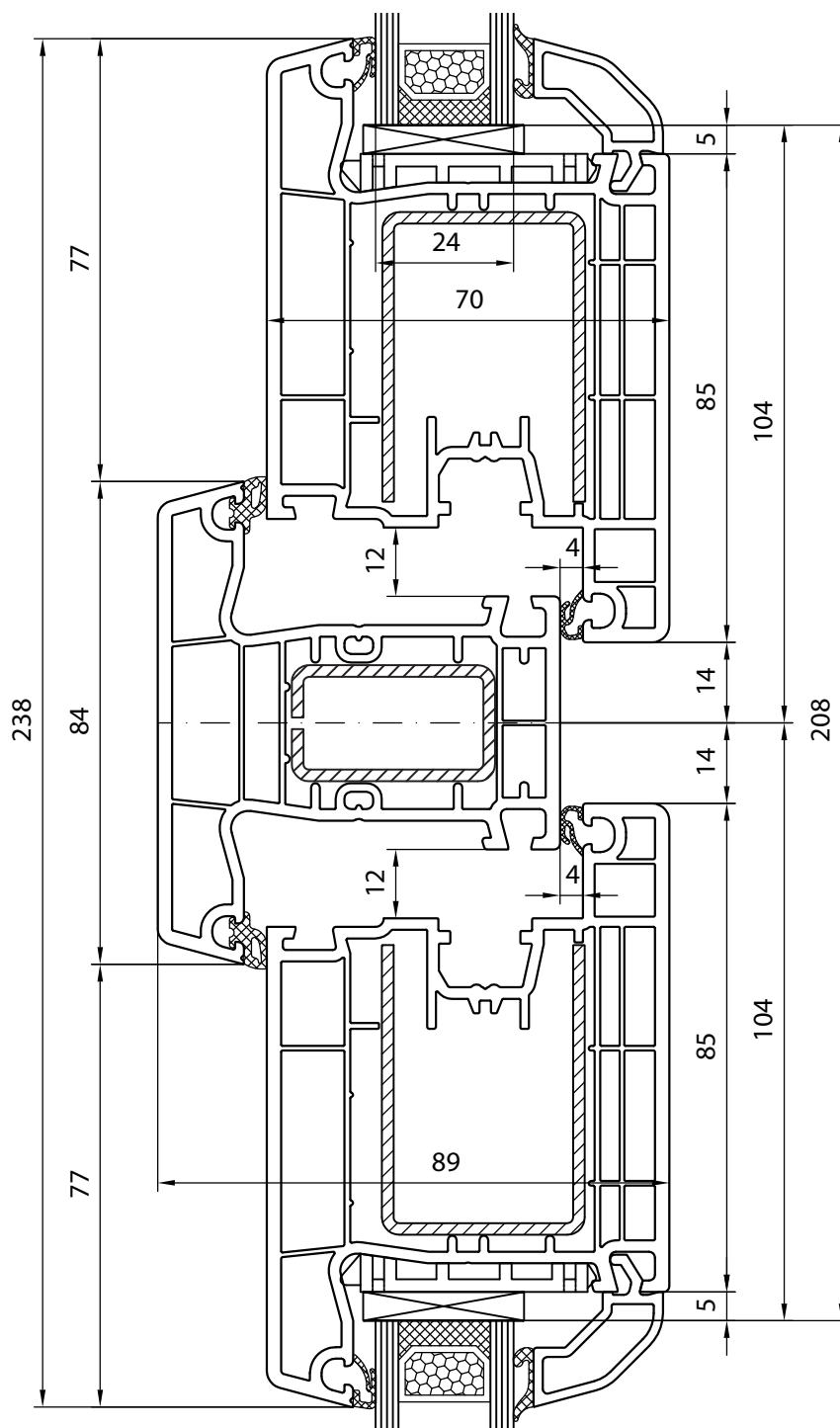

Przekrój przez słupek stały 84 mm z dwoma skrzydłami tarasowymi, otwierany do wewnątrz

Coupe profil de passage, deux ouvrants, ouverture vers l'intérieur avec meneau fixe de 84 mm

Doorsnede terras profiel, twee vleugels naar binnen opendraaiend met vaste stijl 84 mm

Längsschnitt Terrassentür mit zwei Flügeln, nach Innen öffnend mit festem Pfahl 84 mm

Sezione della portaveranda a due ante, l'apertura verso interno con montante fisso 84 mm



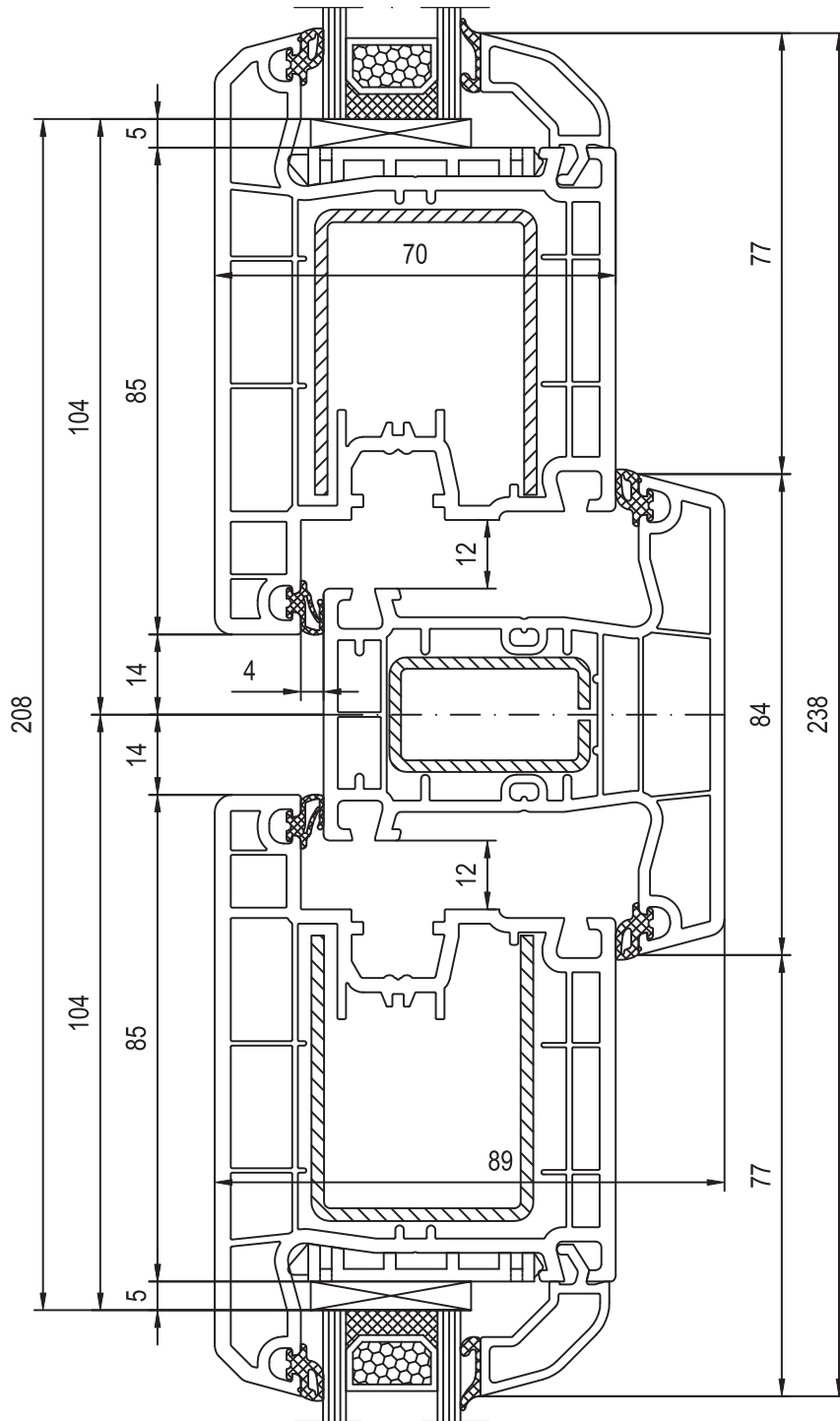

Przekrój przez słupek stały 84 mm z dwoma skrzydłami tarasowymi, otwierany na zewnątrz



Coupe profil de passage, deux ouvrants, ouverture vers l'extérieur avec meneau fixe de 84 mm



Doorsnede terras profiel, twee vleugels naar buiten opendraaiend met vaste stijl 84 mm



Querschnitt Terrassentür mit zwei Flügeln, nach Aussen öffnend mit festem Pfahl 84 mm



Sezione della portaveranda a due ante, l'apertura verso esterno con montante fisso 84 mm



IDEAL 4000

140x33 - 140x41 - 140x33

**OKO
OKNA**

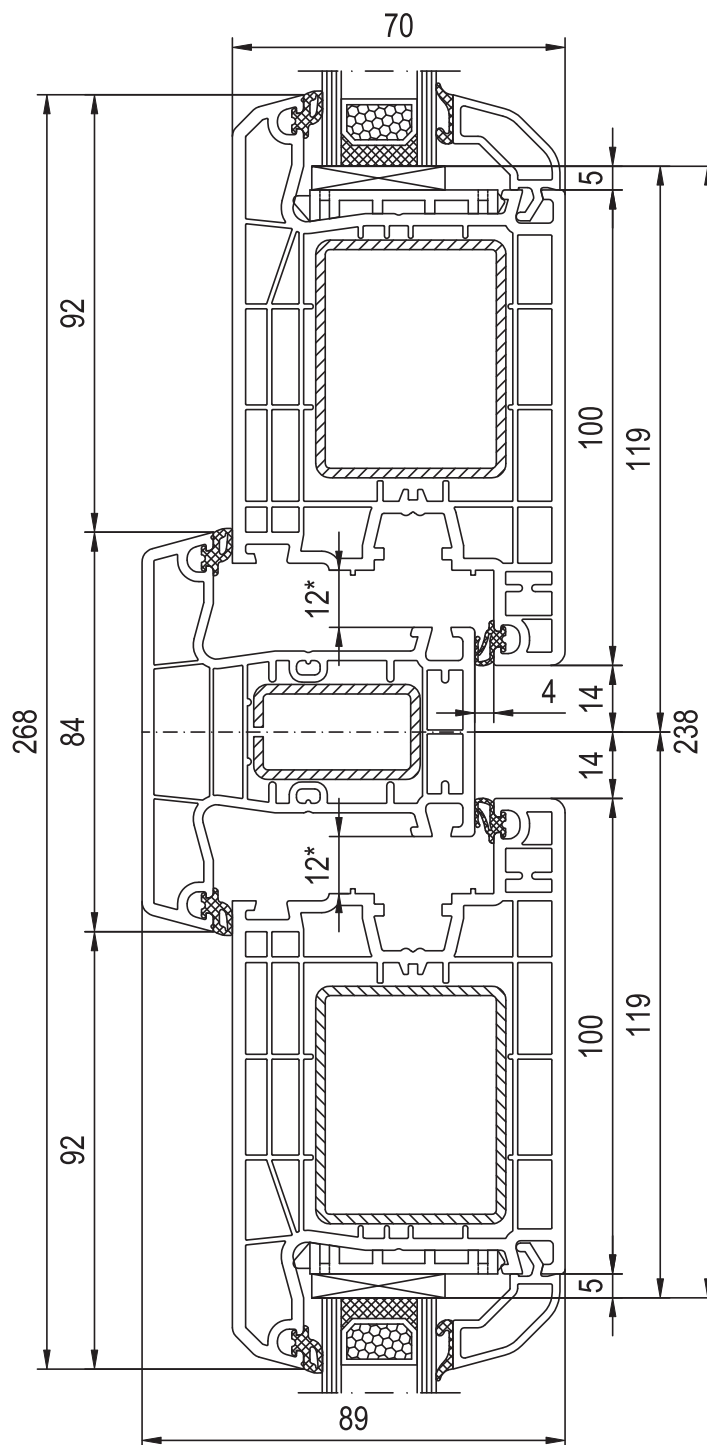

Dwa skrzydła drzwiowe ze słupkiem stałym 84 mm, otwierane do wewnątrz

Deux ouvrants de porte avec meneau fixe de 84 mm, ouverture vers l'intérieur





Twee deur vleugels met vaste stijl 84 mm, naar binnen opendraaiend

Zwei Türflügel mit festem Pfahl 84 mm, nach Innen öffnend

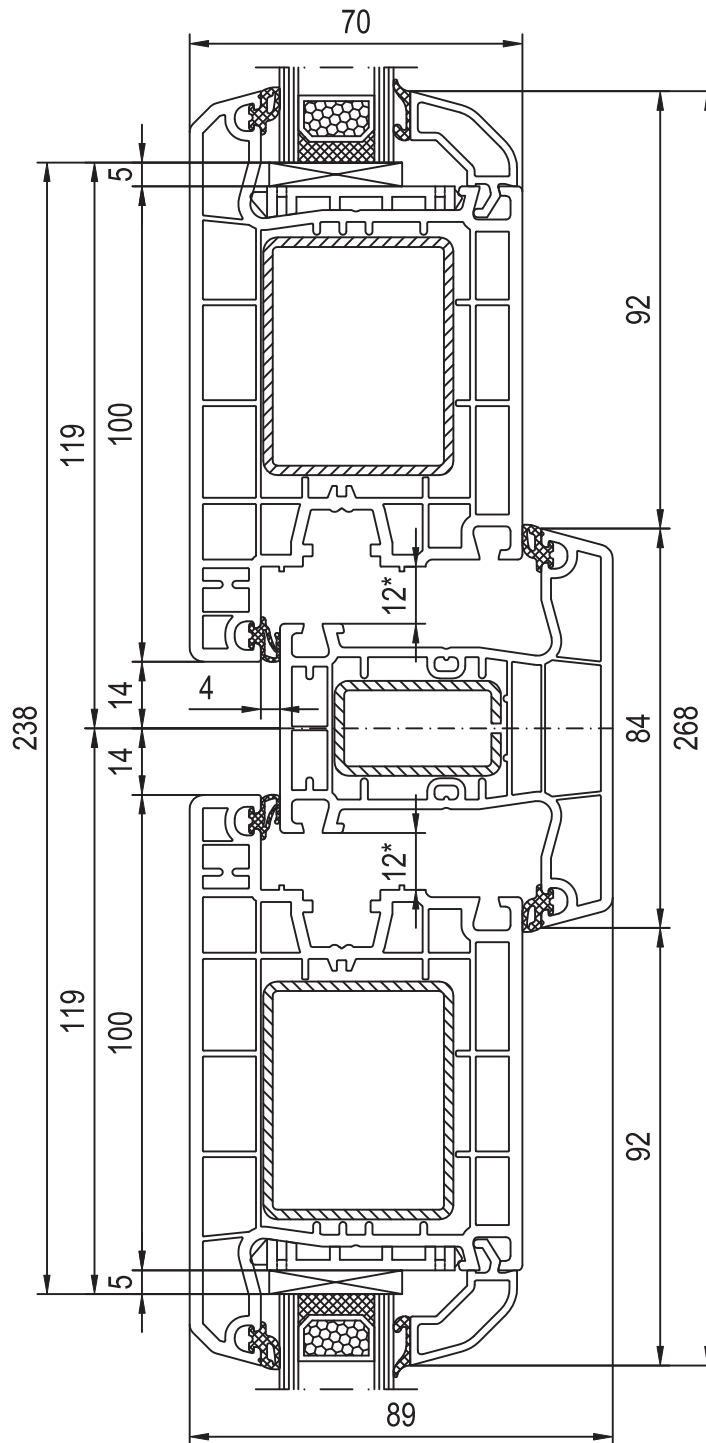
Porta a due ante con montante fisso 84 mm, l'apertura verso interno





-  Dwa skrzydła drzwiowe ze słupkiem stałym 84 mm, otwierane na zewnątrz
-  Deux ouvrants de porte avec meneau fixe de 84 mm, ouverture vers l'extérieur
-  Twee deur vleugels met vaste stijl 84 mm, naar buiten opendraaiend
-  Zwei Türflügel mit festem Pfahl 84 mm, nach Aussen öffnend
-  Porta a due ante con montante fisso 84 mm, l'apertura verso esterno

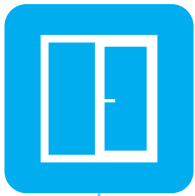

IDEAL 4000

140x41

**OKO
OKNA**

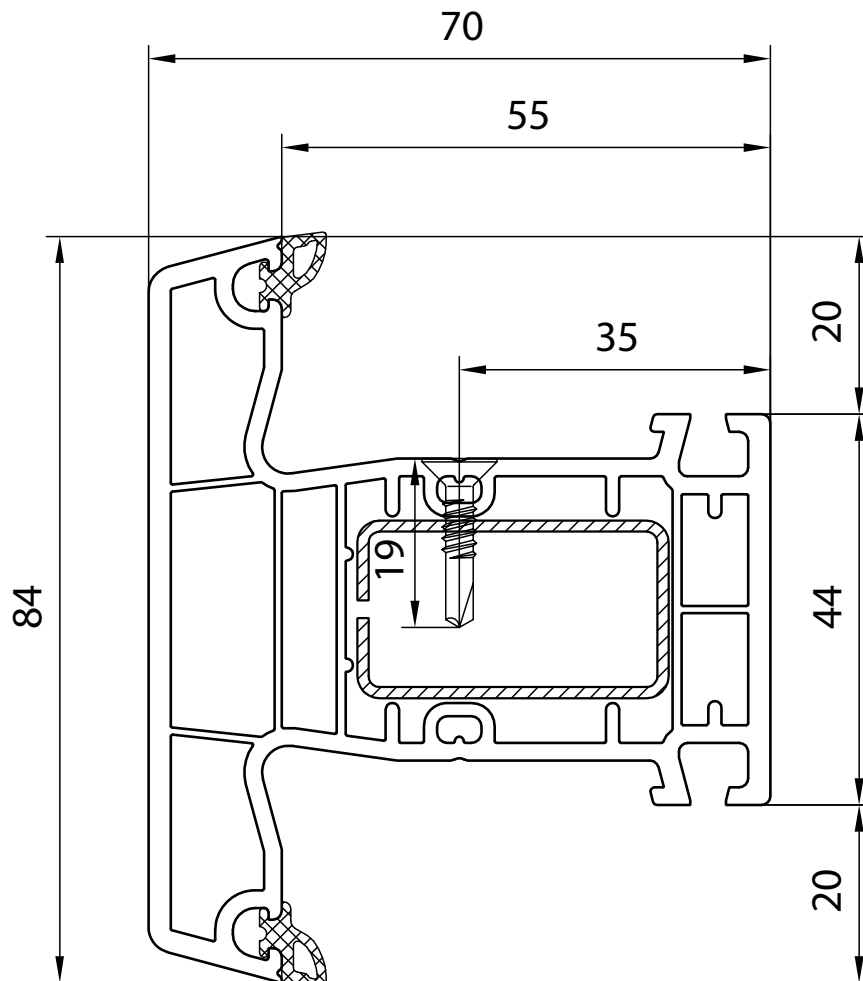

Standardowy słupek stały 84 mm



Meneau standard de 84 mm



Standaard stijl 84 mm









Fester Pfosten standard 84 mm

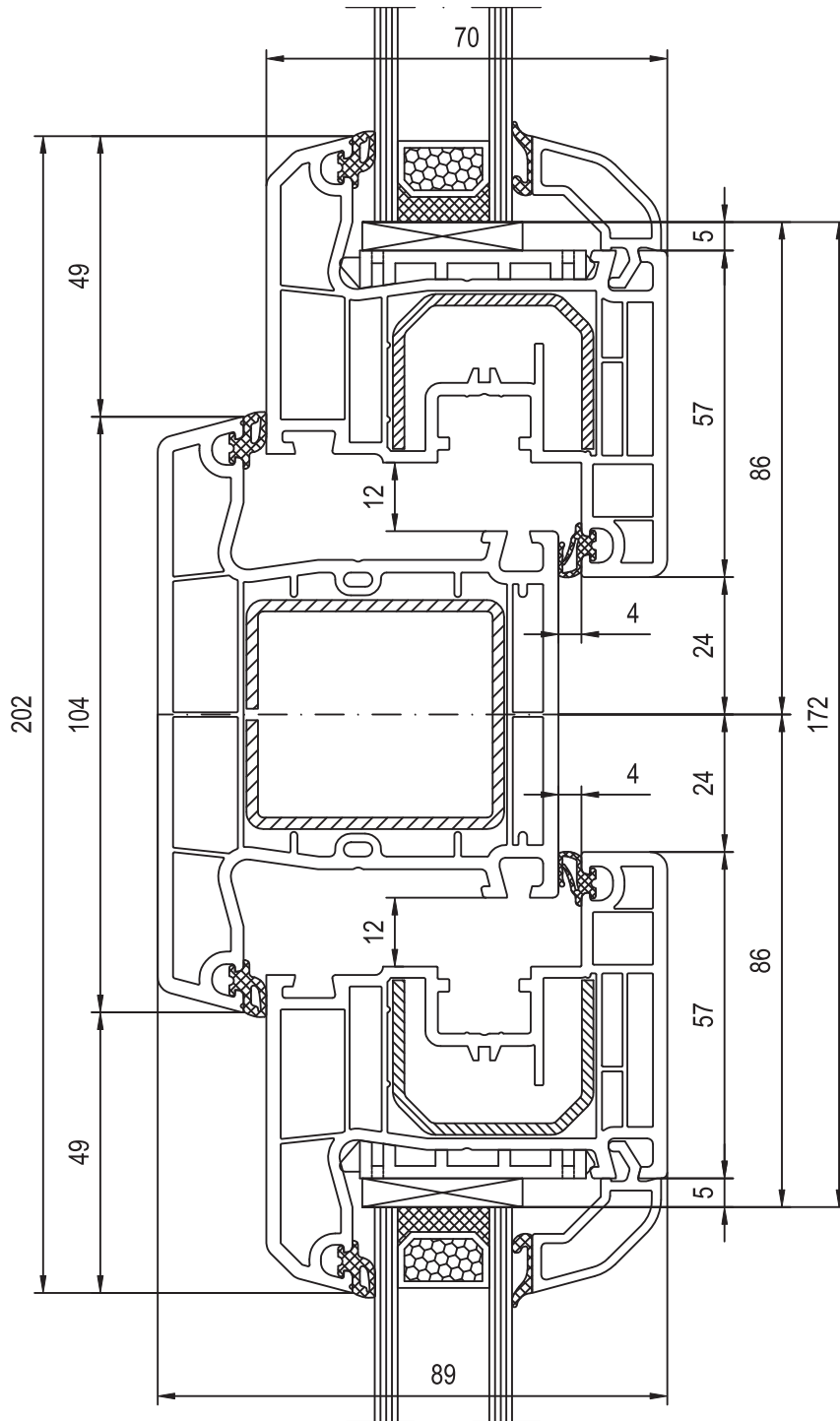

Montante standard 84 mm





-  Przekrój przez słupek stały 104 mm z dwoma skrzydłami, Soft-line
-  Coupe de deux ouvrants de fenêtre soft-line avec meneau large de 104 mm
-  Aansluiting van twee raam vleugels soft-line met brede stijl 104 mm
-  Verbunden mit Hilfe eines breiten Pfostens mit 104 mm Breite
-  Giunzione di due ante finestra soft-line con montante 104 mm



IDEAL 4000

140x22 - 140x45 - 140x22

**OKO
OKNA**

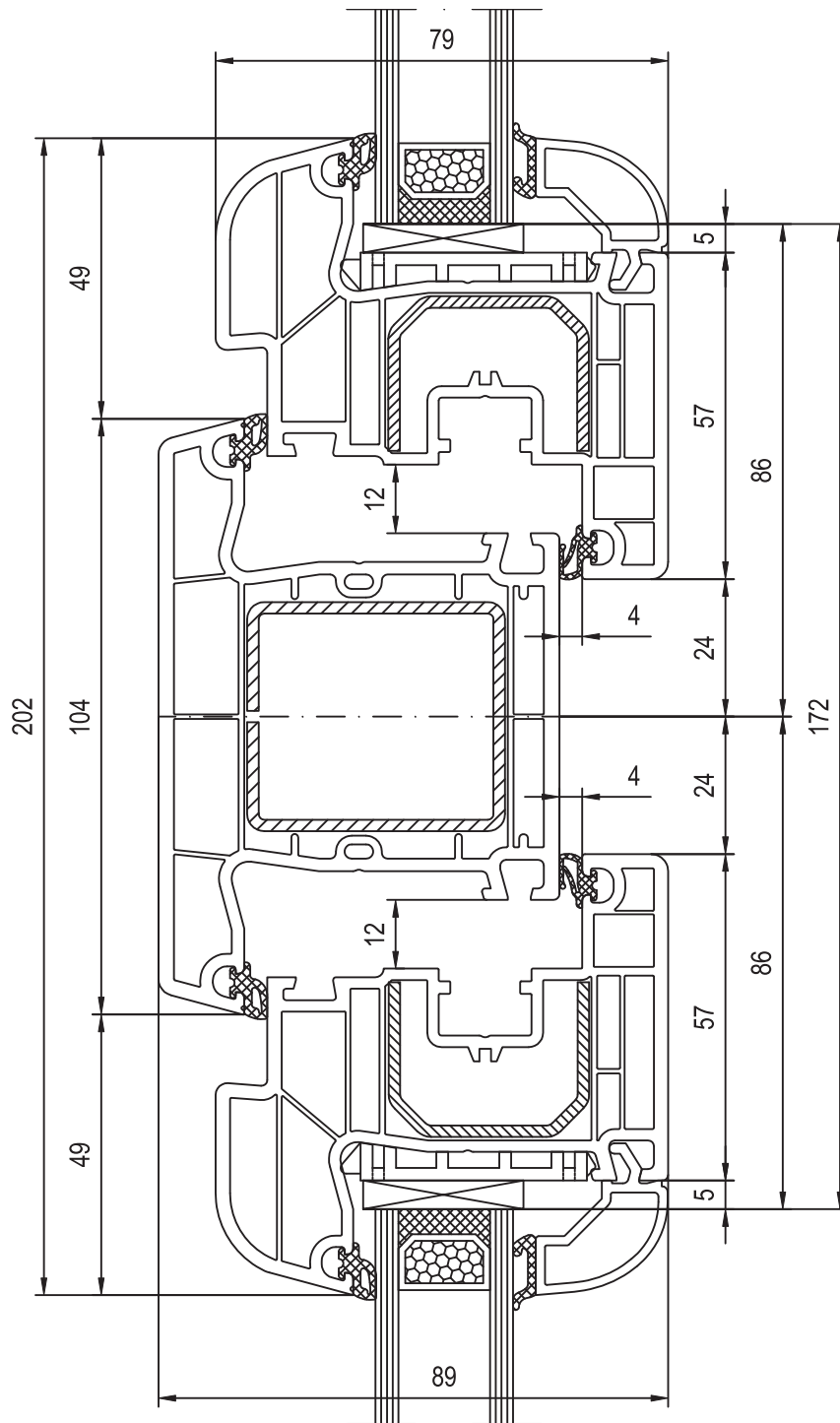

Przekrój przez słupek stały 104 mm z dwoma skrzydłami, Round-line

Coupe de deux ouvrants de fenêtre round-line avec meneau large de 104 mm

Aansluiting van twee raam vleugels round-line met brede stijl 104 mm

Zwei Fensterflügel Round-line verbunden mit Hilfe eines breiten Pfostens mit 104 mm Breite

Giunzione di due ante finestra round-line con montante 104 mm



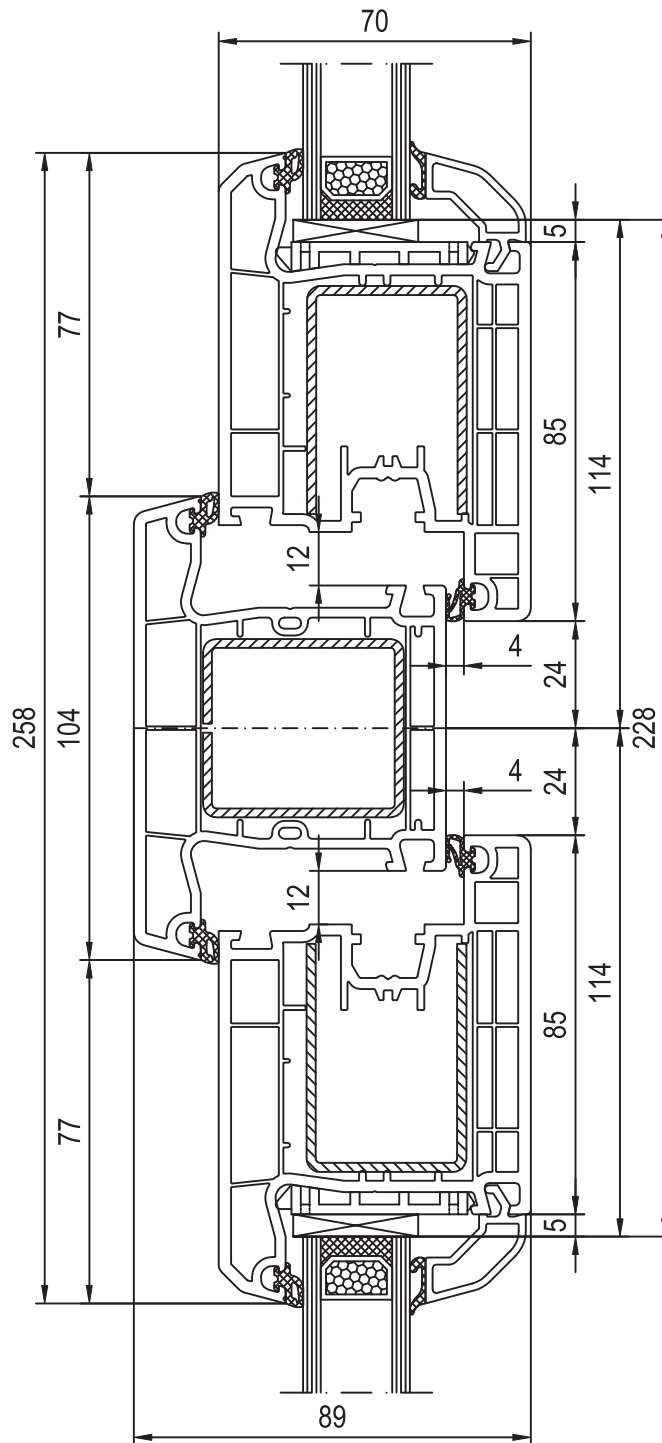

Przekrój przez słupek stały 104 mm z dwoma skrzydłami tarasowymi, otwierane do wewnątrz



Coupe de deux ouvrants de porte de passage avec meneau large de 104 mm, ouverture vers l'intérieur



Aansluiting van twee terras vleugels met brede stijl 104 mm, naar binnen opendraaiend



Zwei Terrassenflügel verbunden mit Hilfe eines breiten Pfosten mit 104 mm Breite



Giunzione di due ante portaverande con montante 104 mm, l'apertura verso interno



IDEAL 4000

140x31 - 140x45 - 140x31

**ЕКО
ОКНА**

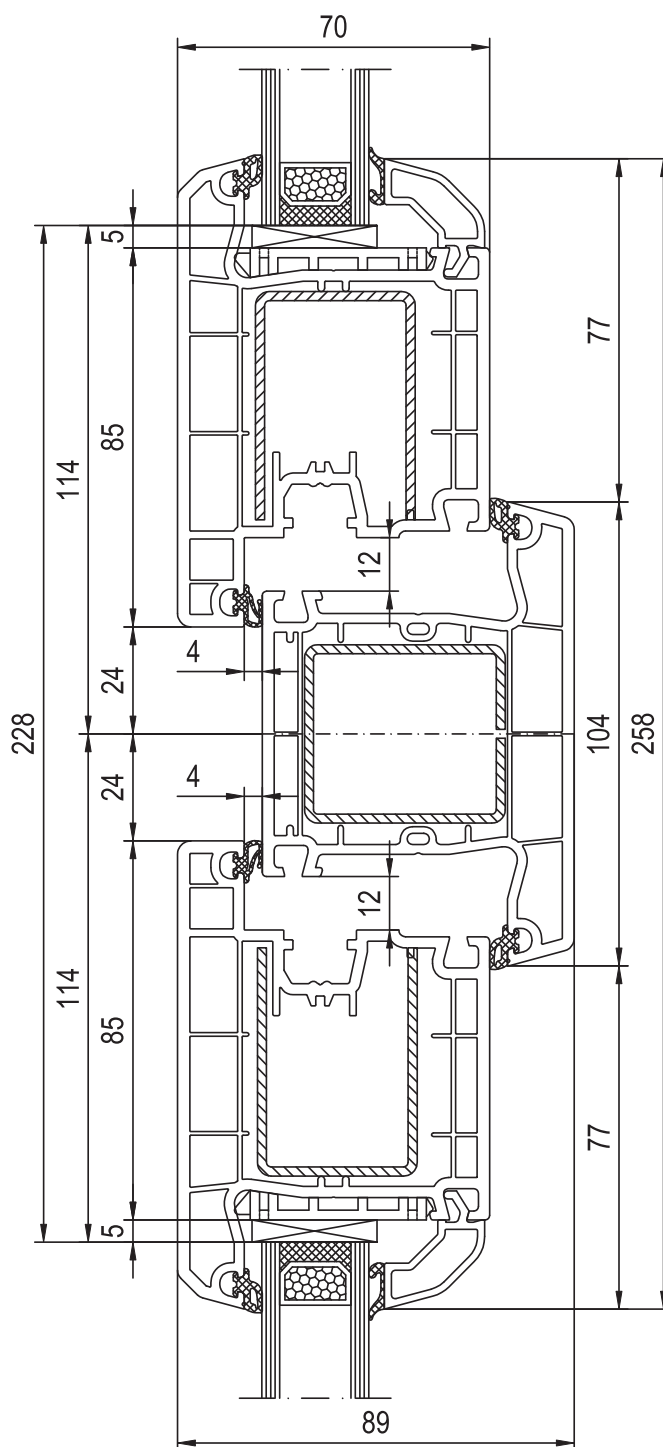

Przekrój przez słupek stały 104 mm z dwoma skrzydłami tarasowymi, otwierane na zewnątrz

Coupe de deux ouvrants de porte de passage avec meneau large de 104 mm, ouverture vers l'extérieur

Aansluiting van twee terras vleugels met brede stijl 104 mm, naar buiten opendraaiend

Zwei Terrassenflügel verbunden mit Hilfe eines breiten Pfosten mit 104 mm Breite, nach Aussen öffnend

Giunzione di due ante portaverande con montante 104 mm, l'apertura verso esterno



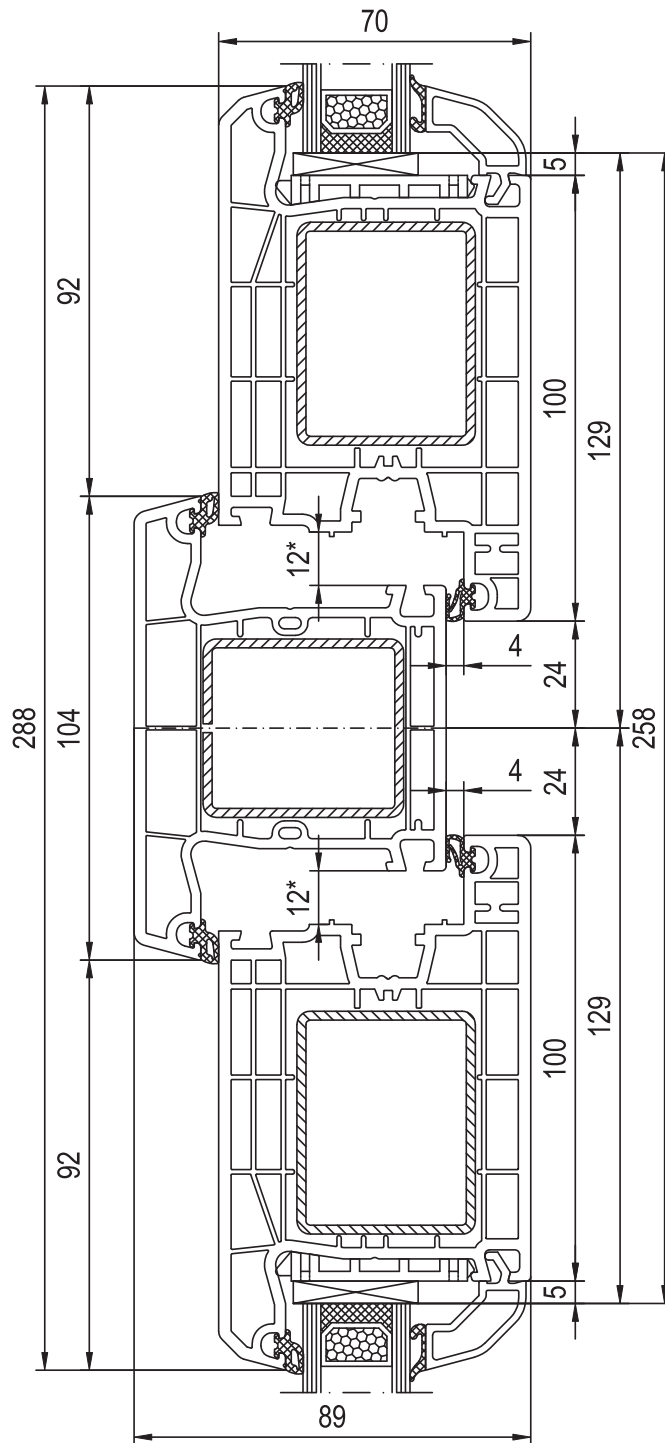

Dwa skrzydła drzwiowe ze słupkiem stałym 104 mm, otwierane do wewnątrz



Coupe de deux ouvrants de porte, meneau large de 104 mm, ouverture vers l'intérieur



Aansluiting van twee deur vleugels met brede stijl 104 mm, naar binnen opendraaiend



Zwei Türflügel mit festem Pfahl 104 mm, nach Innen öffnend



Giunzione di due ante della porta con montante 104 mm, l'apertura verso interno



IDEAL 4000

140x35 - 140x45 - 140x35

**OKO
OKNA**

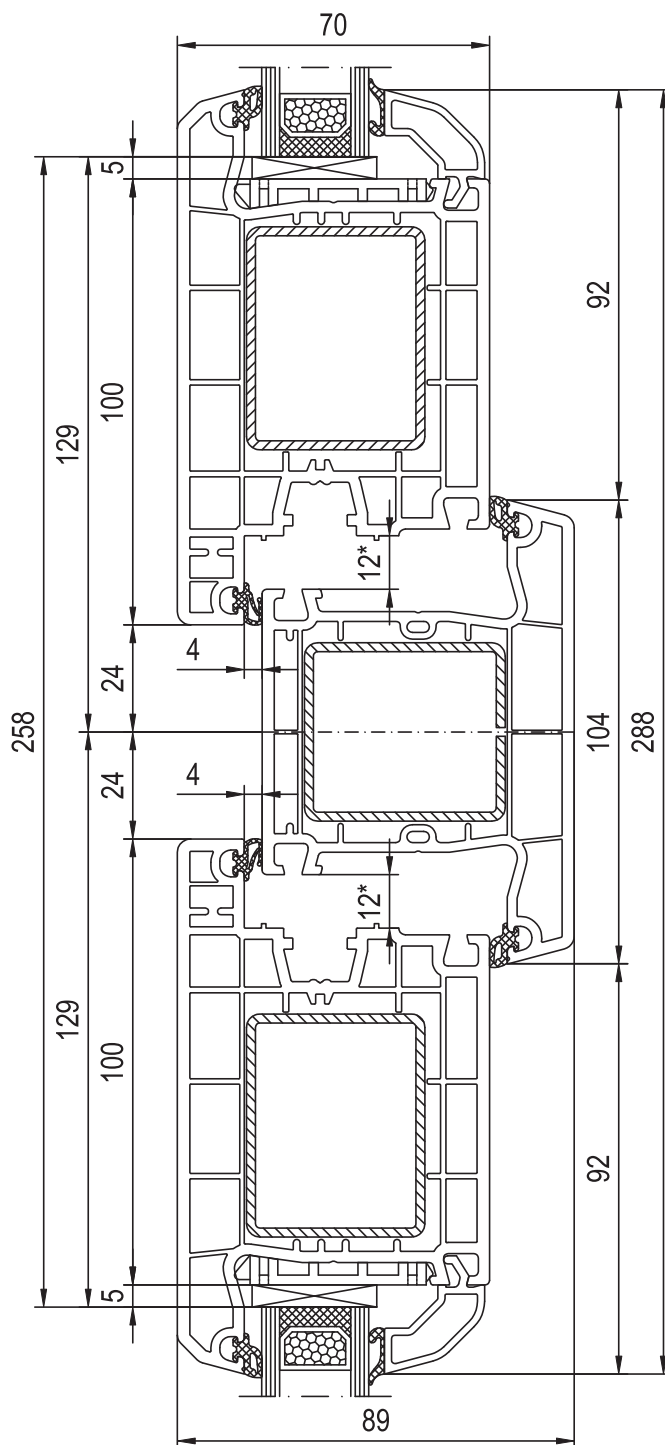

Dwa skrzydła drzwiowe ze słupkiem stałym 104 mm, otwierane na zewnątrz

Coupe de deux ouvrants de porte avec meneau large de 104 mm, ouverture vers l'extérieur

Aansluiting van twee deur vleugels met brede stijl 104 mm, naar buiten opendraaiend

Zwei Türflügel verbunden mit Hilfe eines breiten Pfosten mit 104 mm Breite, nach Aussen öffnend

Giunzione di due ante porta con montante 104 mm, l'apertura verso esterno



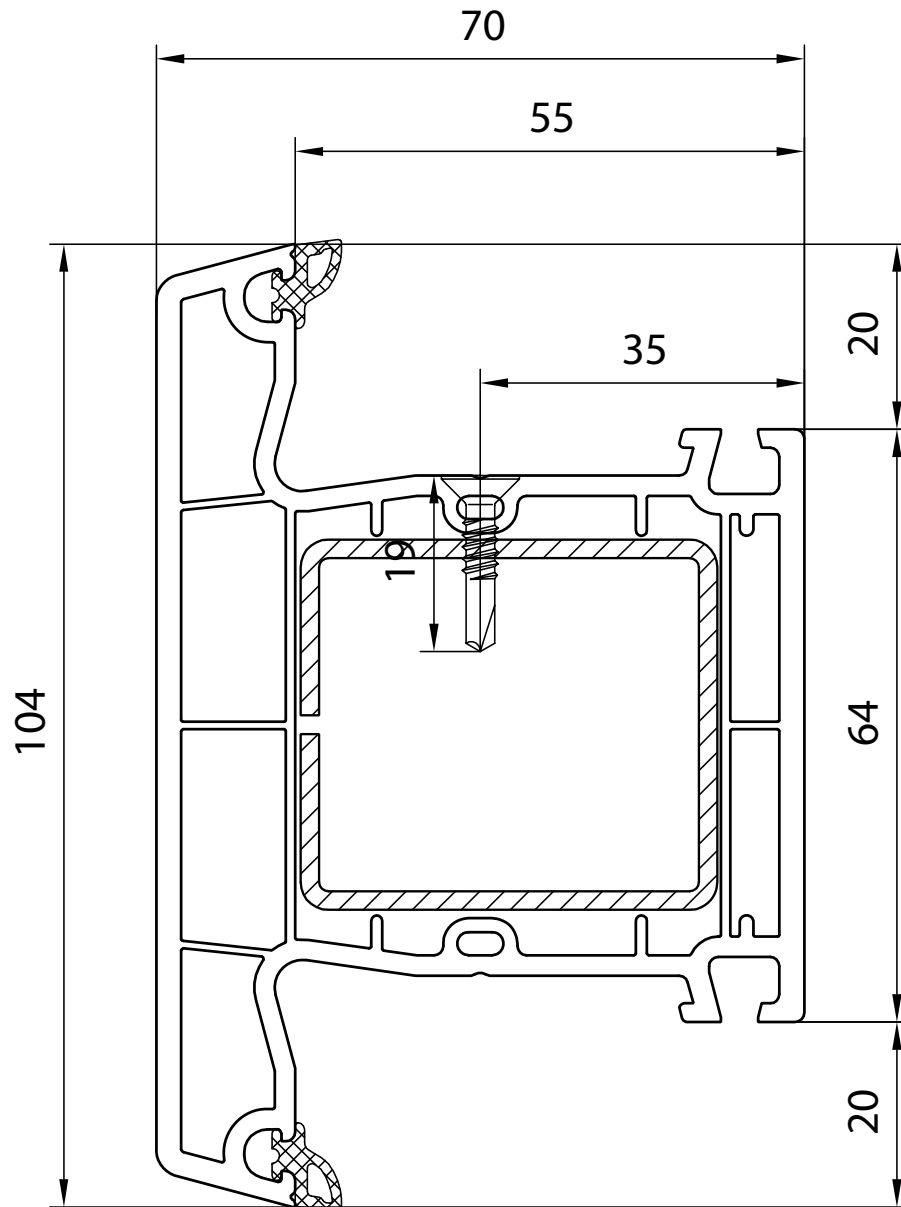

-  Słupki stały 104 mm
-  Meneau large de 104 mm
-  Brede stijl 104 mm
-  Breiter Pfosten 104 mm
-  Montante 104 mm

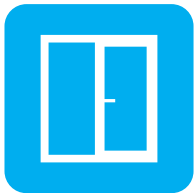

IDEAL 4000

140x20 - 140x65 - 140x20

**eko
okna**

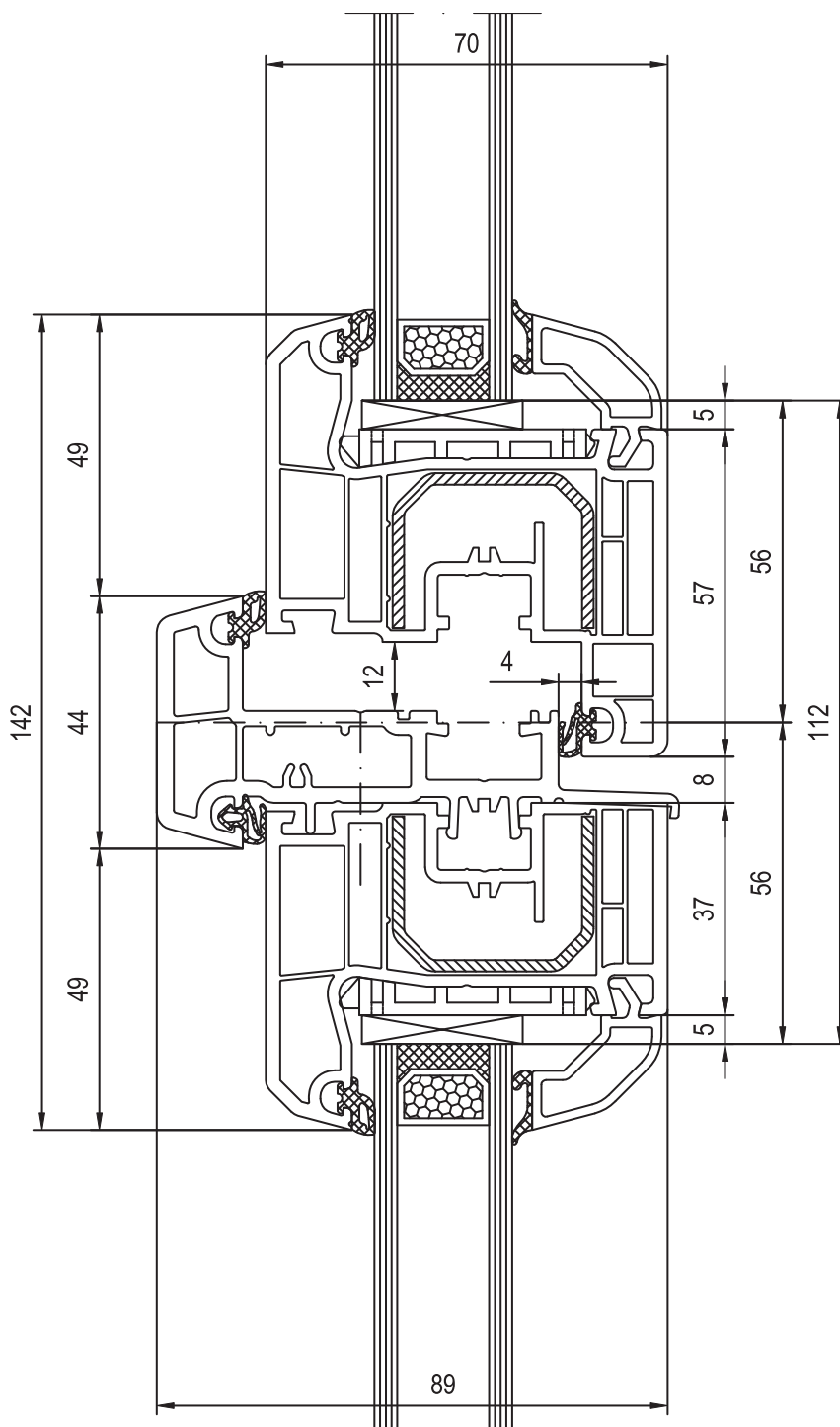

Przekrój przez połączenie dwóch skrzydeł Soft-line z wąskim słupkiem

Coupe de deux ouvrants de fenêtre Soft-line avec meneau étroit mobile





Aansluiting van twee raam vleugels Soft-line met smalle mobile paal

Zwei Fensterflügel verbunden mit Hilfe eines Schmalen Stulps

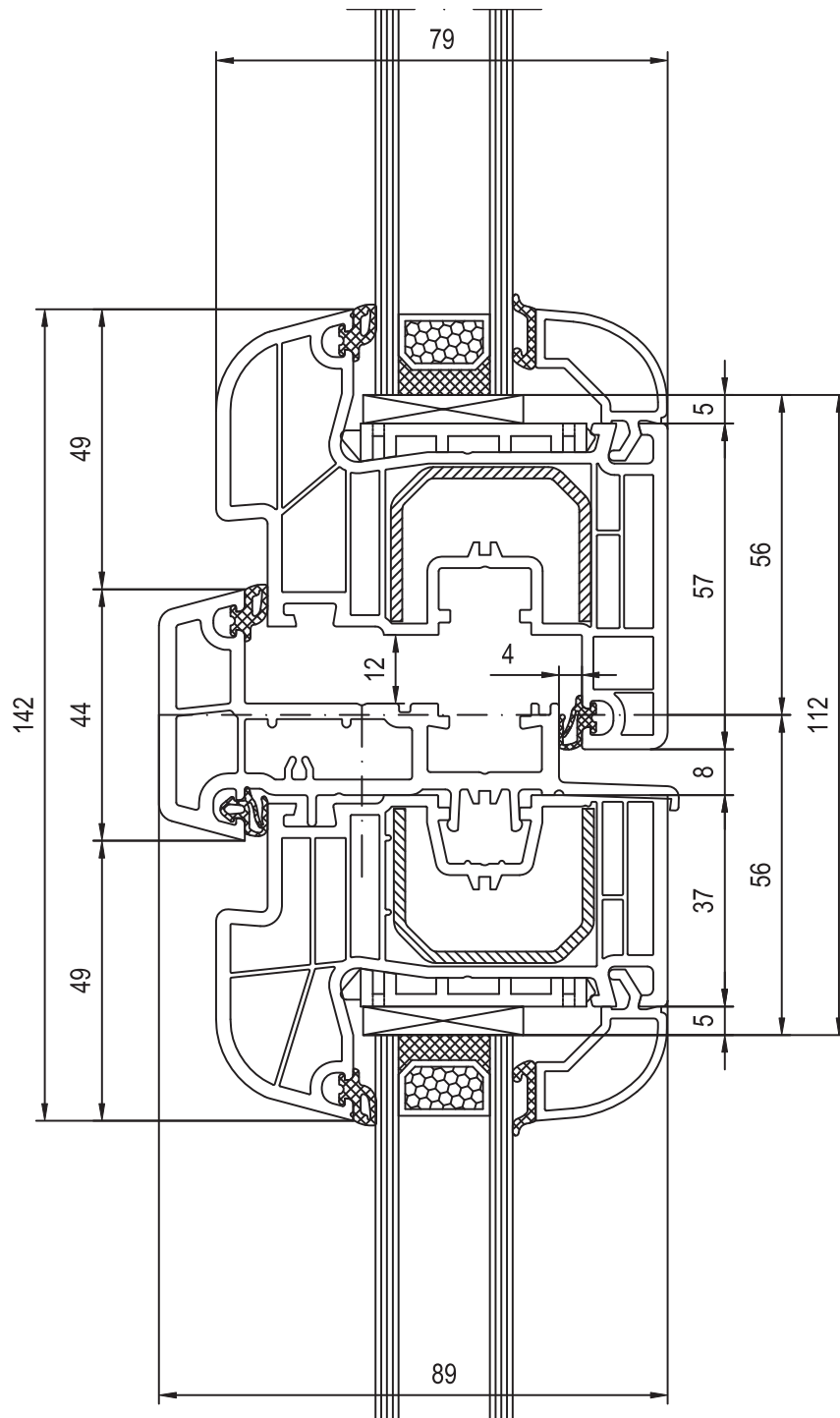
Giunzione di due ante finestra Soft-line con montante stretto





-  Przekrój przez połączenie dwóch skrzydeł Round-line z wąskim słupkiem
-  Coupe de deux ouvrants de fenêtre Round-line avec meneau étroit mobile
-  Aansluiting van twee raam vleugels Round-line met smalle mobile paal
-  Zwei Fensterflügel Round-line verbunden mit Hilfe eines Schamlen Stulpes
-  Giunzione di due ante finestra Round-line con montante stretto



IDEAL 4000

140x65

**OKO
OKNA**

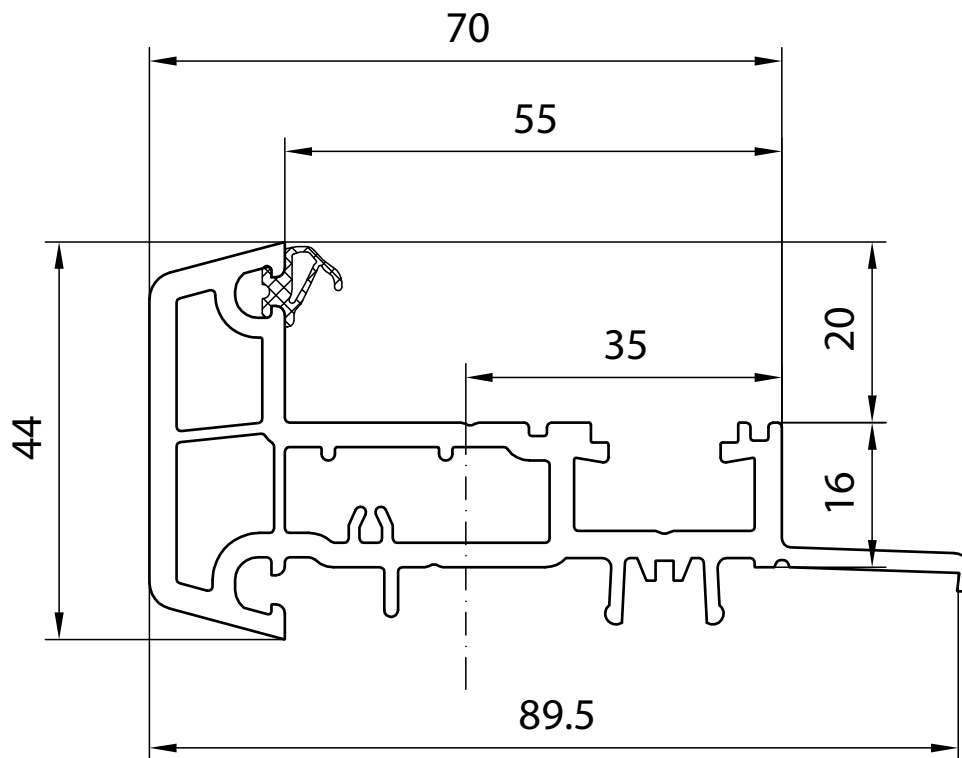

Słupek ruchomy, wąski 44 mm 

Meneau mobile étroit de 44 mm 

Smalle stijl 44 mm stulp 

Schmaler Stulp 44 mm 

Montante stretto mobile 44 mm 

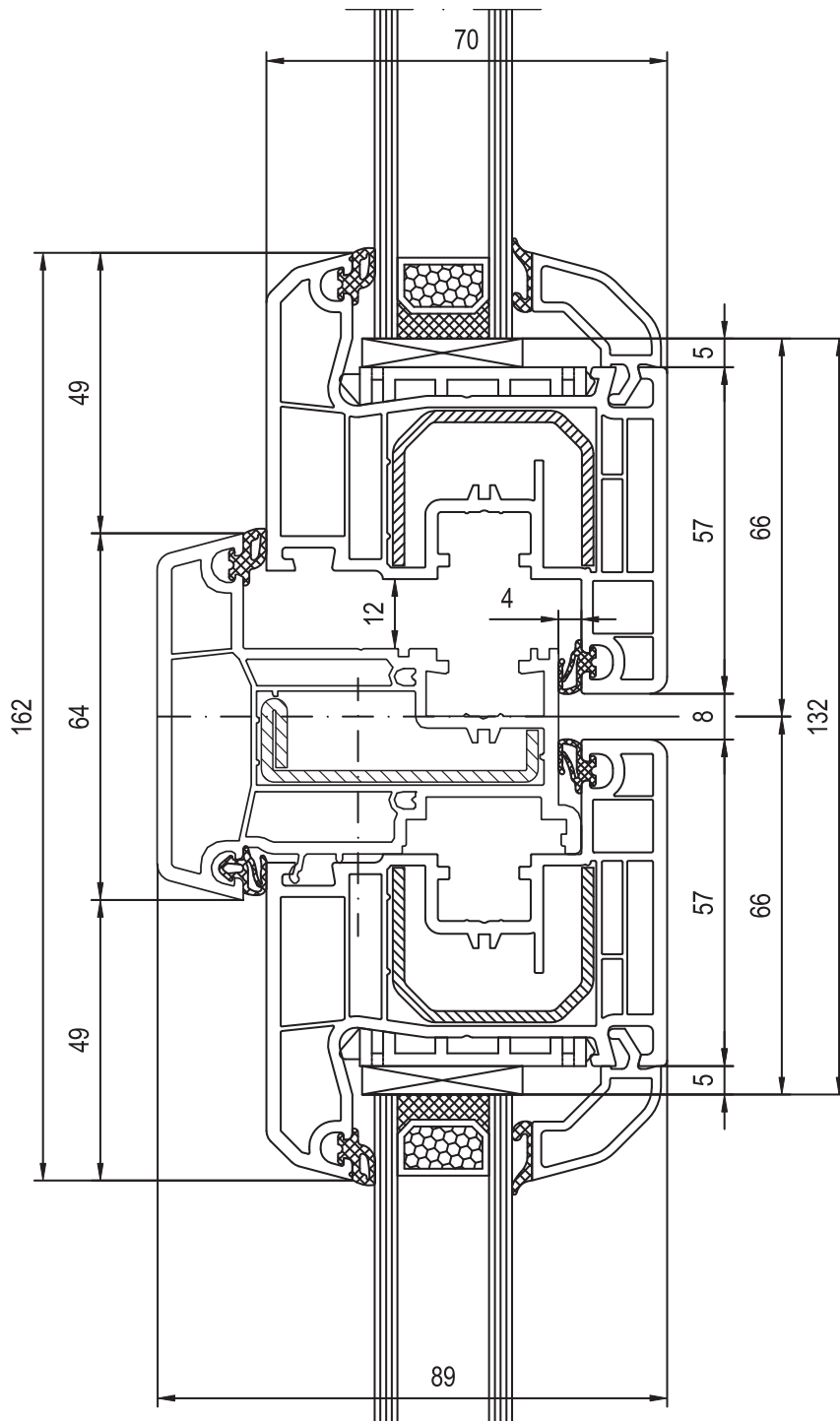

Przekrój przez ruchomy słupek 64 mm z dwoma skrzydłami Soft-line



Coupe de deux ouvrants Soft-line avec meneau mobile de 64 mm



Aansluiting van twee raam vleugels Soft-line met brede stijl 64 mm



Zwei Flügel Soft-line verbunden mit Hilfe eines breiten Stulps mit 64 mm Breite



Giunzione di due ante Soft-line, montante mobile 64 mm

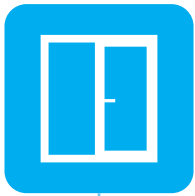

IDEAL 4000

140x22 - 140x66 - 140x22

**OKO
OKNA**

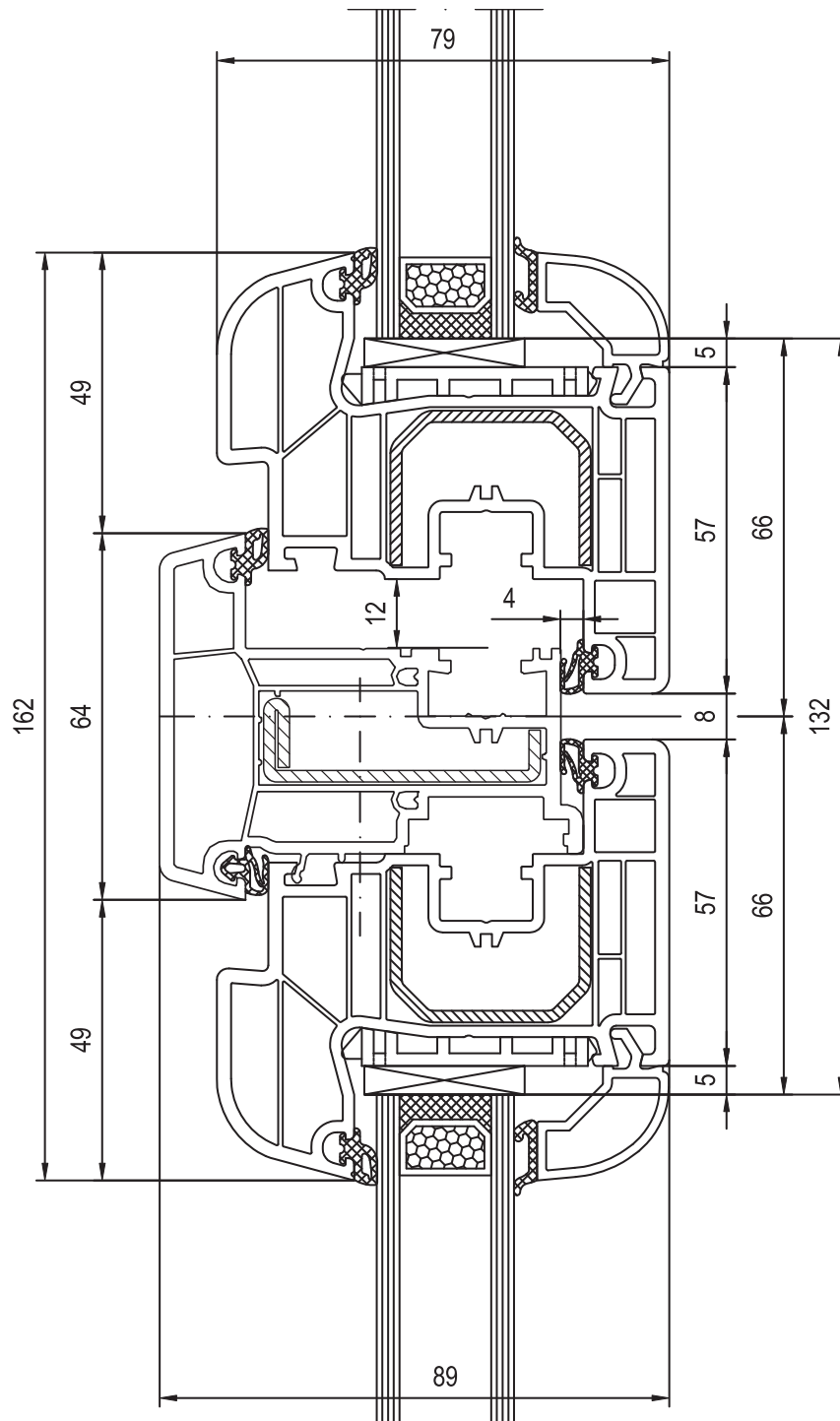

Przekrój przez ruchomy słupek 64 mm z dwoma skrzydłami Round-line

Coupe de deux ouvrants Round-line avec meneau mobile de 64 mm





Aansluiting van twee raam vleugels Round-line met brede stijl 64 mm

Zwei Flügel Round-line verbunden mit Hilfe eines breiten Stulpes mit 64 mm Breite

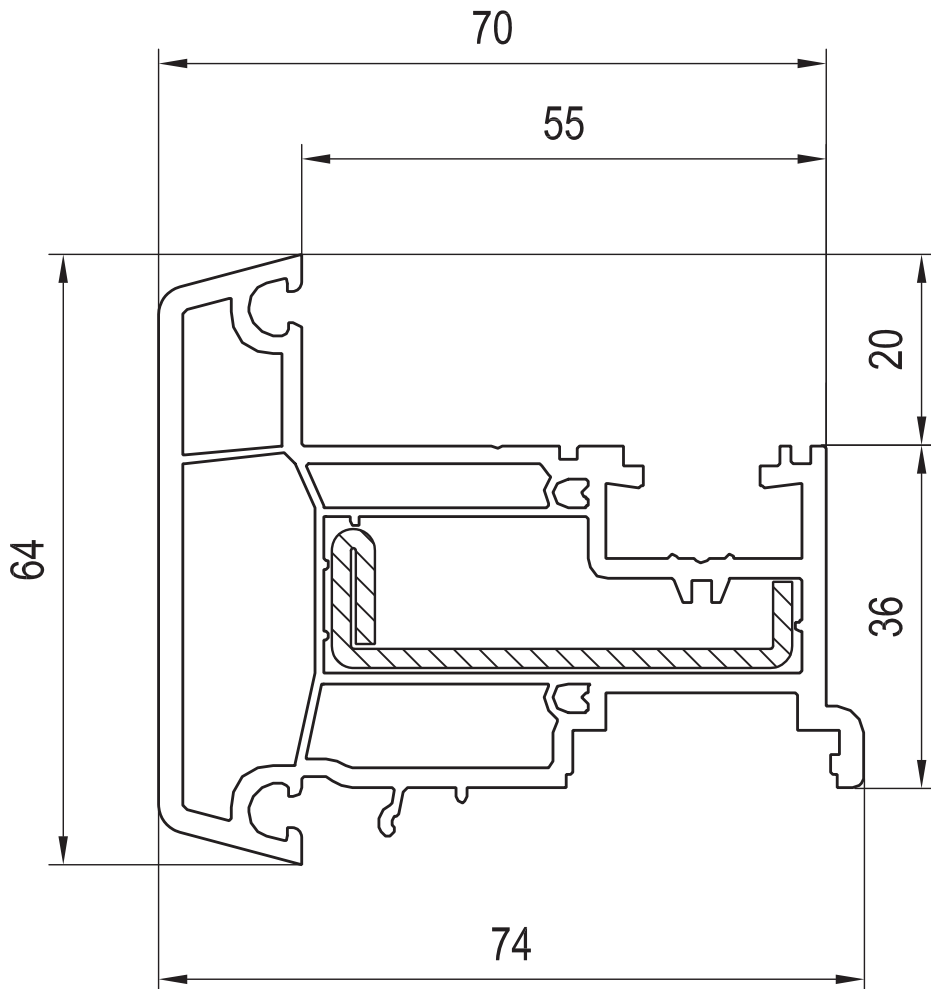
Giunzione di due ante Round-line con montante mobile 64 mm





-  Ruchomy slupek 64 mm
-  Meneau mobile de 64 mm
-  Brede stijl 64 mm stulp
-  Breiter Stulp 64 mm
-  Montante mobile 64 mm



IDEAL 4000

140x76 - 140x20

**OKO
OKNA**

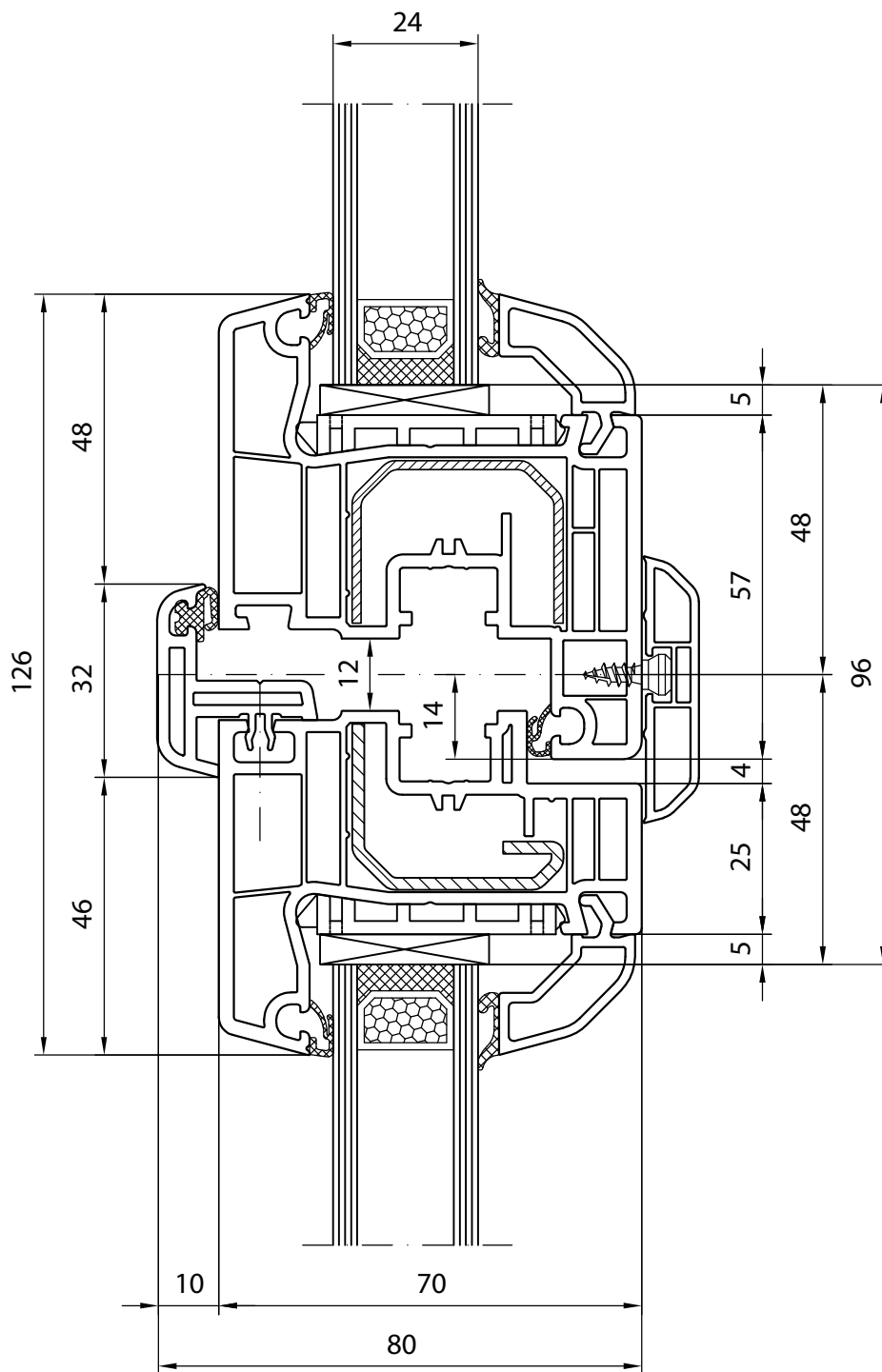

Klamka centralna, skrzydło Classic-line

Battue centrée, ouvrant Classic-line





Centrale kruk, vleugel Classic-line

Zentrale Olive, Flügel Classic-line

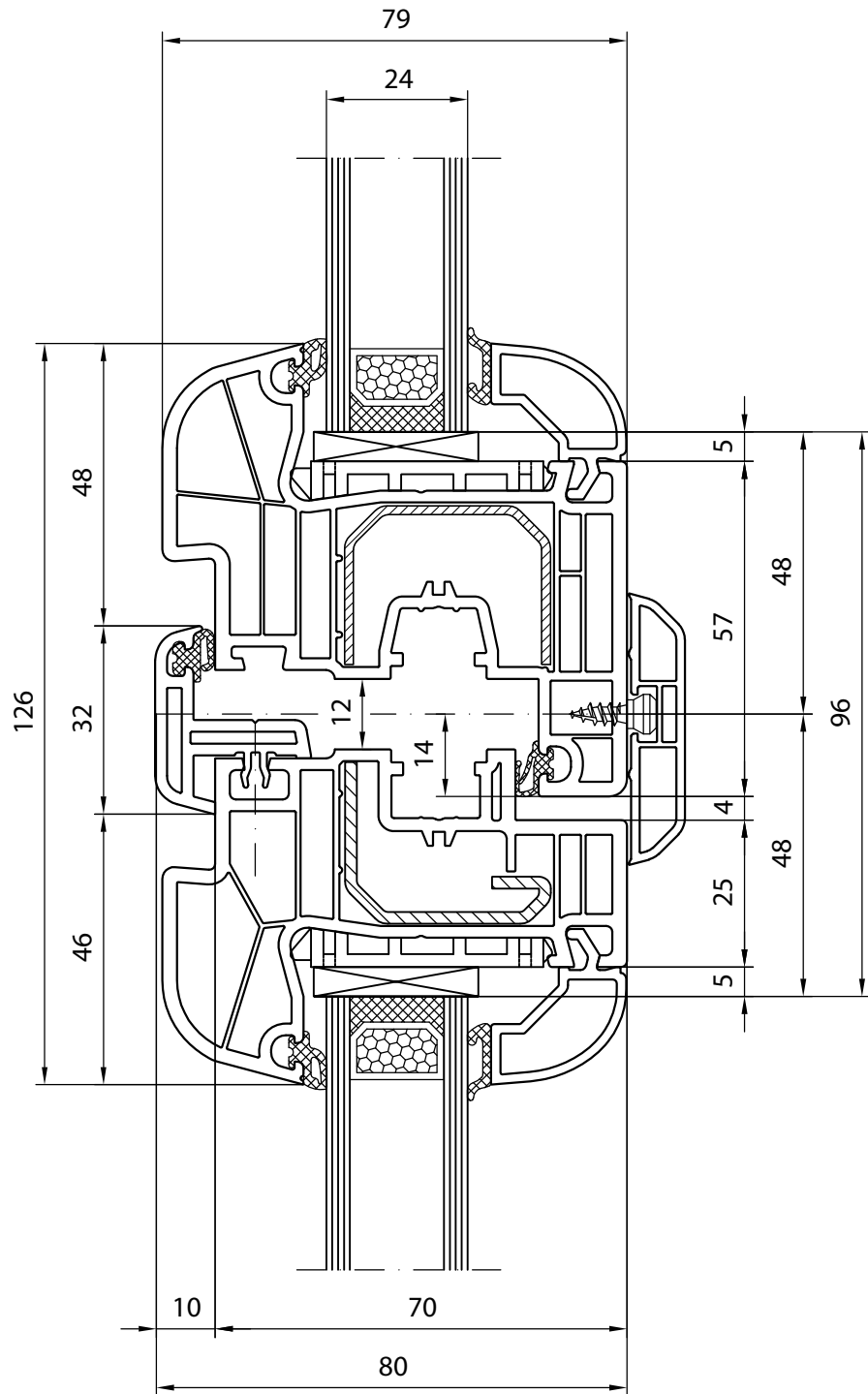
Maniglia centrale, ante Classic-line





-  Klamka centralna, skrzydło Round-line
-  Battue centrée, ouvrant Round-line
-  Centrale kruk, vleugel Round-line
-  Zentrale Olive, Flügel Round-line
-  Maniglia centrale, ante Round-line

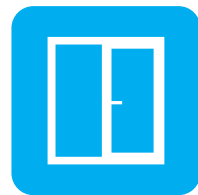

IDEAL 4000 NEW Round-line

IDEAL 4000 NEW Soft-line



IDEAL 4000 NEW | 5 komór | 2 uszczelki
Stal pokazana na rysunku może nie być stalą stosowaną standardowo.



IDEAL 4000 NEW | 5 chambres | 2 joints
Renfort en acier présenté sur le dessin ci-dessus est en option.



IDEAL 4000 NEW | 5 kamer | 2 afdichtingen
Staal die u op de tekening ziet, is niet standaard.



IDEAL 4000 NEW | 5 Kammern | 2 Dichtungen
Der angewendete Stahlkern kann von dem abgebildeten Kern abweichen.



IDEAL 4000 NEW | 5 camere | 2 guarnizioni
L'acciaio presentato sul disegno può essere un acciaio non standard.



IDEAL 4000 NEW

140x00 - 140x20

**OKO
OKNA**

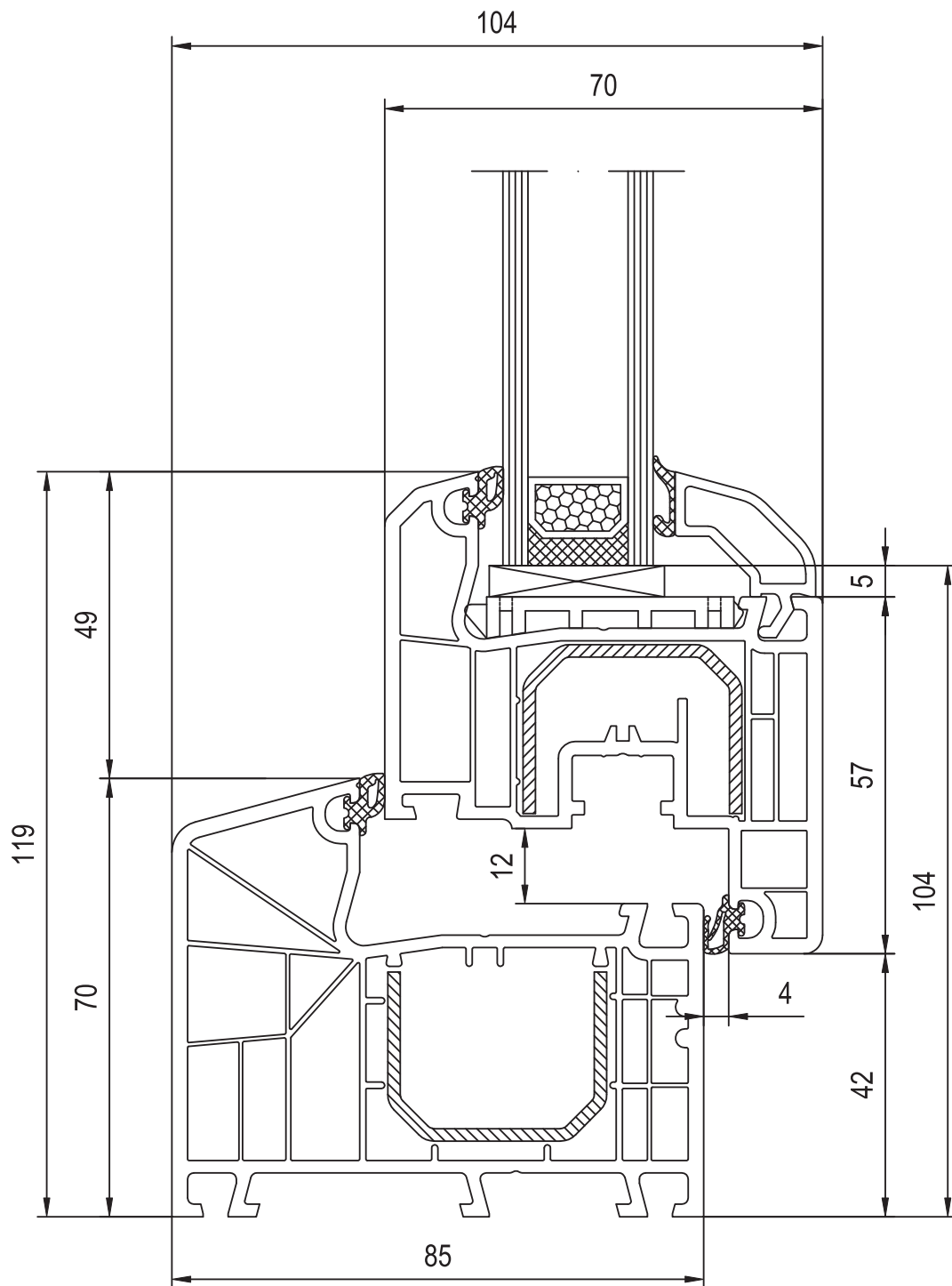

Skrzydło Soft-line 

Ouvrant Soft-line 

Vleugel Soft-line 

Flügel Soft-line 

Ante Soft-line 

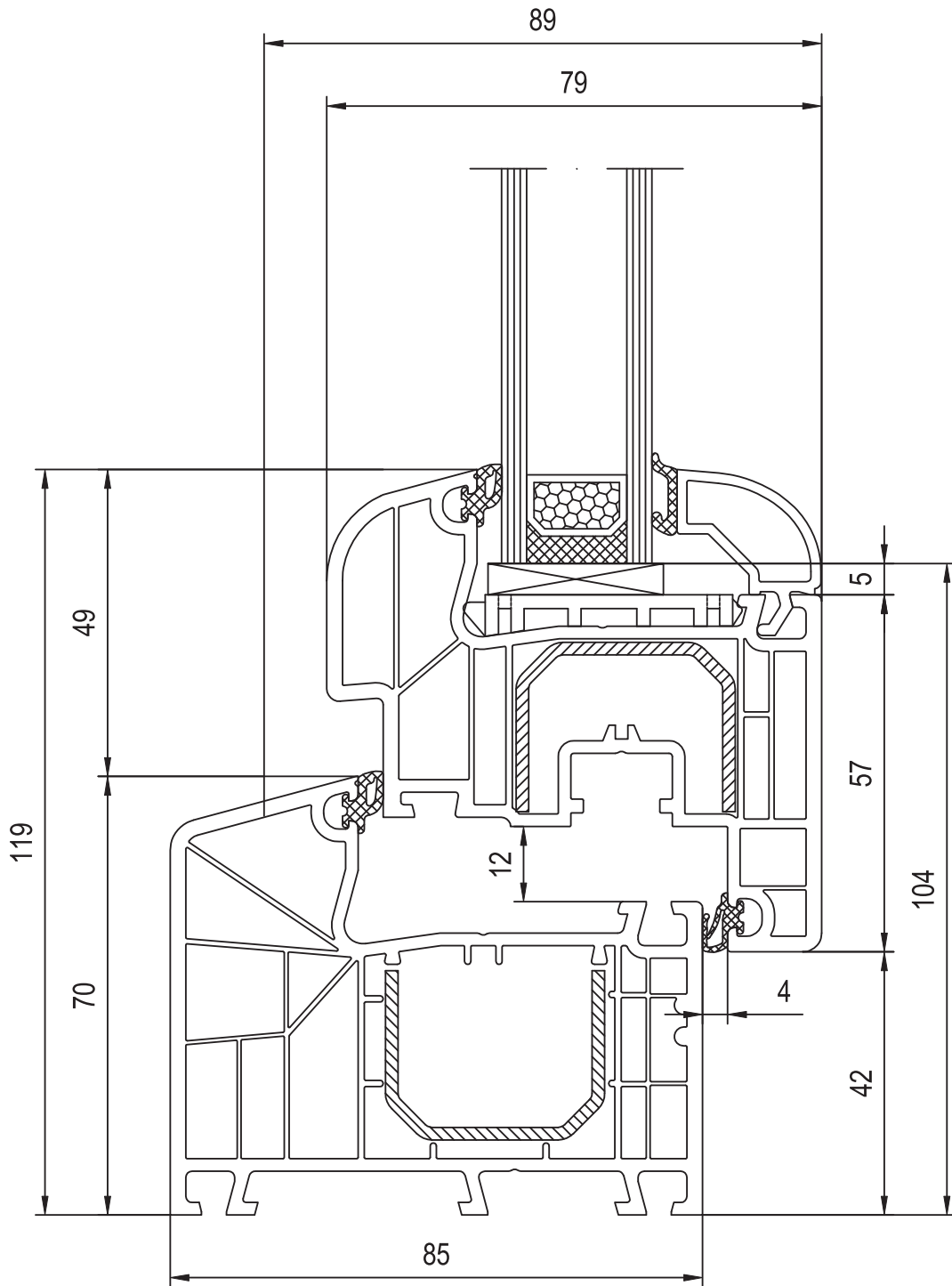

-  Skrzydło Round-line
-  Ouvrant Round-line
-  Vleugel Round-line
-  Flügel Round-line
-  Ante Round-line



IDEAL 4000 NEW

140x00 - 140x30

**OKO
OKNA**

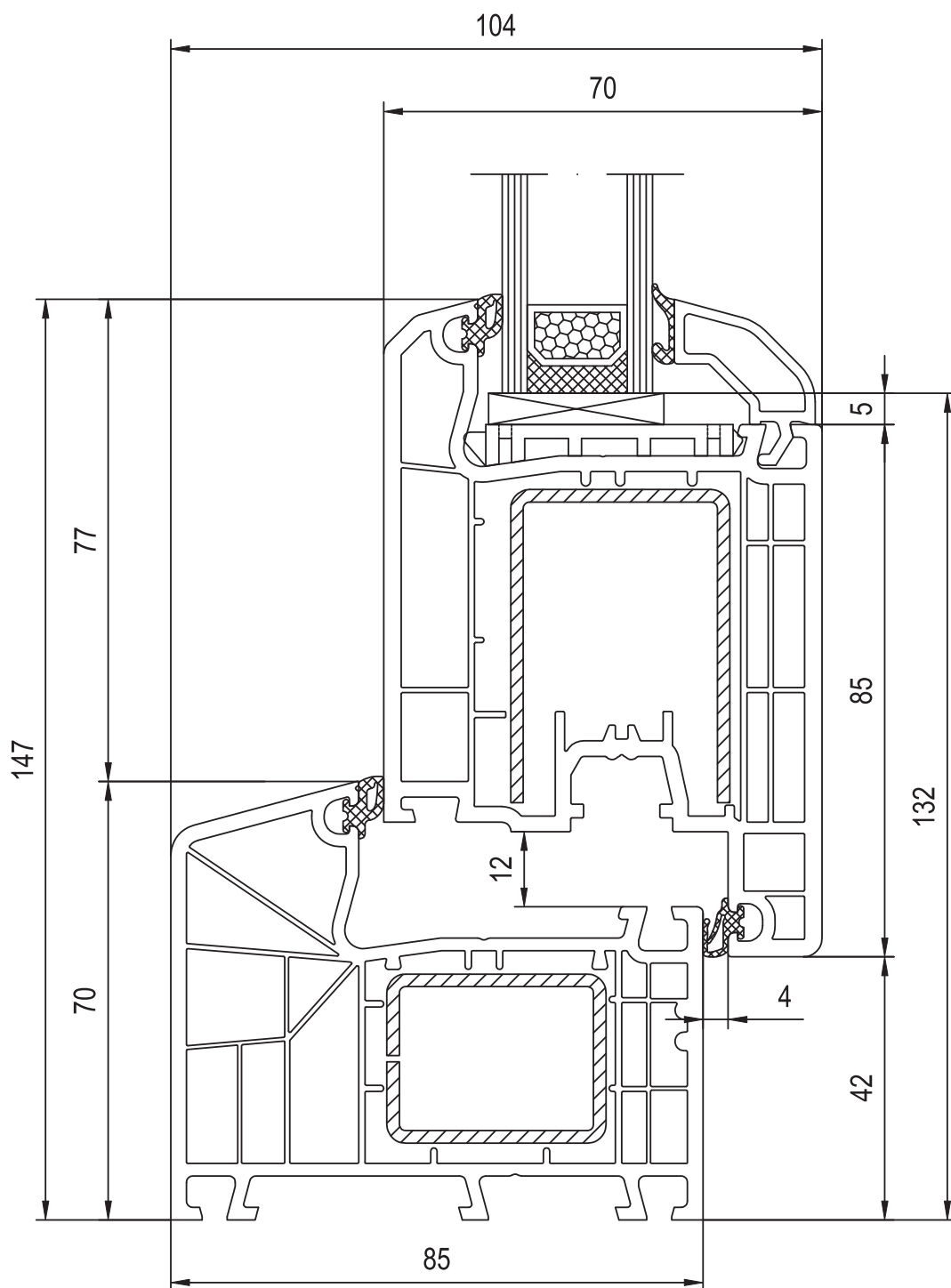

Skrzydło tarasowe, otwierane do wewnątrz

Ouvrant de passage, ouverture vers l'intérieur





Terras profiel, naar binnen opendraaiend

Terassenflügel nach Innen öffnend

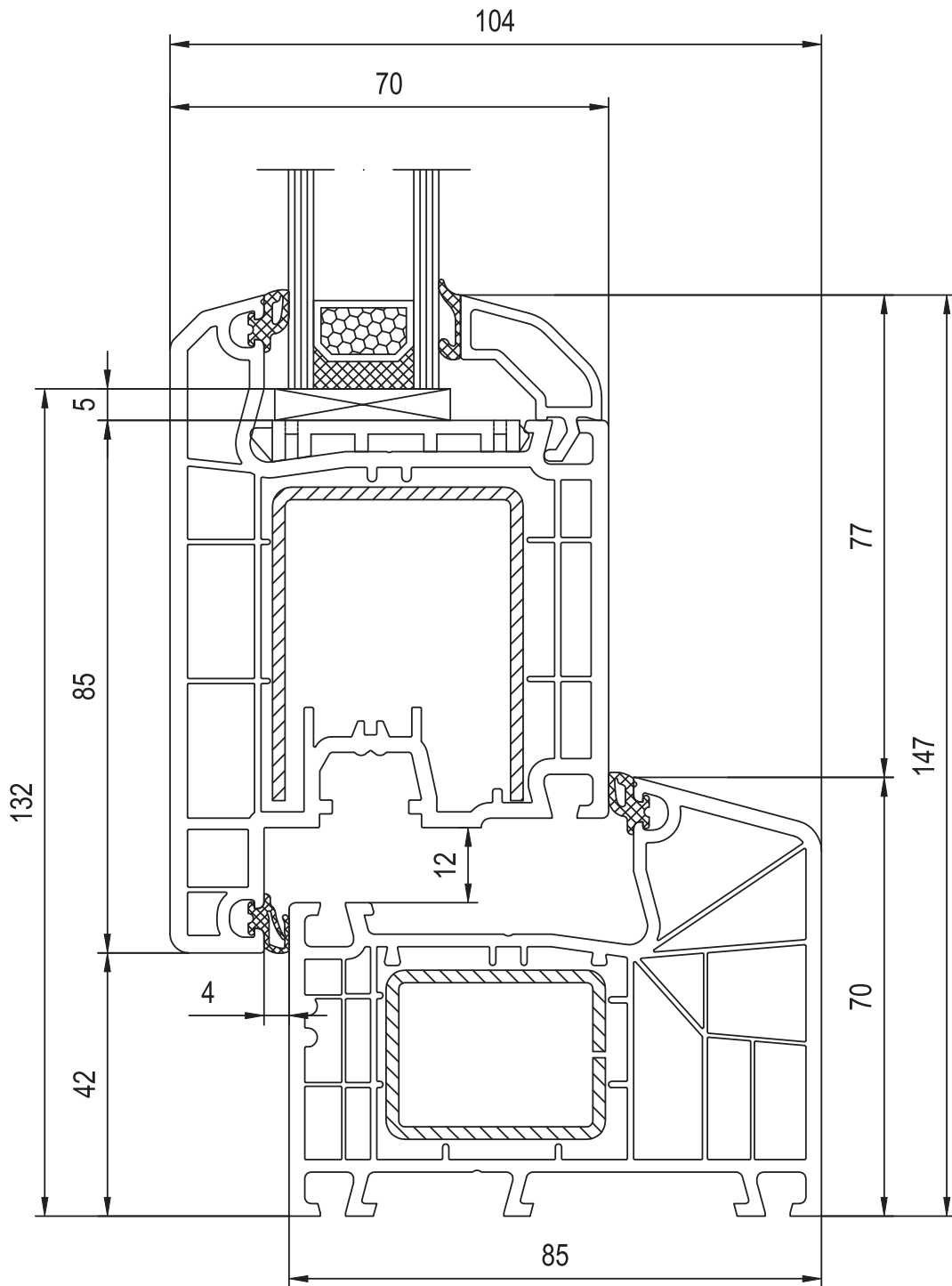
Anta della portaveranda, l'apertura verso interno





-  Skrzydło tarasowe, otwierane na zewnątrz
-  Ouvrant de passage, ouverture vers l'extérieur
-  Terras profiel, naar buiten opendraaiend
-  Terrassenflügel nach Aussen öffnend
-  Anta della portaveranda, l'apertura verso esterno



IDEAL 4000 NEW

140x00 - 140x33

**OKO
OKNA**

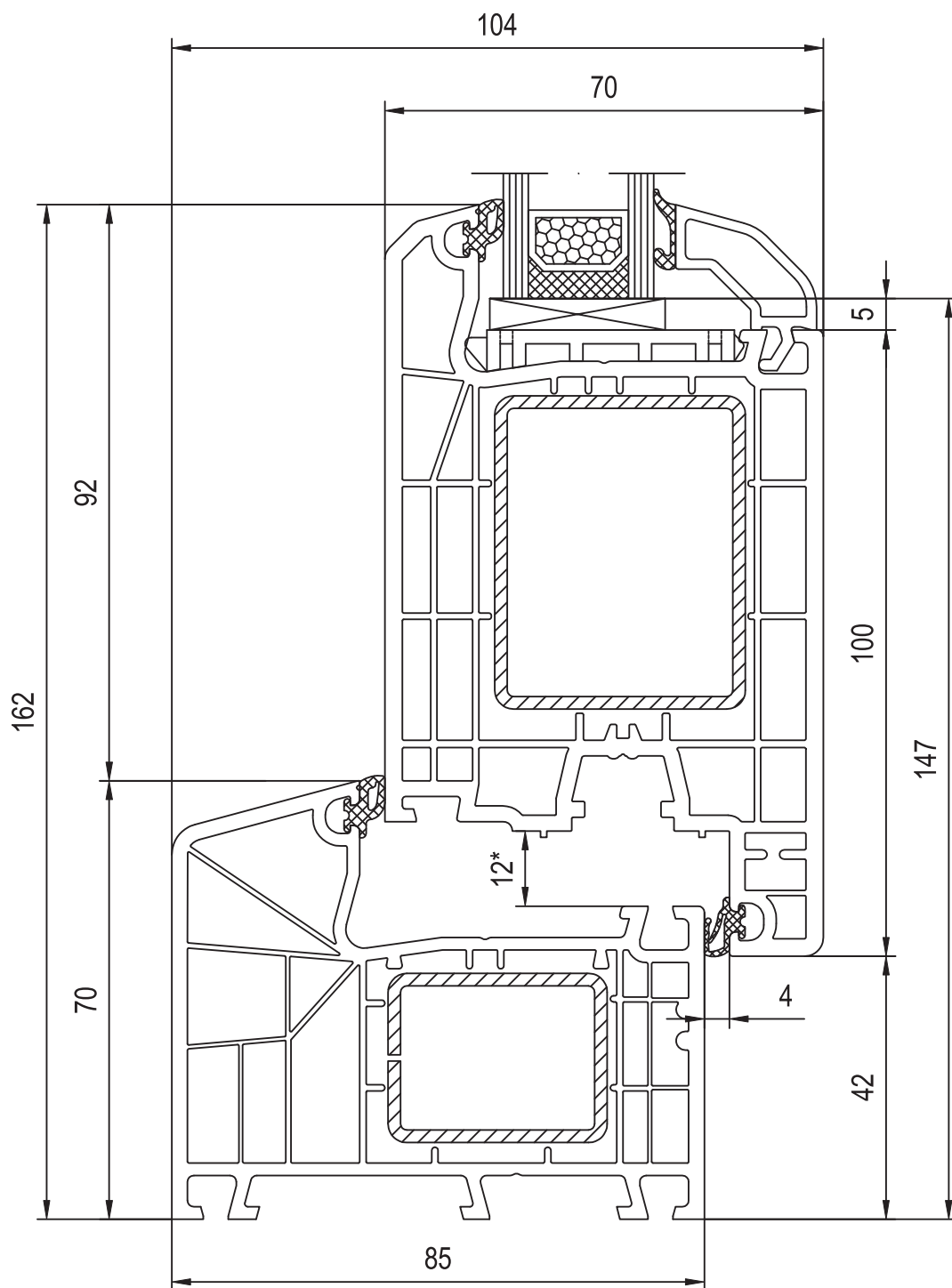

Skrzydło drzwiowe z ramą Ideal 4000 new, otwierane do wewnątrz

Ouvrant de porte, dormant Ideal 4000 new, ouverture vers l'intérieur

Deur vleugel op het kader Ideal 4000 nieuw, naar binnen opendraaiend

Türflügel mit Rahmen Ideal 4000 neu, nach Innen öffnend

Anta della porta sul telaio Ideal 4000 neu, l'apertura verso interno



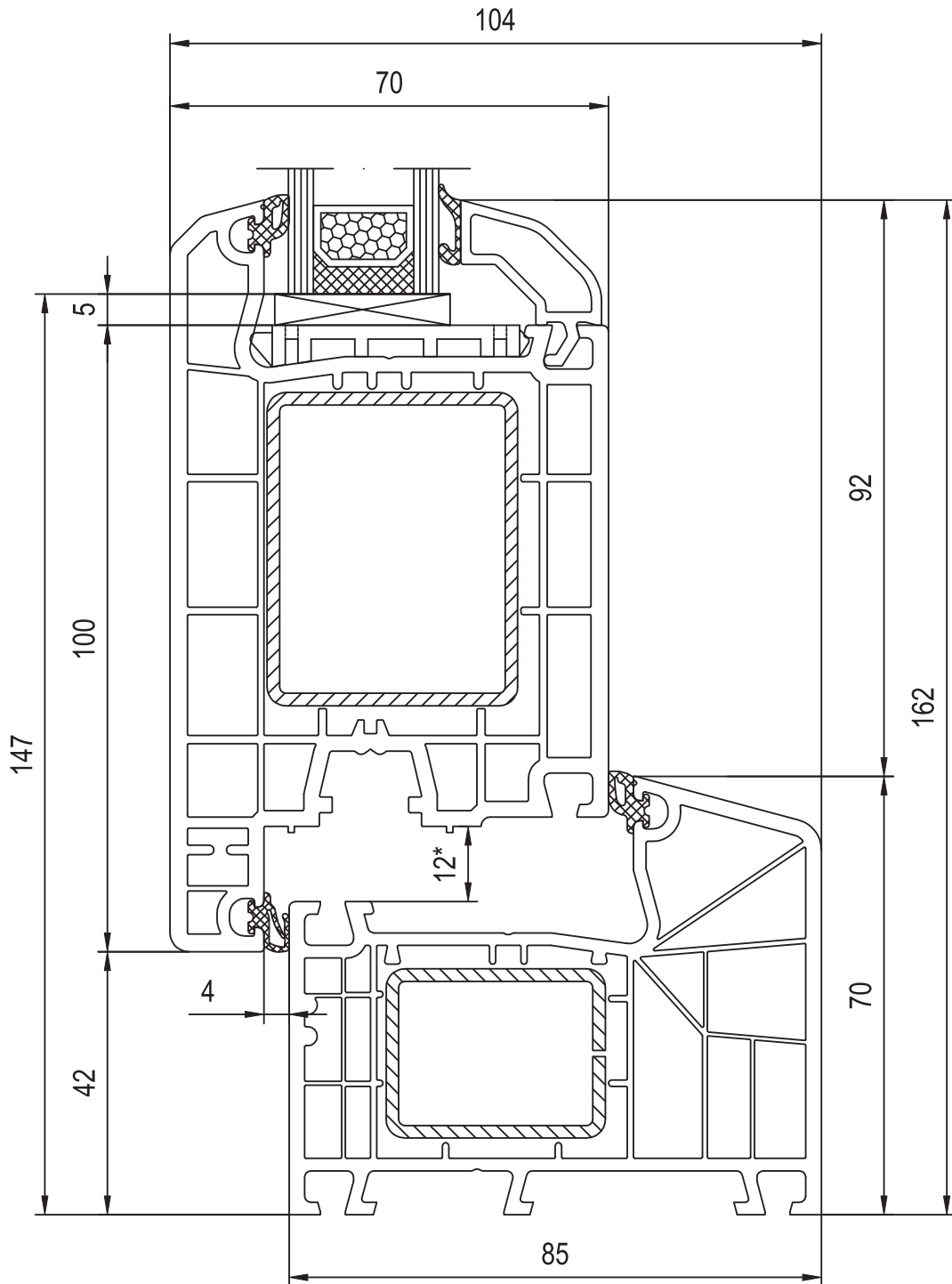

Skrzydło drzwiowe z ramą Ideal 4000 new, otwierane na zewnątrz



Ouvrant de porte, dormant Ideal 4000 new, ouverture vers l'extérieur



Deur vleugel op het kader Ideal 4000 nieuw, naar buiten opendraaiend



Türflügel mit Rahmen Ideal 4000 neu, nach Aussen öffnend



Anta della porta sul telaio Ideal 4000 neu, l'apertura verso esterno

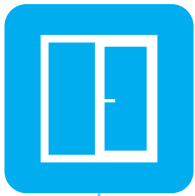

IDEAL 4000 NEW

140x00

**OKO
OKNA**

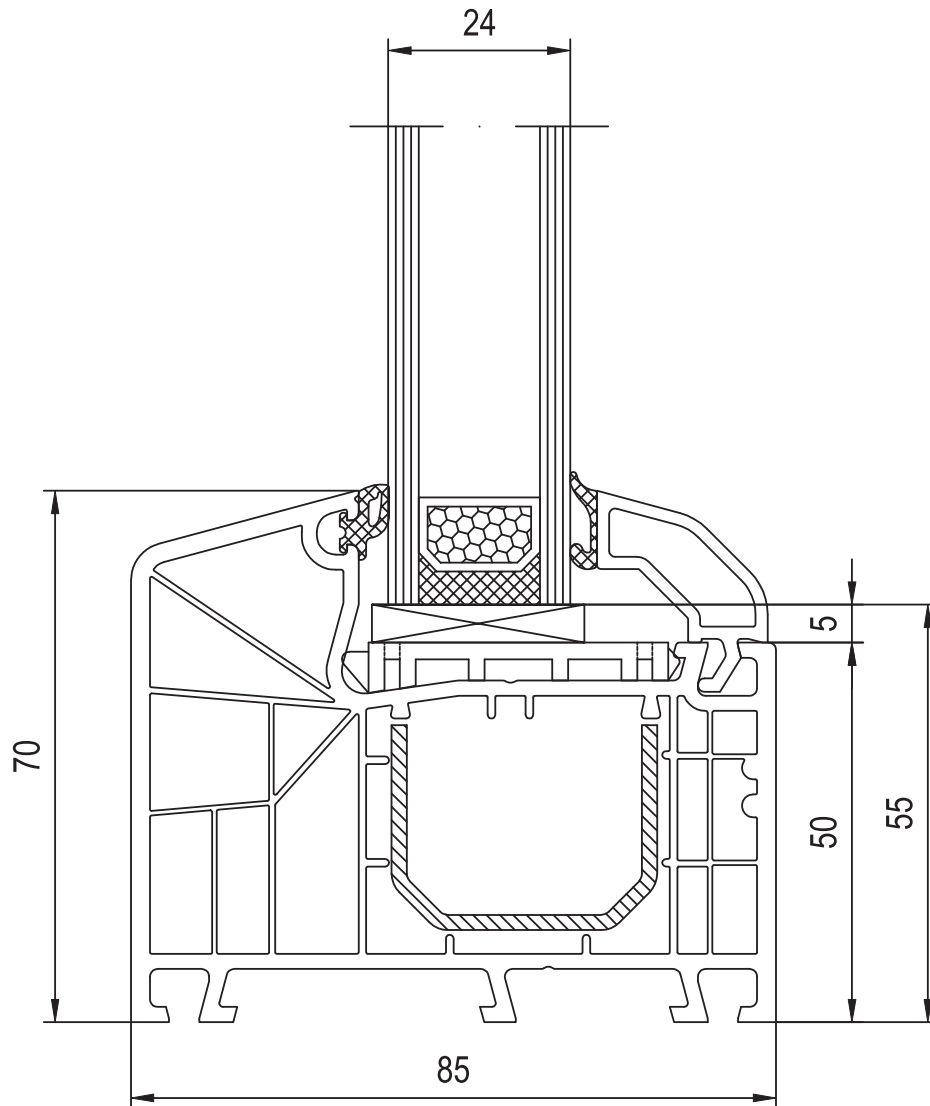

Szklenie stałe w ramie



Dormant fixe



Vast kader



Fest im Rahmen



Serramento fisso



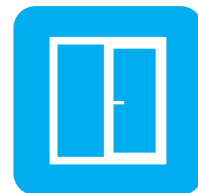

IDEAL 5000 | 5 komór | 3 uszczelki
Stal pokazana na rysunku może nie być stalą stosowaną standardowo.



IDEAL 5000 | 5 chambres | 3 joints
Renfort en acier présenté sur le dessin ci-dessus est en option.



IDEAL 5000 | 5 kamers | 3 afdichtingen
Staal die u op de tekening ziet, is niet standaard.



IDEAL 5000 | 5 Kammern | 3 Dichtungen
Der angewendete Stahlkern kann von dem abgebildeten Kern abweichen.



IDEAL 5000 | 5 camere | 3 guarnizioni
L'acciaio presentato sul disegno può essere un acciaio non standard.



IDEAL 5000

150x02 - 150x20

**OKO
OKNA**

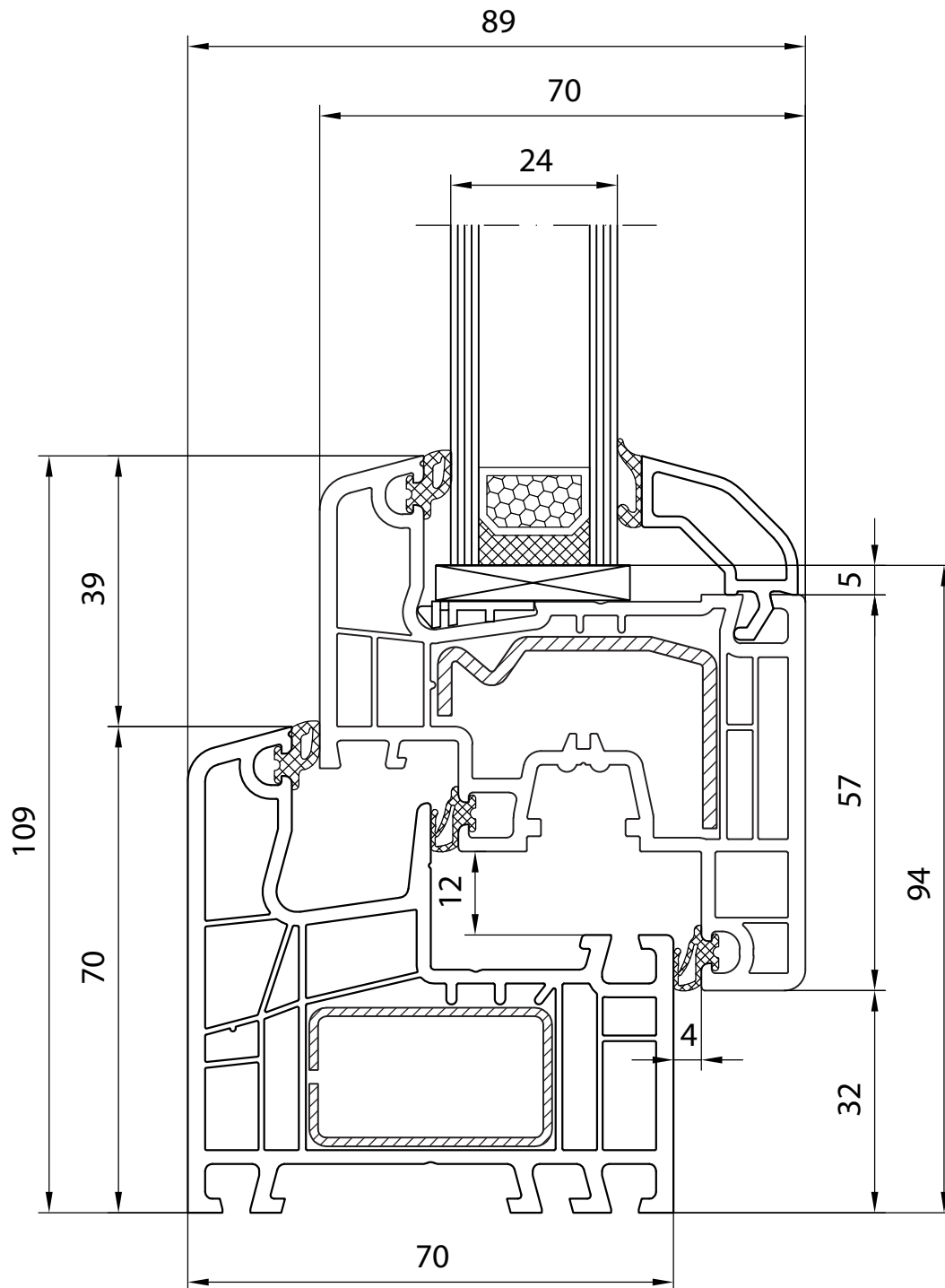

Skrzydło Classic-line



Ouvrant Classic-line



Vleugel Classic-line



Flügel Classic-line



Ante Classic-line



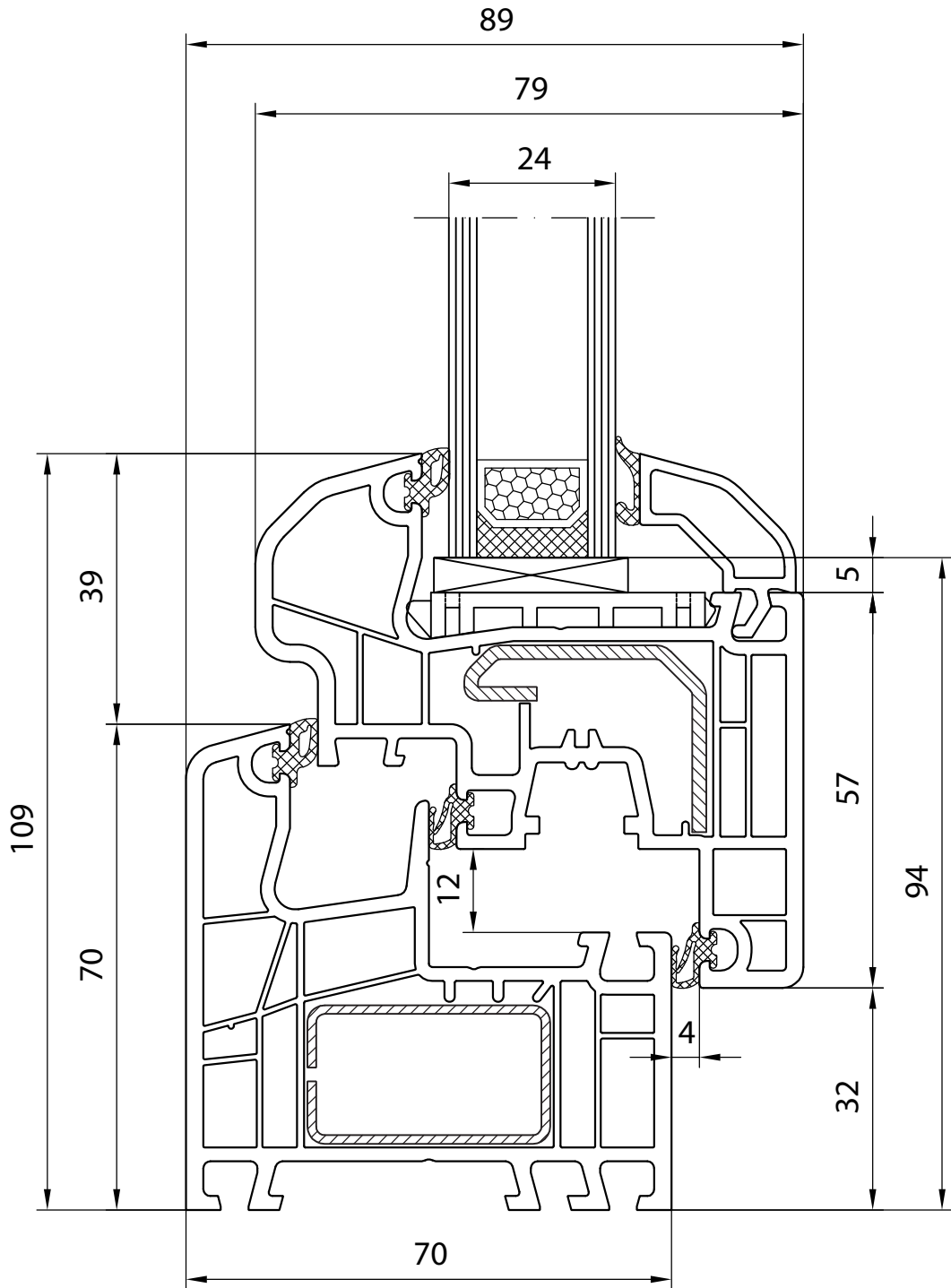
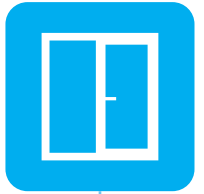

-  Skrzydło Round-line
-  Ouvrant Round-line
-  Vleugel Round-line
-  Flügel Round-line
-  Ante Round-line

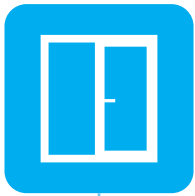

IDEAL 5000

150x03 - 150x20

**OKO
OKNA**

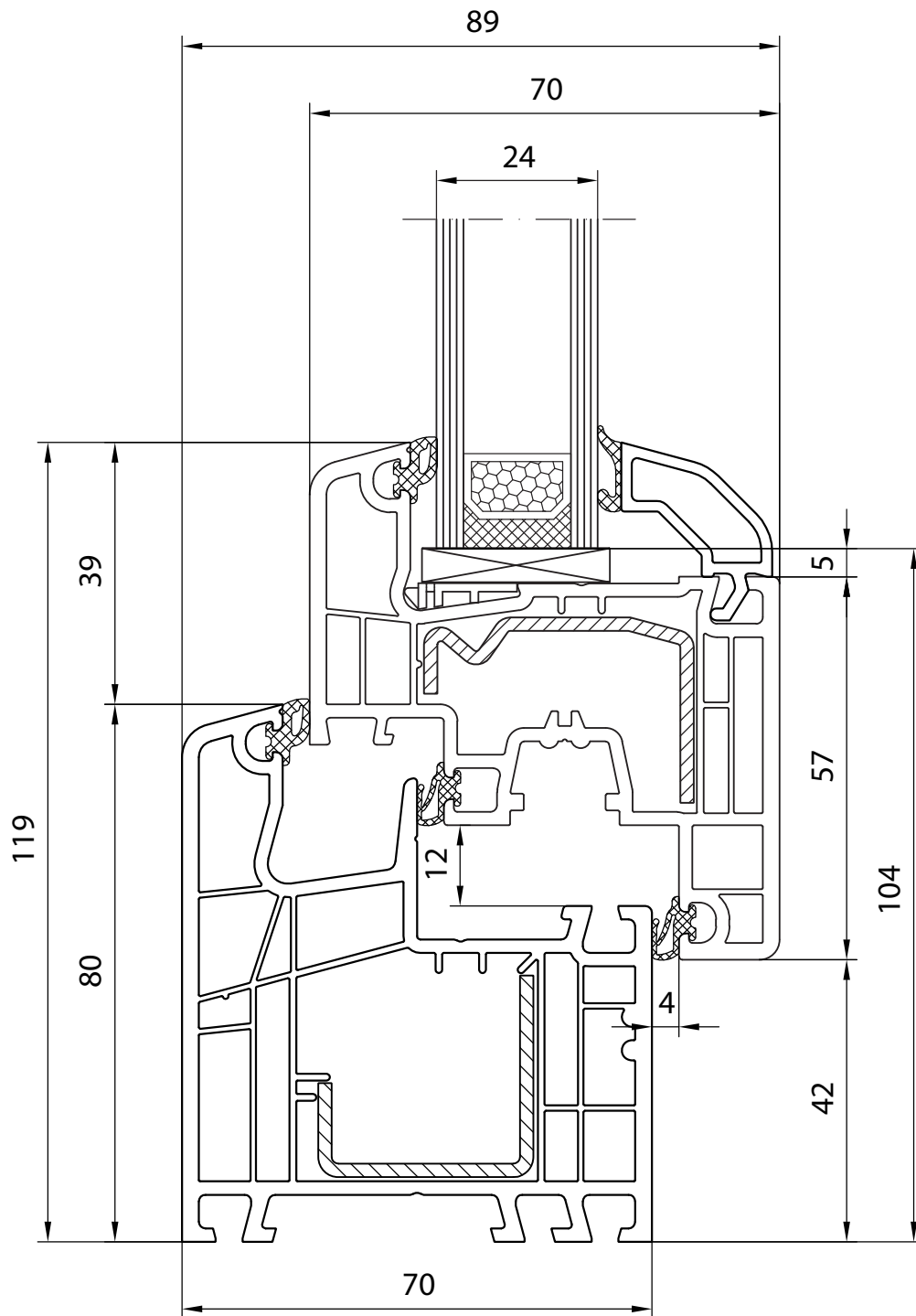

Skrzydło Classic-line



Ouvrant Classic-line



Vleugel Classic-line



Flügel Classic-line



Ante Classic-line



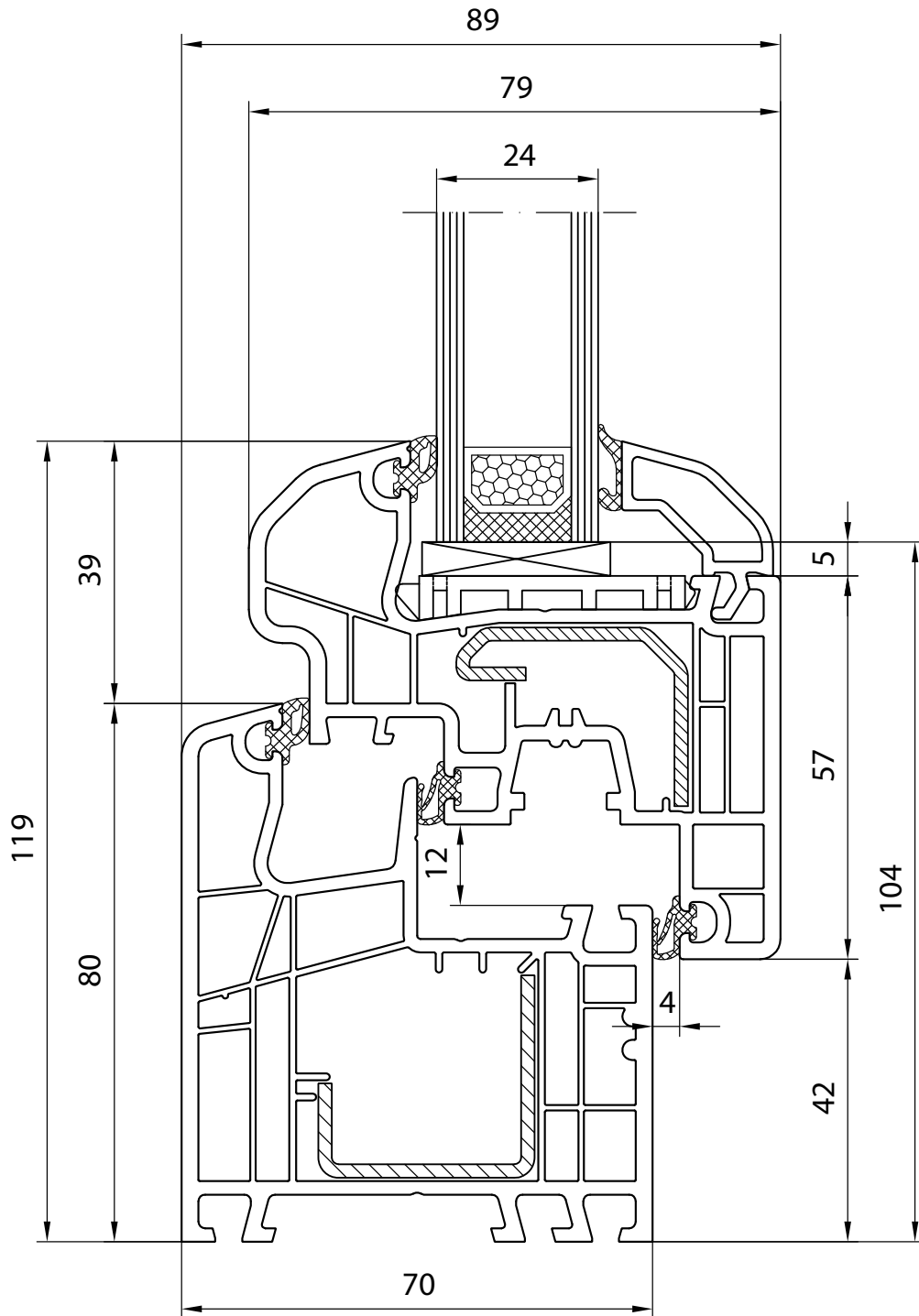

-  Skrzydło Round-line
-  Ouvrant Round-line
-  Vleugel Round-line
-  Flügel Round-line
-  Ante Round-line



IDEAL 5000

150x03 - 150x30

**OKO
OKNA**

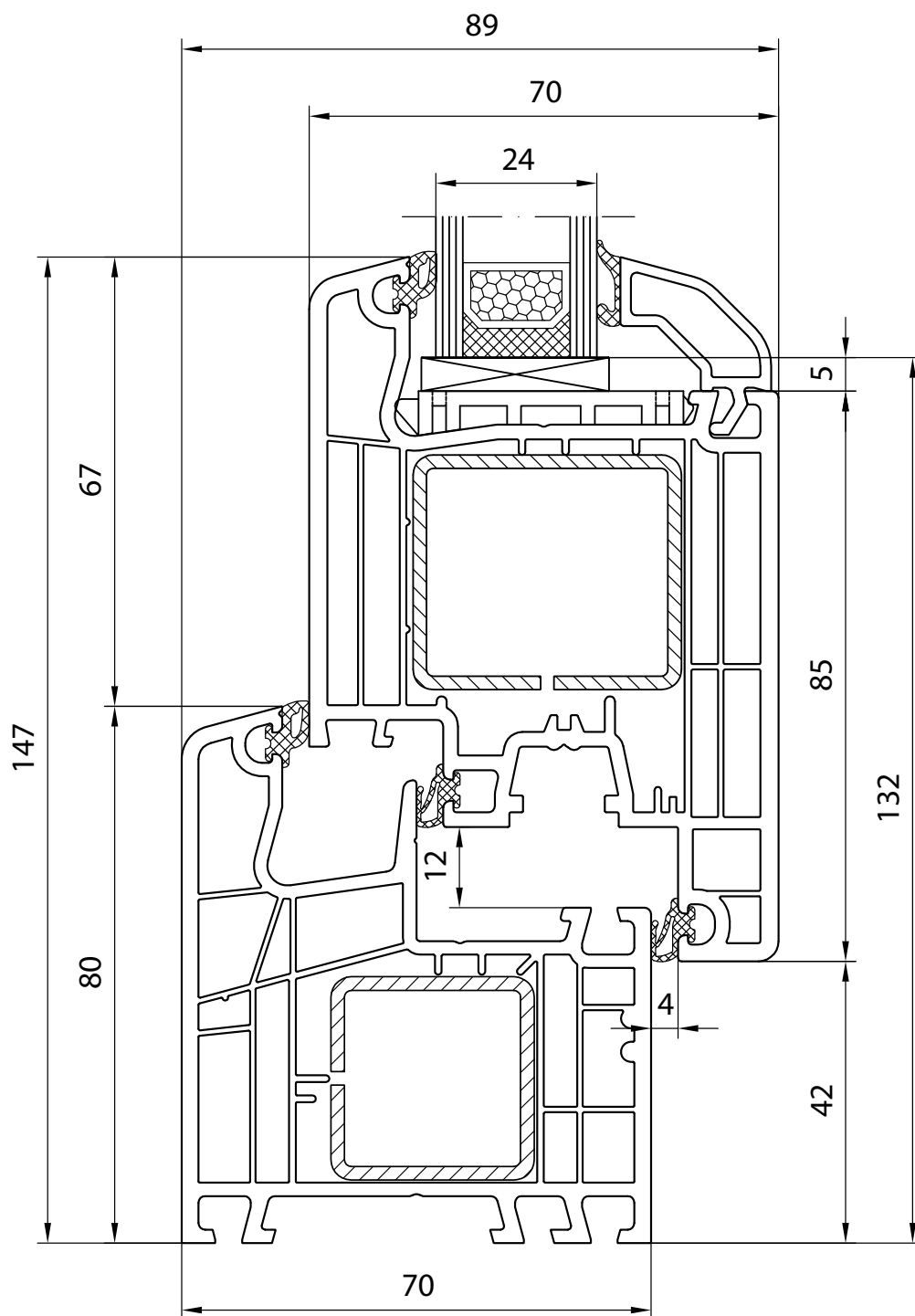

Drzwi wejściowe, otwierane do wewnątrz

Porte d'entrée, ouverture vers l'intérieur





Deur naar binnen opendraaiend

Eingangstür nach Innen öffnend

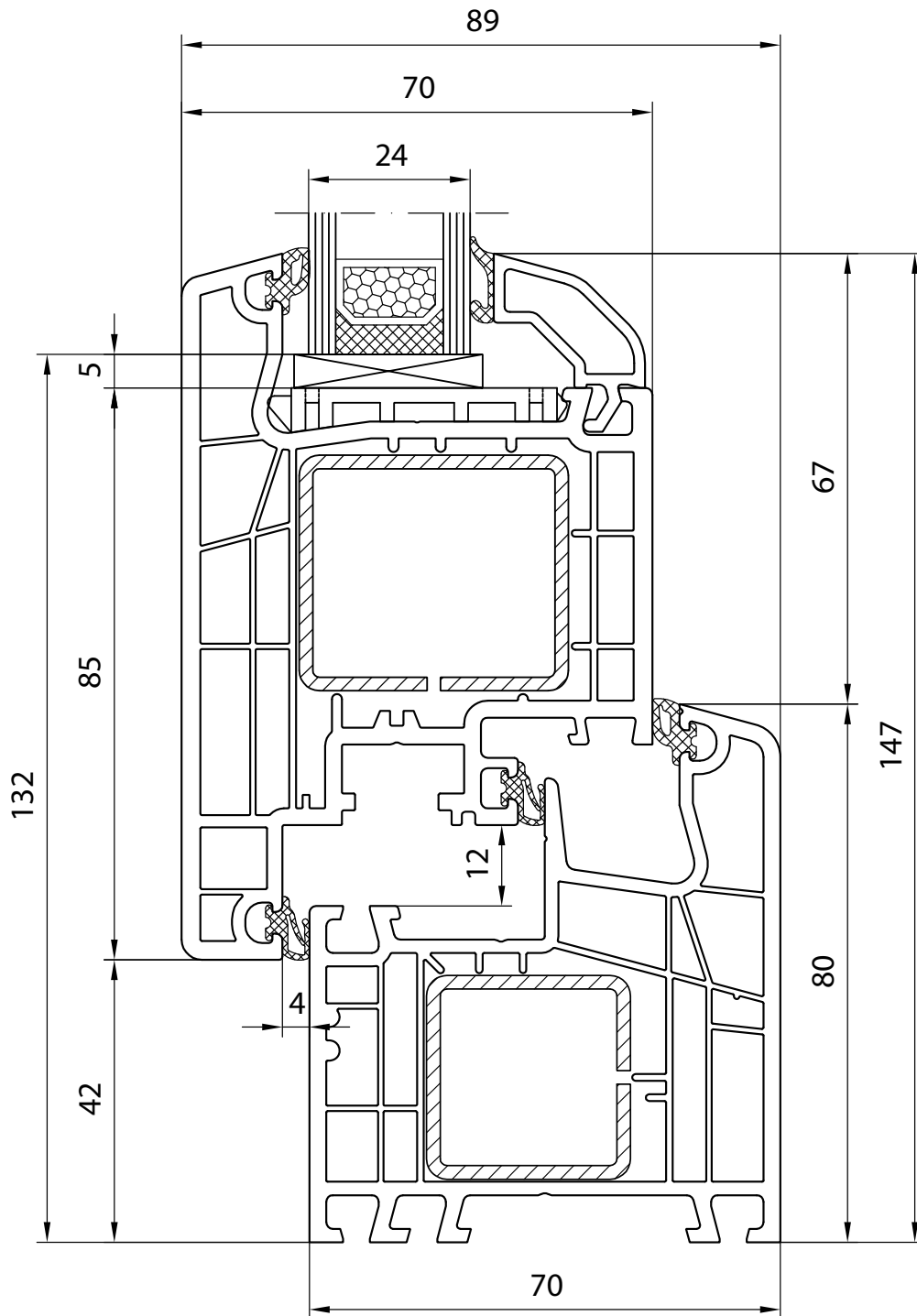
Porta d'ingresso, l'apertura verso interno





-  Drzwi wejściowe, otwierane na zewnątrz
-  Porte d'entrée, ouverture vers l'extérieur
-  Deur naar buiten opendraaiend
-  Eingangstür nach Aussen öffnend
-  Porta d'ingresso, l'apertura verso esterno

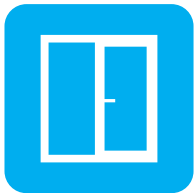

IDEAL 5000

150x03

**ЕКО
ОКНА**

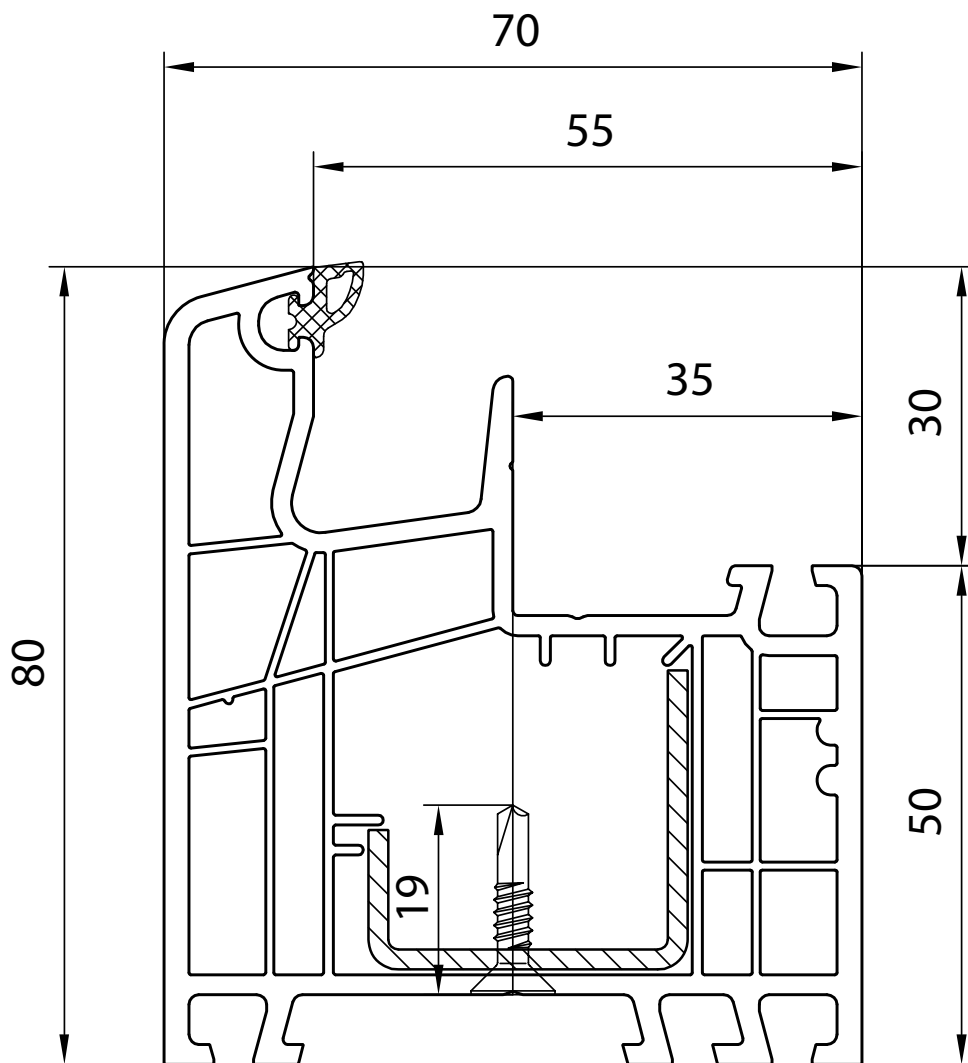

Szklenie stałe w ramie





Dormant fixe

Vast kader

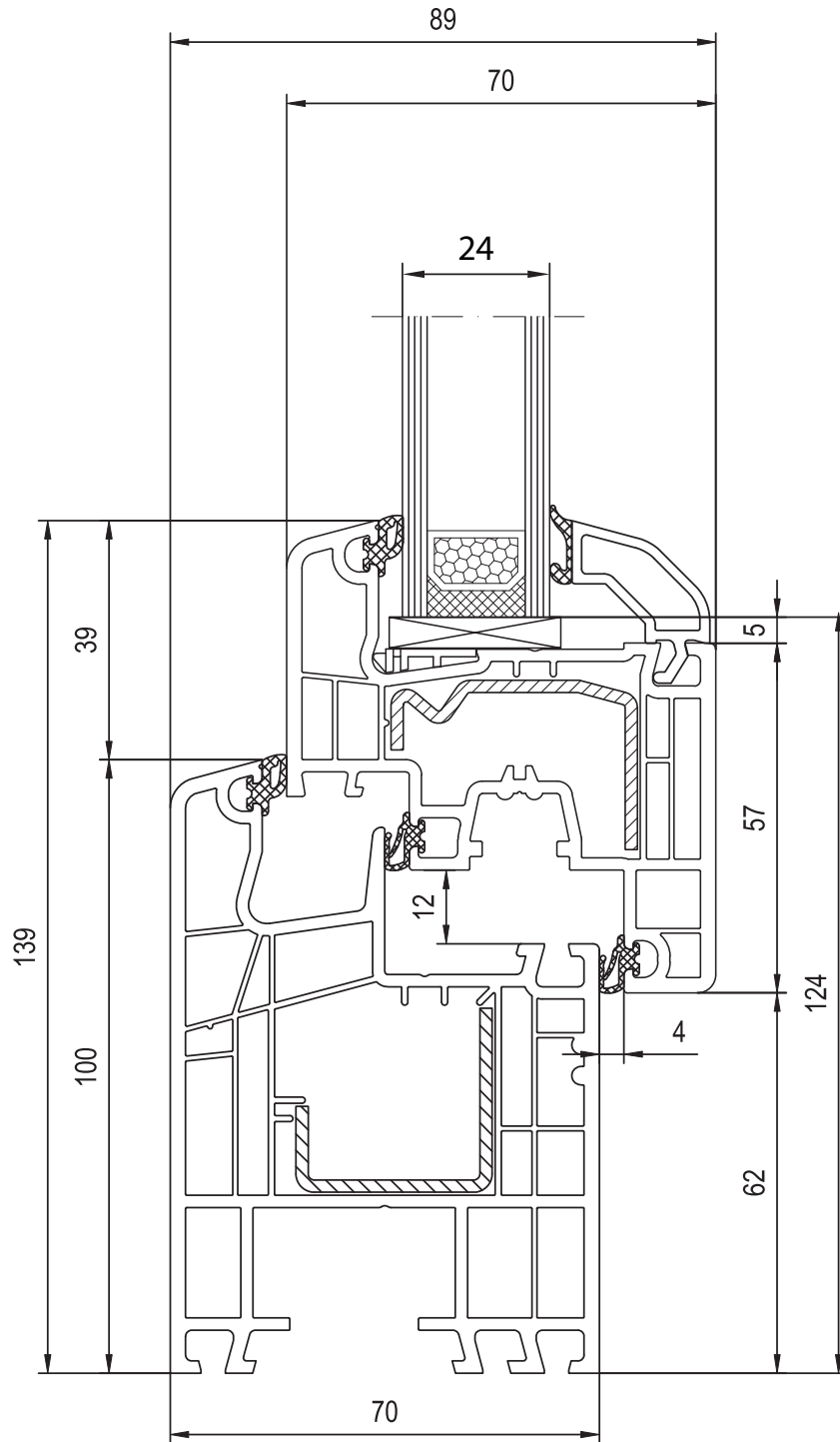
Fest im Rahmen

Serramento fisso



-  Rama 100 mm ze skrzydłem okiennym Classic-line
-  Dormant 100 mm avec ouvrant de fenêtre Classic-line
-  Kader 100 mm met raam vleugel Classic-line
-  Rahmen 100 mm mit Fensterflügel Classic-line
-  Telaio 100 mm con anta finestra Classic-line

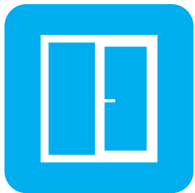

IDEAL 5000

150x04 - 150x26

**OKO
OKNA**

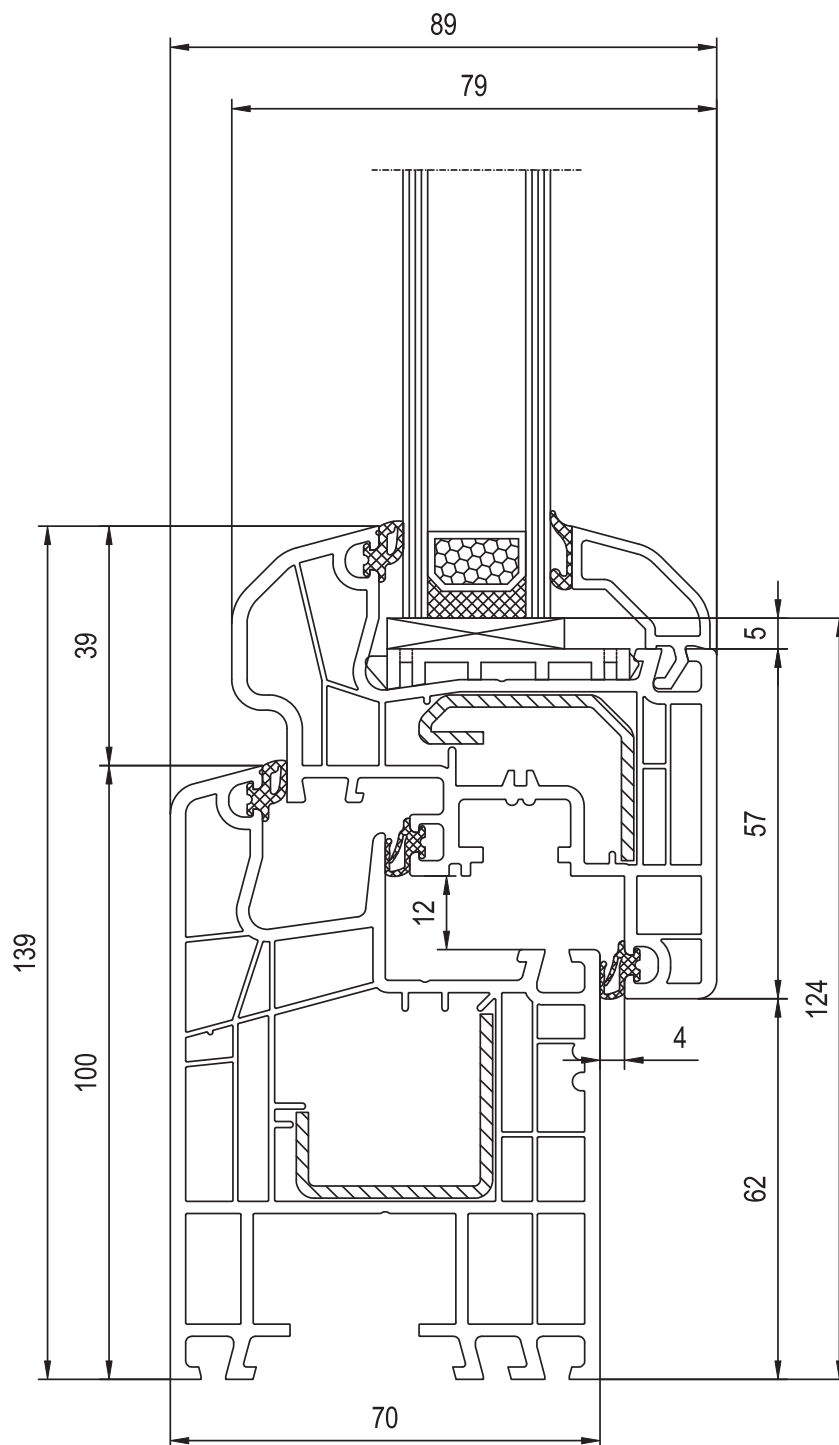

Rama 100 mm ze skrzydłem okiennym Round-line

Dormant 100 mm avec ouvrant de fenêtre Round-line

Kader 100 mm met raam vleugel Round-line

Rahmen 100 mm mit Fensterflügel Round-line

Telaio 100 mm con anta finestra Round-line



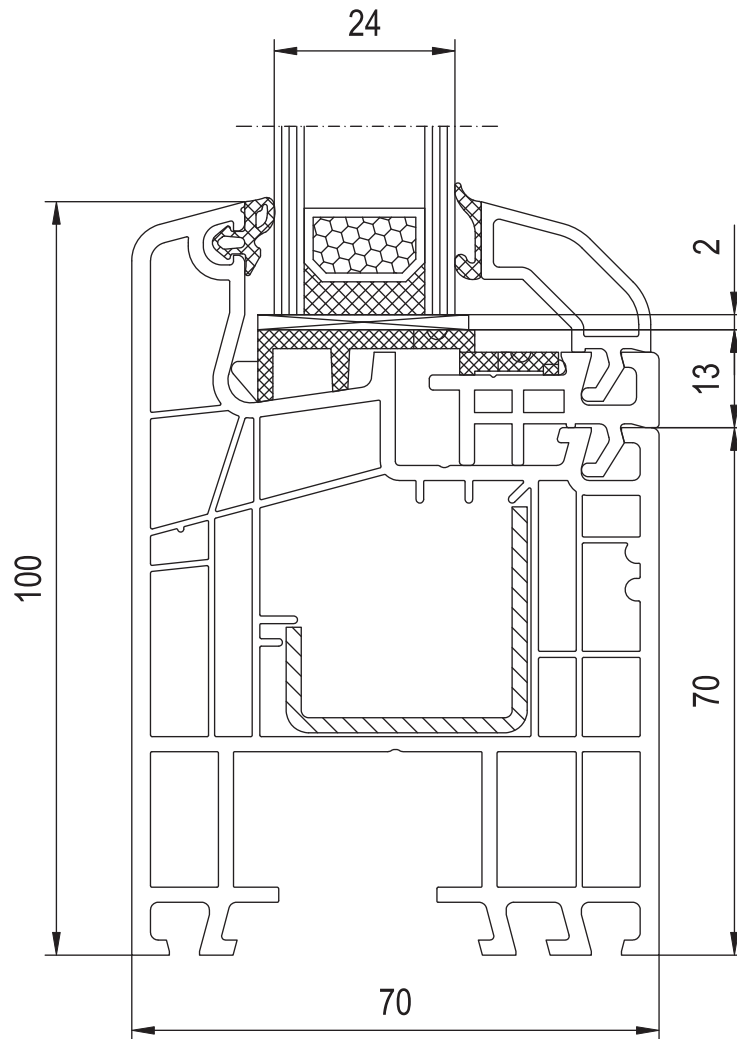

-  Rama 100 mm ze szkleniem stałym
-  Dormant 100 mm
-  Met kader 100 mm
-  Fensterverglasung 100 mm
-  Telaio da 100 mm



IDEAL 5000

150x04 - 150x30

**eko
okna**

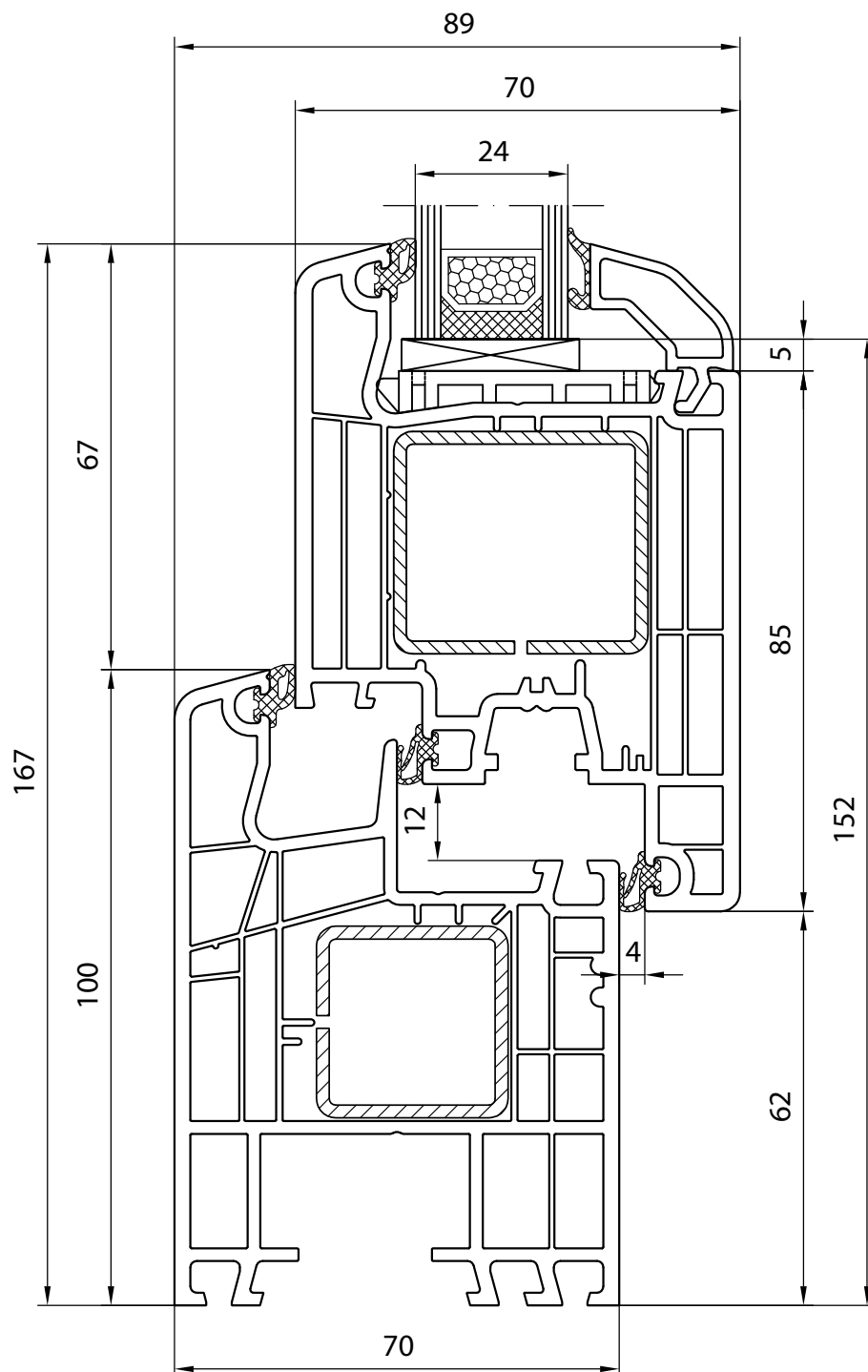

Drzwi wejściowe, otwierane do wewnątrz



Porte d'entrée, ouverture vers l'intérieur



Deur naar binnen opendraaiend









Eingangstür nach Innen öffnend

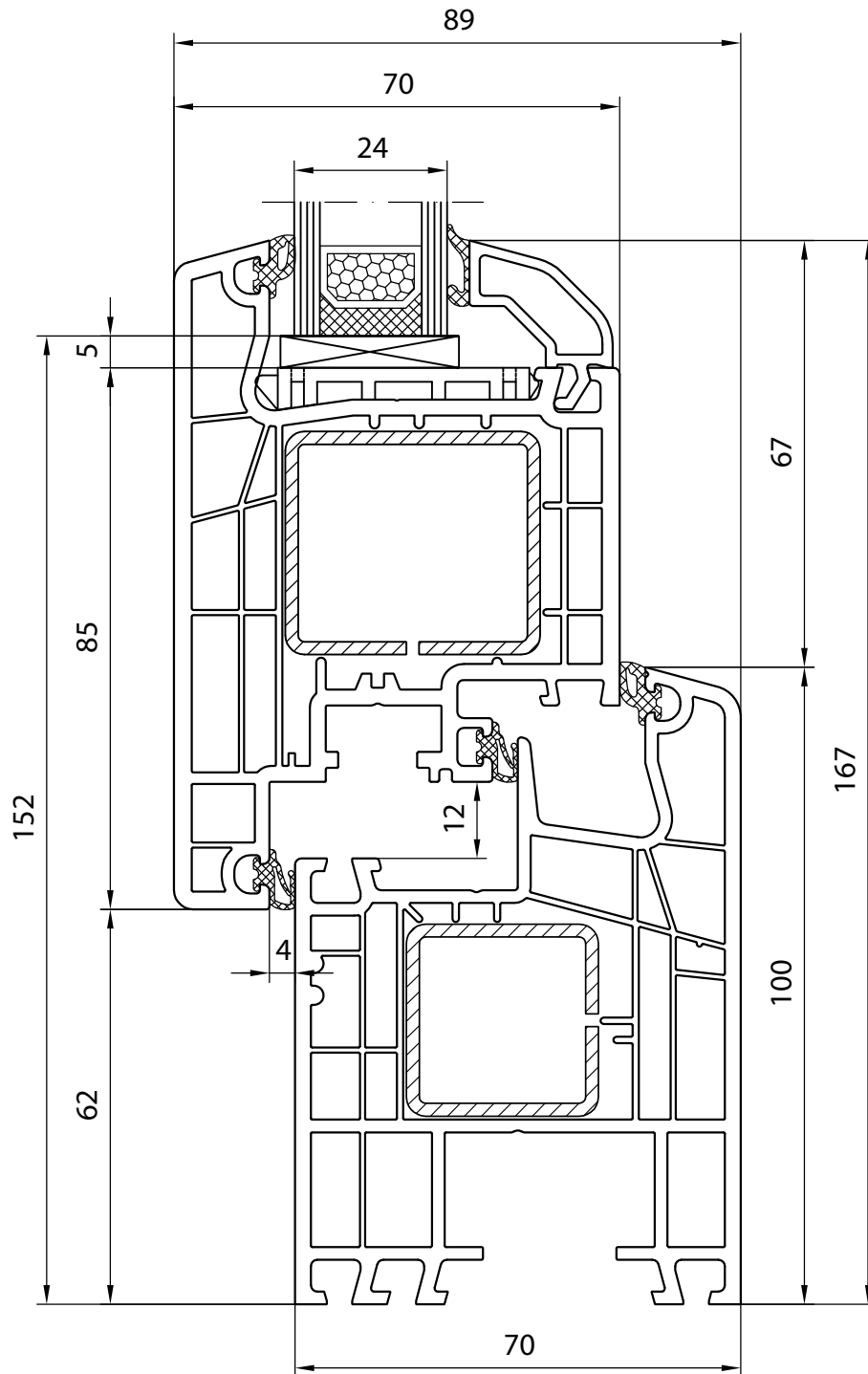

Porta d'ingresso, l'apertura verso interno





-  Drzwi wejściowe, otwierane na zewnątrz
-  Porte d'entrée, ouverture vers l'extérieur
-  Deur naar buiten opendraaiend
-  Eingangstür nach Aussen öffnend
-  Porta d'ingresso, l'apertura verso esterno

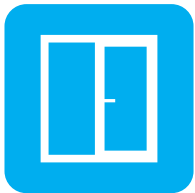

IDEAL 5000

150x10

**OKO
OKNA**

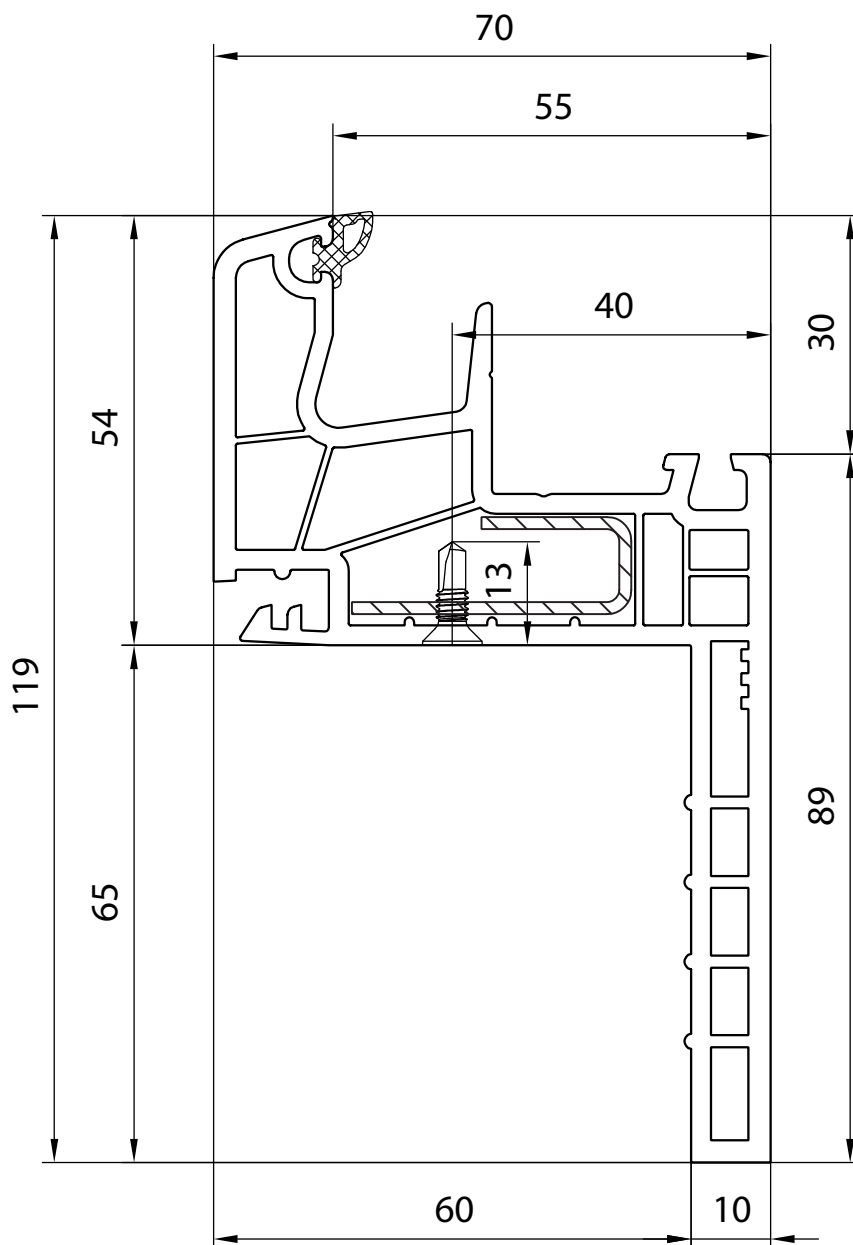

RENOWACJA - Płetwa 65 mm 





RENOVATION - Aile de 65 mm 

RENOVATIE - Lip 65 mm 

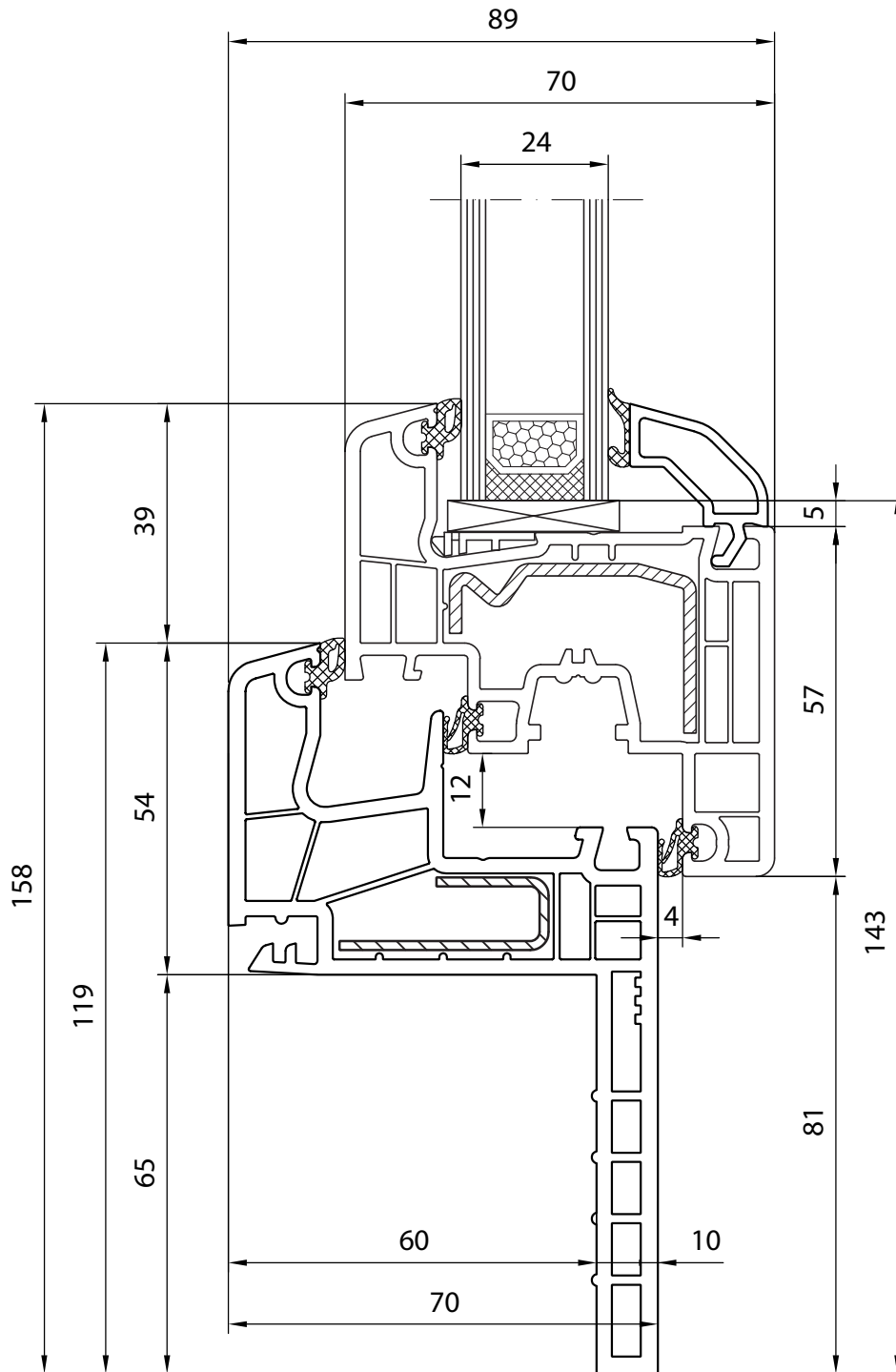
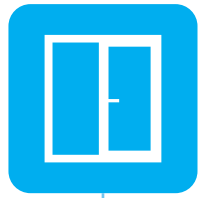
RENOVIERUNG - Flosse 65 mm 

RINNOVAZIONE - Aletta da 65 mm 



-  RENOWACJA - Płetwa 65 mm ze skrzydłem okiennym Classic-line
-  RENOVATION - Aile de 65 mm avec ouvrant de fenêtre Classic-line
-  RENOVATIE - Lip 65 mm met raam vleugel Classic-line
-  RENOVIERUNG - Flosse 65 mm mit Fensterflügel Classic-line
-  RINNOVAZIONE - Aletta da 65 mm con anta finestra Classic-line

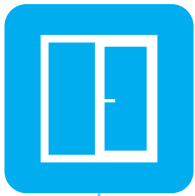

IDEAL 5000

150x10 - 150x26

**OKO
OKNA**

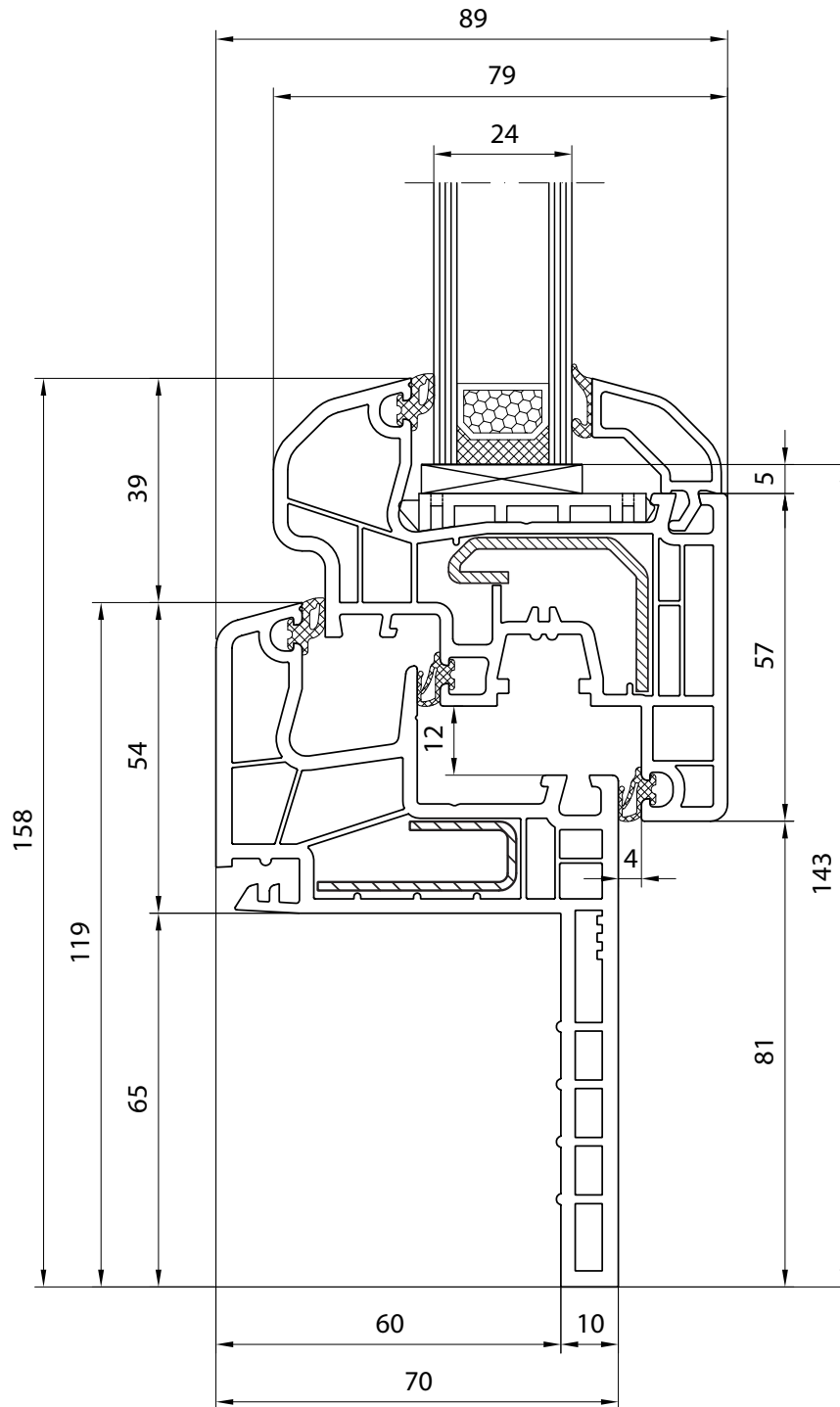

RENOWACJA - Płetwa 65 mm ze skrzydłem okiennym Round-line

RENOVATION - Aile de 65 mm avec ouvrant de fenêtre Round-line





RENOVATIE - Lip 65 mm met raam vleugel Round-line

RENOVIERUNG - Flosse 65 mm mit Fensterflügel Round-line

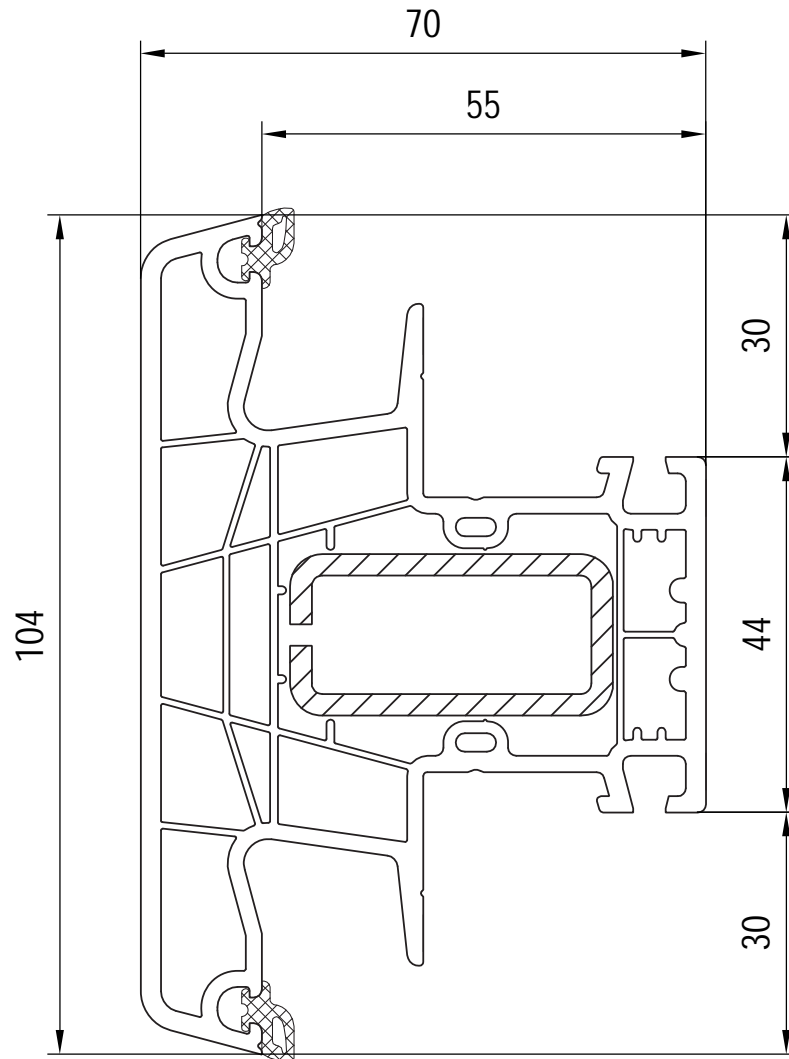
RINNOVAZIONE - Aletta da 65 mm con anta finestra Round-line





-  Słupek stały 104 mm (używany tylko w ramie)
-  Meneau fixe 104 mm (utilisé uniquement pour le dormant)
-  Vaste stijl 104 mm (wordt gebruikt alleen in het kader)
-  Fester Pfosten 104 mm (nur für Rahmen bestimmt)
-  Montante fisso 104 mm (usato solo nel telaio)



IDEAL 5000

150x20 - 150x43 - 150x20

**OKO
OKNA**

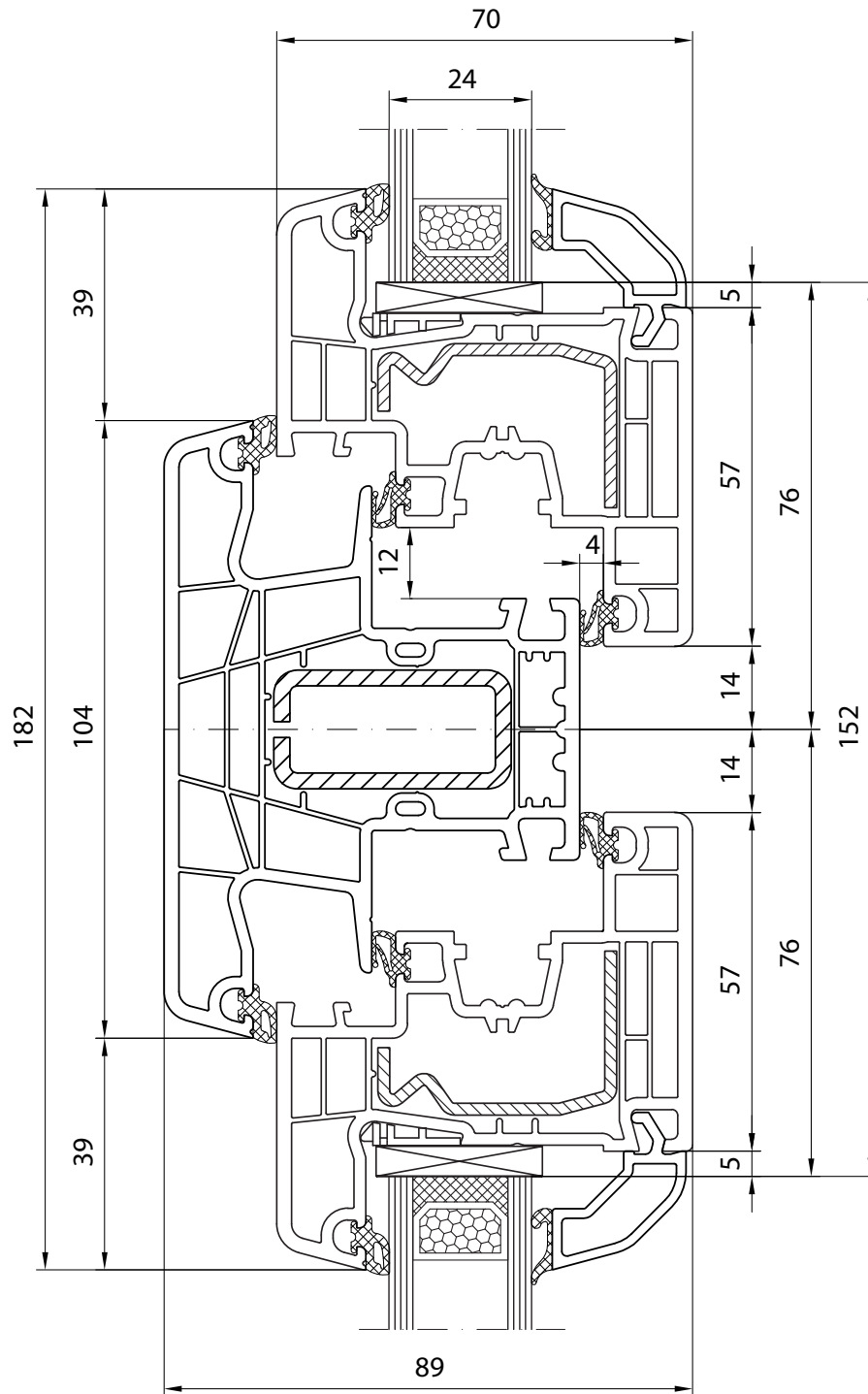

Przekrój przez słupek stały 104 mm z dwoma skrzydłami Classic-line

Coupe de meneau fixe 104 mm avec ouvrant Classic-line





Aansluiting van vleugels Classic-line met vaste stijl 104 mm

Fester Pfosten 104 mm mit Flügel Classic-line

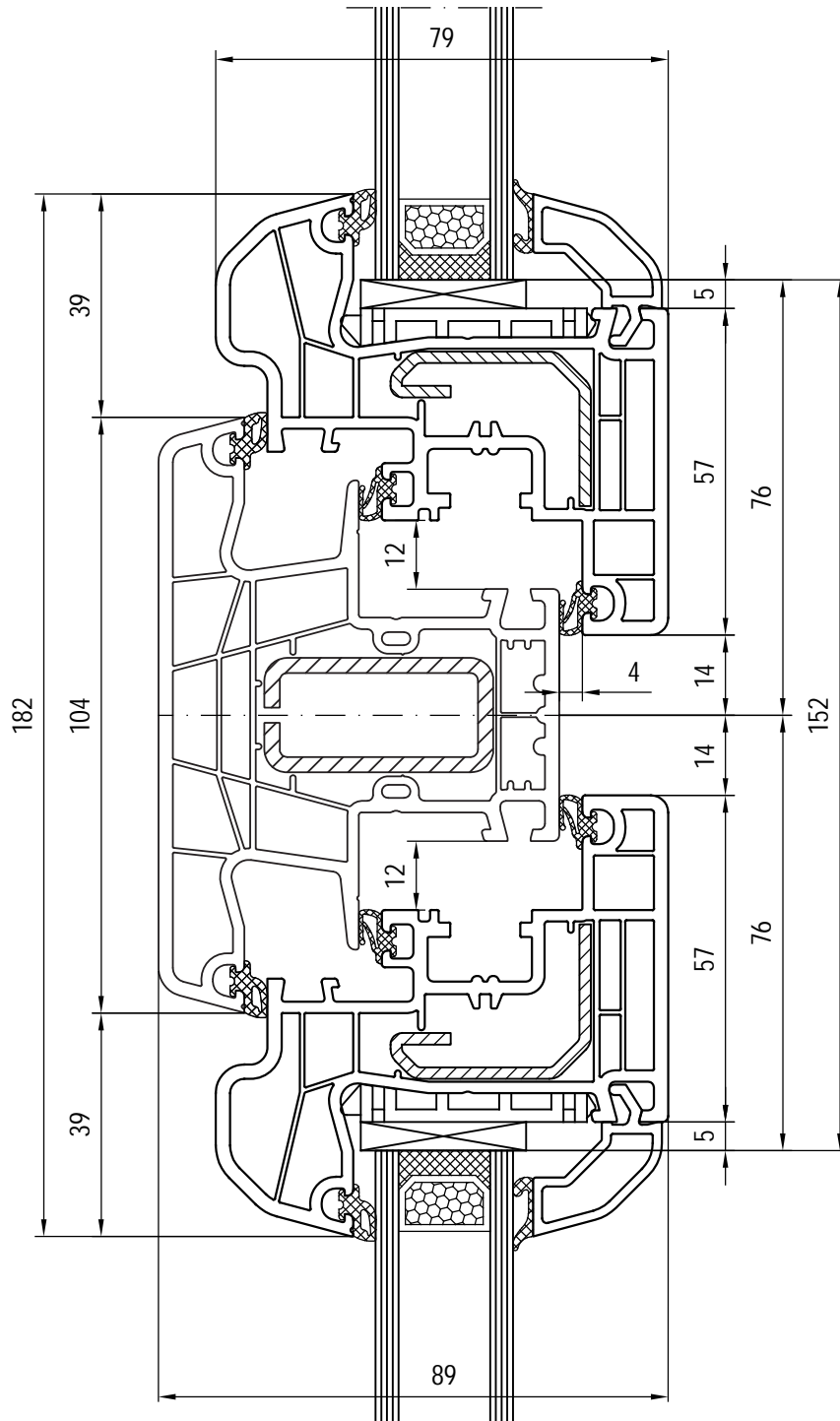
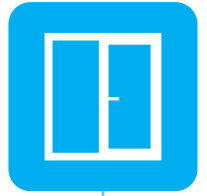
Guinzione del montante fisso 104 mm con due ante Classic-line





-  Przekrój przez słupek stały 104 mm z dwoma skrzydłami Round-line
-  Coupe de meneau fixe 104 mm avec ouvrant Round-line
-  Aansluiting van vleugels Round-line met vaste stijl 104 mm
-  Fester Pfosten 104 mm mit Flügel Round-line
-  Guinzione del montante fisso 104 mm con due ante Round-line

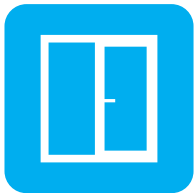

IDEAL 5000

150x65

**OKO
OKNA**

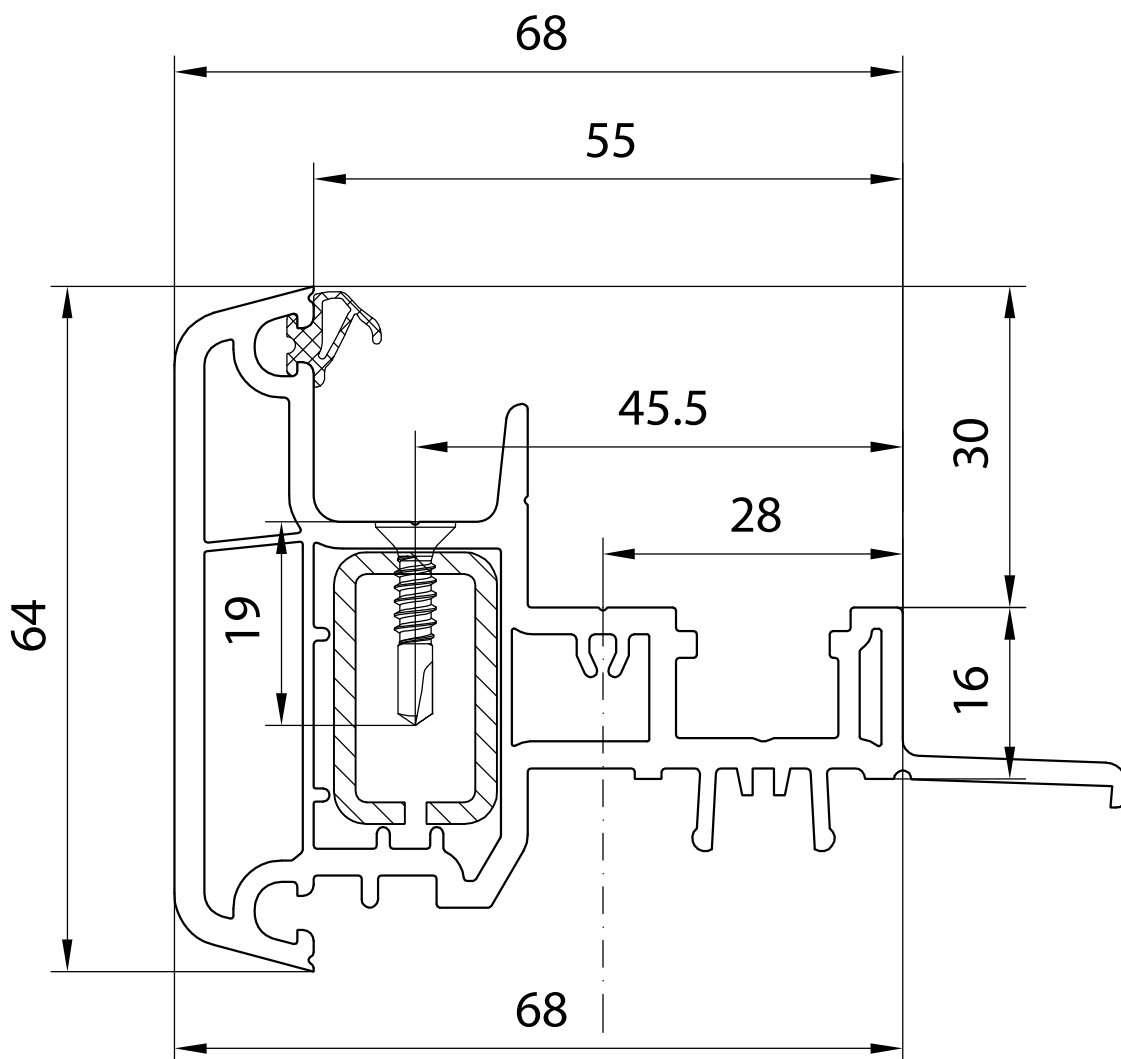

Ruchomy słupek 64 mm (wąski) 





Meneau mobile 64 mm 

Mobile paal (stulp) 64 mm 

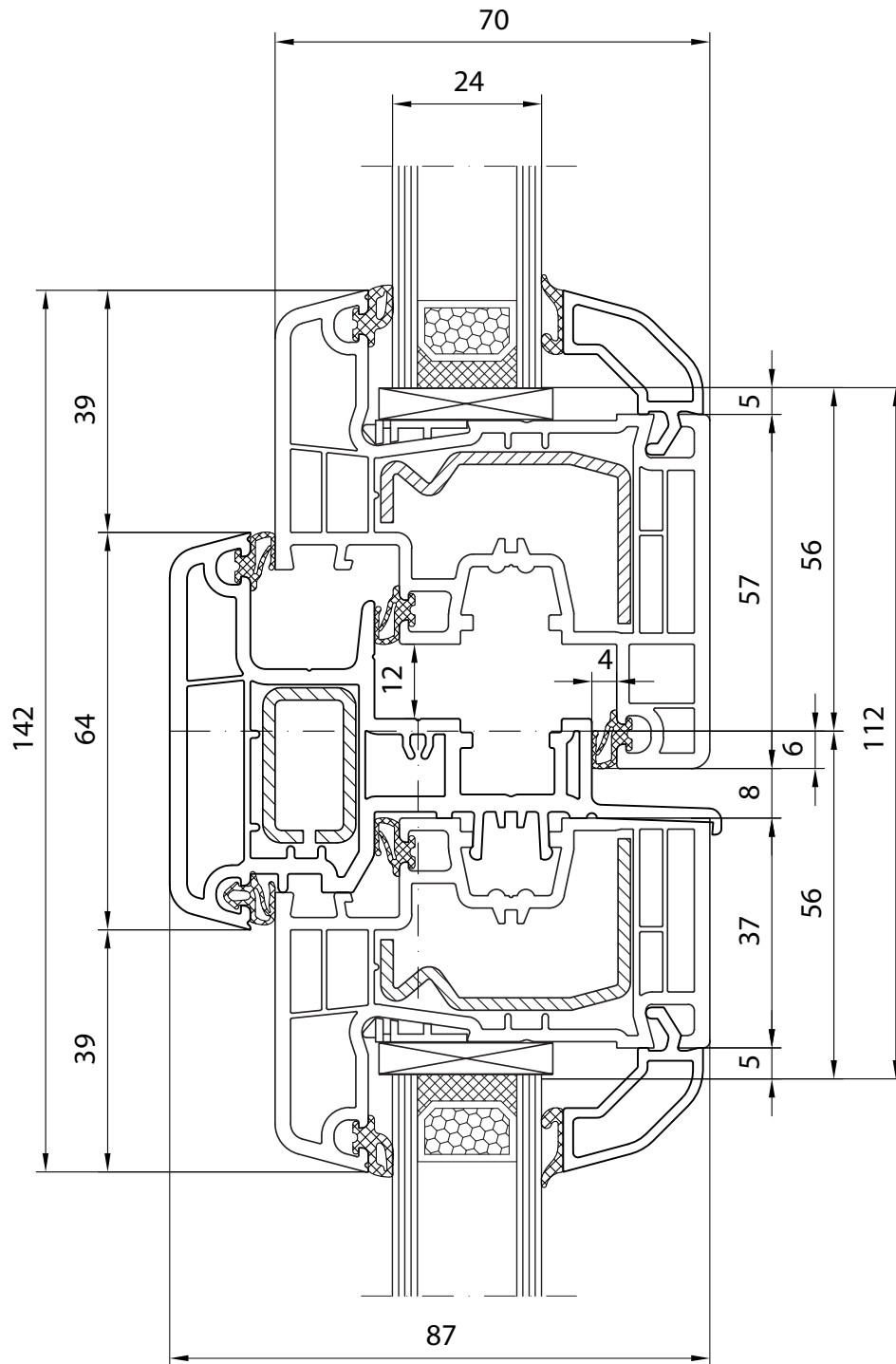
Stulp 64 mm 

Montante mobile 64 mm 



-  Przekrój przez ruchomy słupek 64 mm z dwoma skrzydłami Classic-line
-  Coupe d'ouvrants Classic-line, meneau mobile 64 mm
-  Aansluiting vleugels Classic-line met stulp 64 mm
-  Flügel Classic-line, verbunden mit Hilfe eines Stulps 64 mm
-  Giunzione delle ante Round-line con montante mobile 64 mm

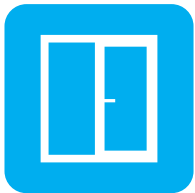

IDEAL 5000

150x26 - 150x65 - 150x26

**OKO
OKNA**

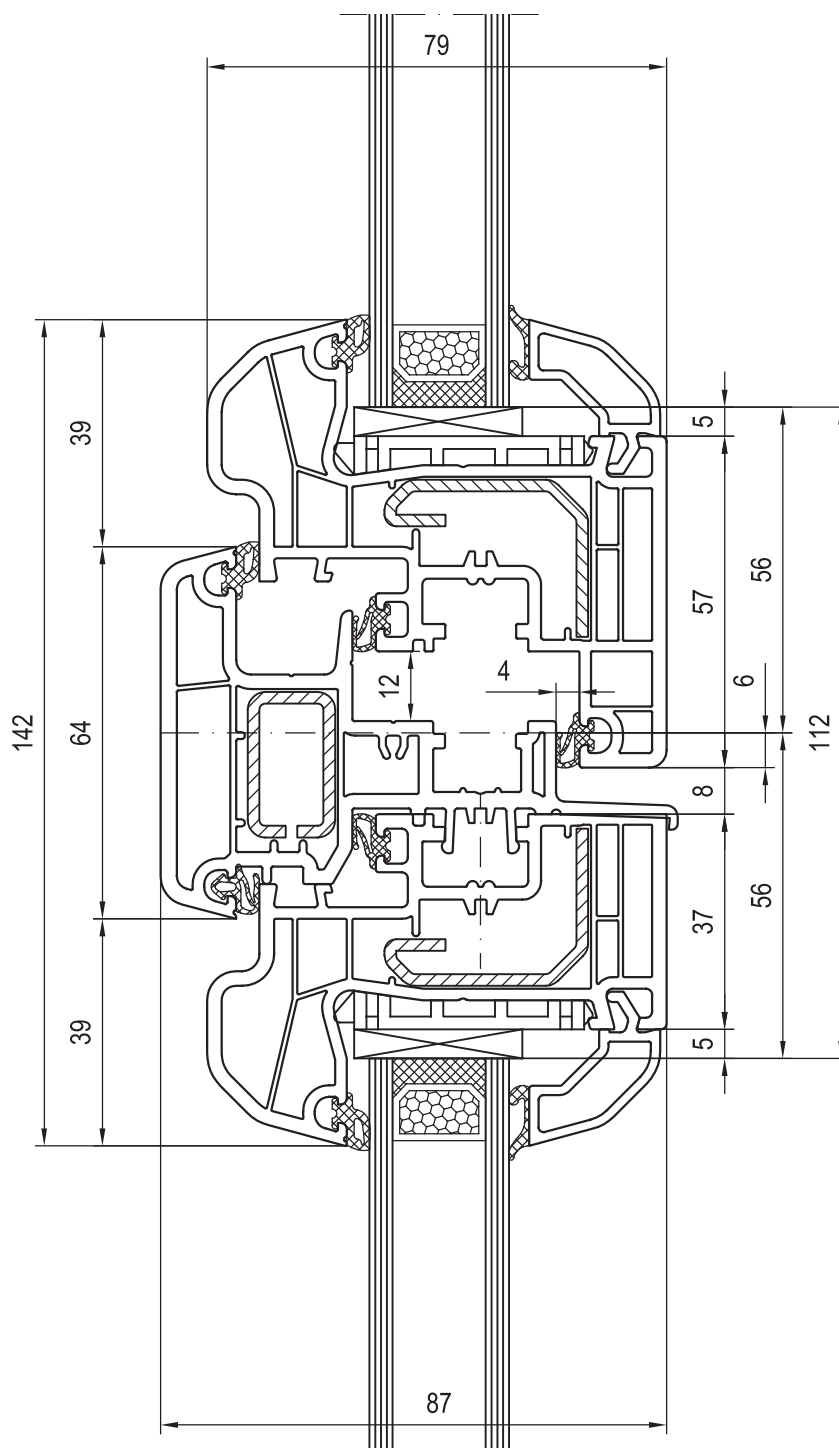

Przekrój przez ruchomy słupek 64 mm z dwoma skrzydłami Round-line

Coupe d'ouvrants Round-line, meneau mobile 64 mm





Aansluiting vleugels Round-line met stulp 64 mm

Flügel Round-line, verbunden mit Hilfe eines Stulpes 64 mm

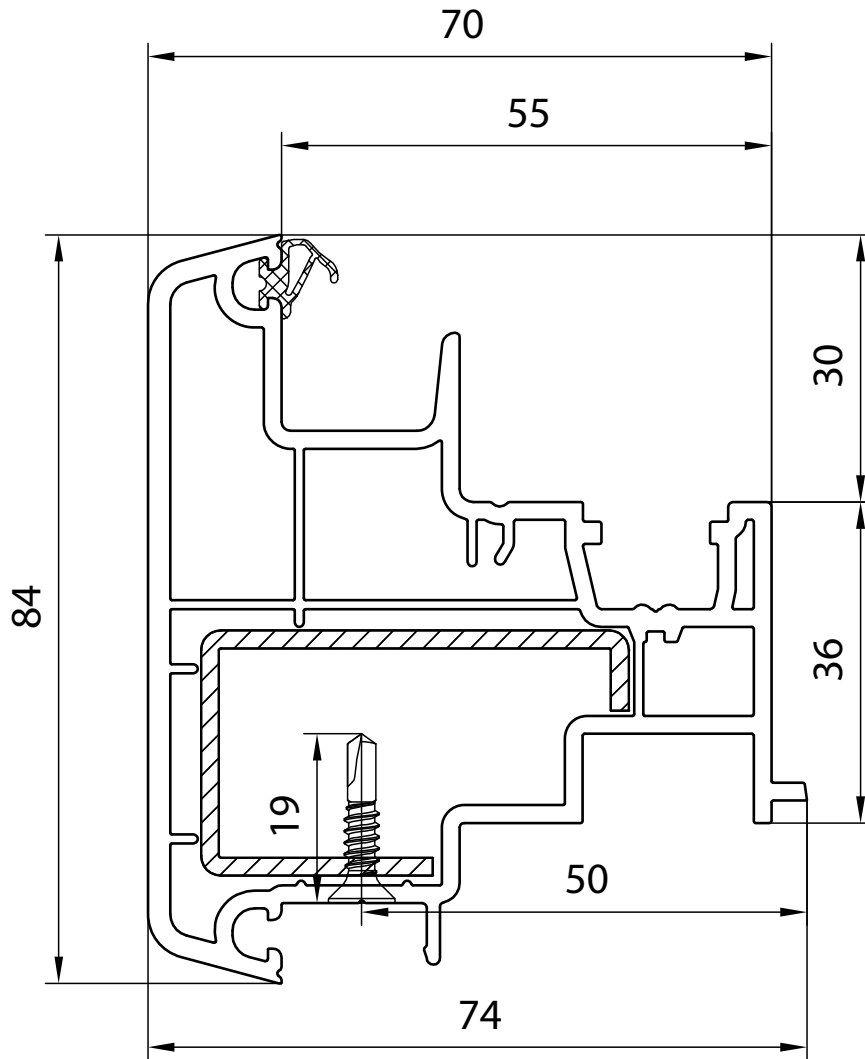
Giunzione delle ante Round-line con montante mobile 64 mm





-  Ruchomy słupek 84 mm (szeroki)
-  Meneau mobile 84 mm
-  Mobile paal (stulp) 84 mm
-  Stulp 84 mm
-  Montante mobile 84 mm

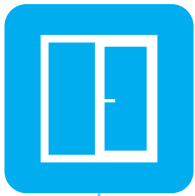

IDEAL 5000

150x20 - 150x67 - 150x20

**OKO
OKNA**

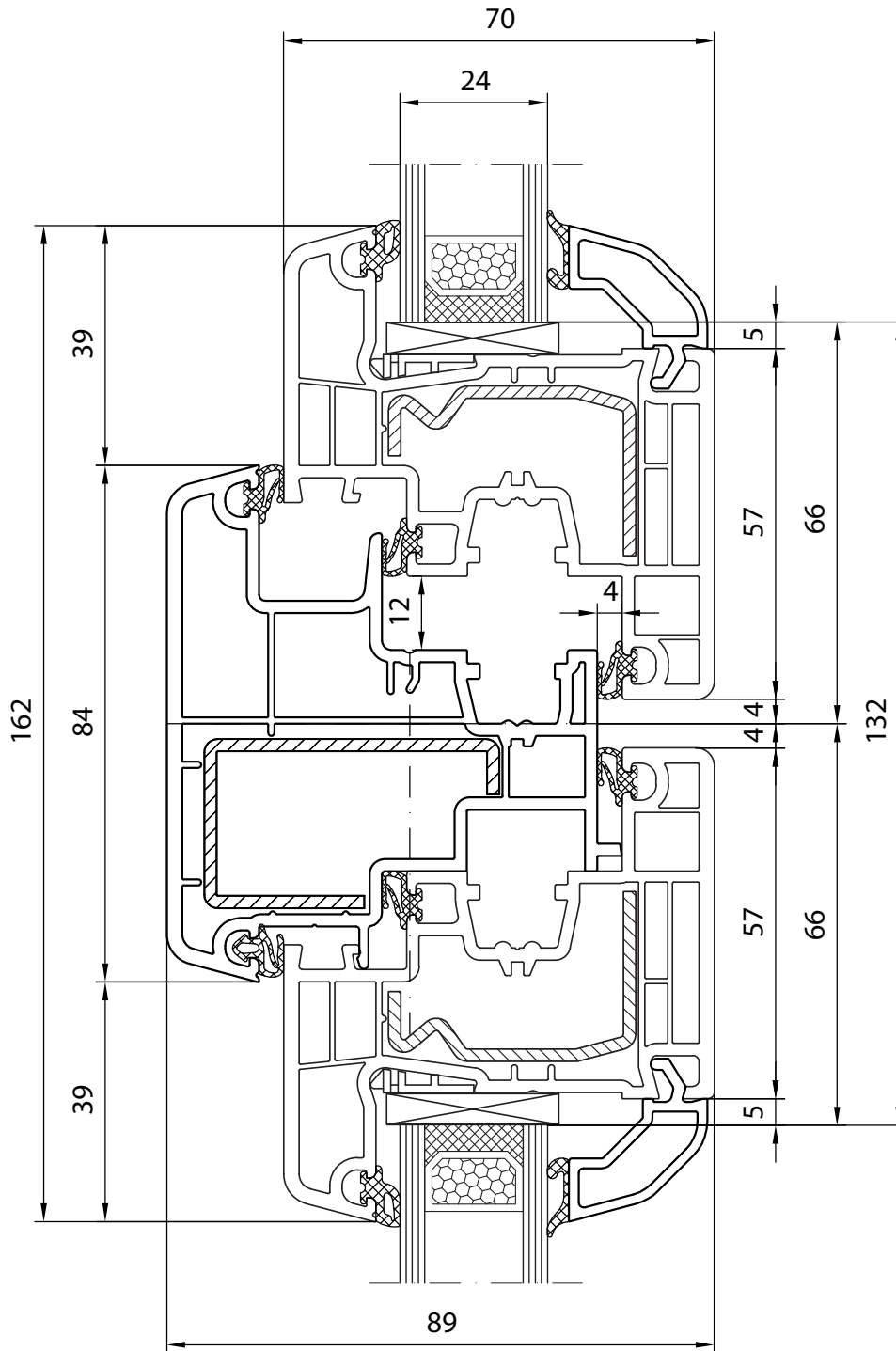

Przekrój przez ruchomy słupek 84 mm z dwoma skrzydłami Classic-line

Coupe d'ouvrants Classic-line, meneau mobile 84 mm





Aansluiting vleugels Classic-line met stulp 84 mm

Flügel Classic-line, verbunden mit Hilfe eines Stulp 84 mm

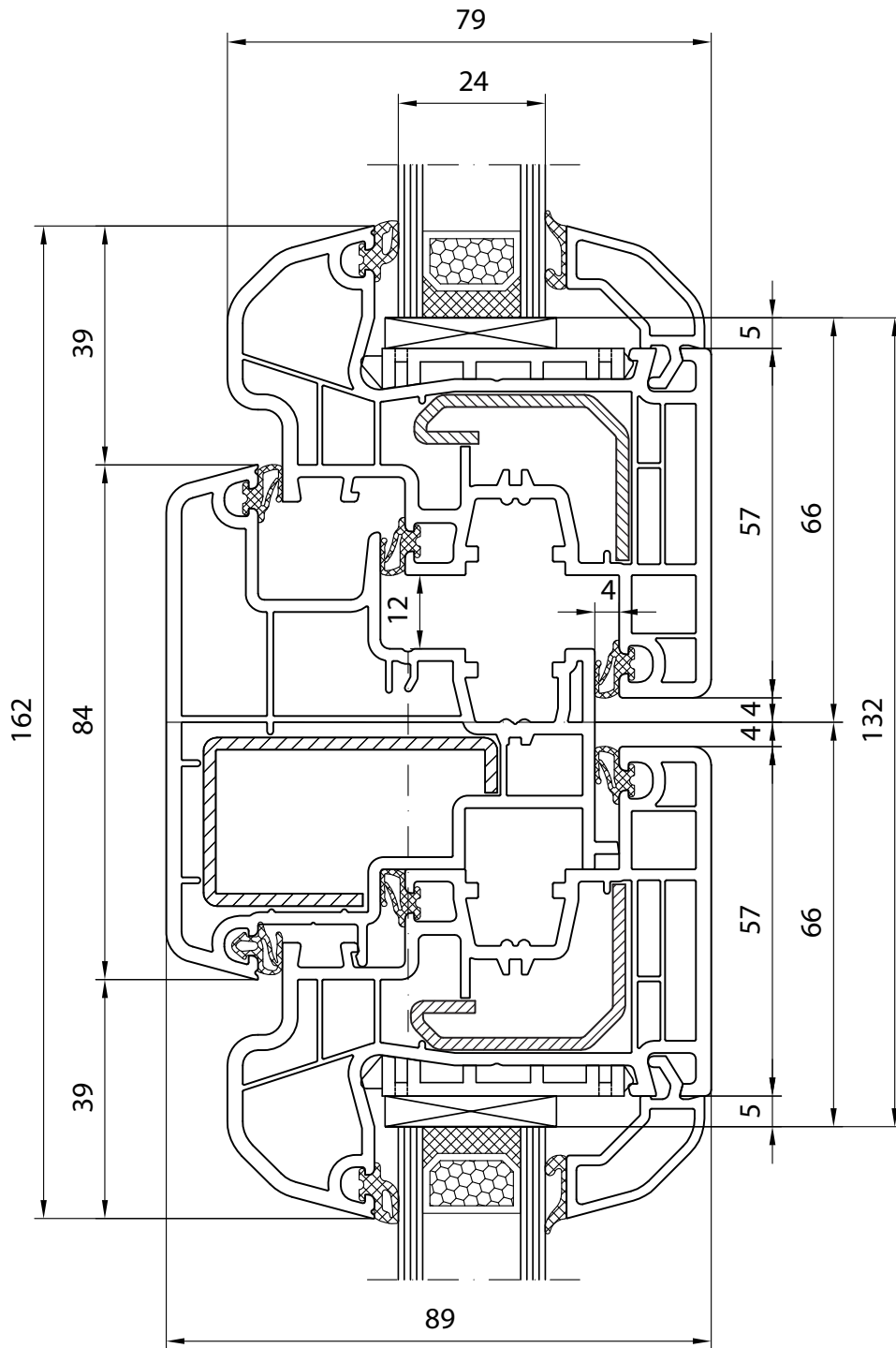
Giunzione delle ante Classic-line con montante mobile 84 mm





-  Przekrój przez ruchomy słupek 84 mm z dwoma skrzydłami Round-line
-  Coupe d'ouvrants Round-line, meneau mobile 84 mm
-  Aansluiting vleugels Round-line met stulp 84 mm
-  Flügel Round-line, verbunden mit Hilfe eines Stulps 84 mm
-  Giunzione delle ante Round-line con montante mobile 84 mm

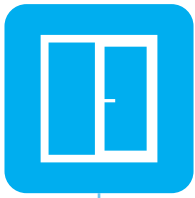

IDEAL 5000

150x69 - 150x26

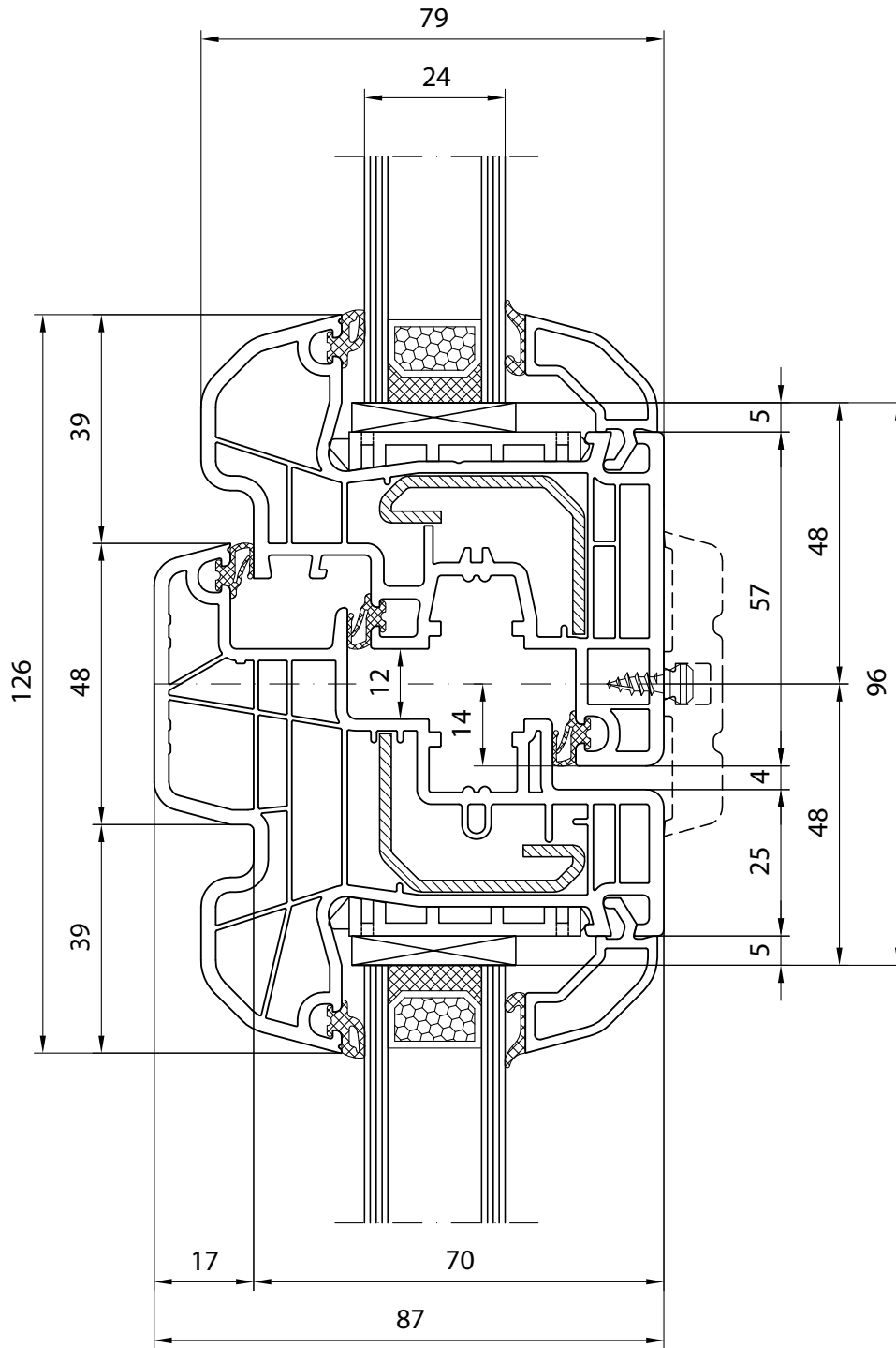

Klamka centralna (tylko białe)



Battue centrée (blanc)



Centrale kruk (wit)



Zentrale Olive (weiß)



Maniglia centrale (bianco)



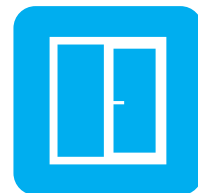

IDEAL 8000 Round-line

IDEAL 8000 Classic-line



IDEAL 8000 | 6 komór | 3 uszczelki

Stal pokazana na rysunku może nie być stalą stosowaną standardowo.



IDEAL 8000 | 6 chambres | 3 joints

Renfort en acier présenté sur le dessin ci-dessus est en option.



IDEAL 8000 | 6 kamers | 3 afdichtingen

Staal die u op de tekening ziet, is niet standaard.



IDEAL 8000 | 6 Kammern | 3 Dichtungen

Der angewendete Stahlkern kann von dem abgebildeten Kern abweichen.



IDEAL 8000 | 6 camere | 3 guarnizioni

L'acciaio presentato sul disegno può essere un acciaio non standard.

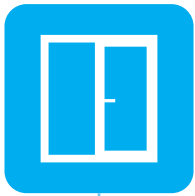

IDEAL 8000

180x05 - 180x20

**OKO
OKNA**

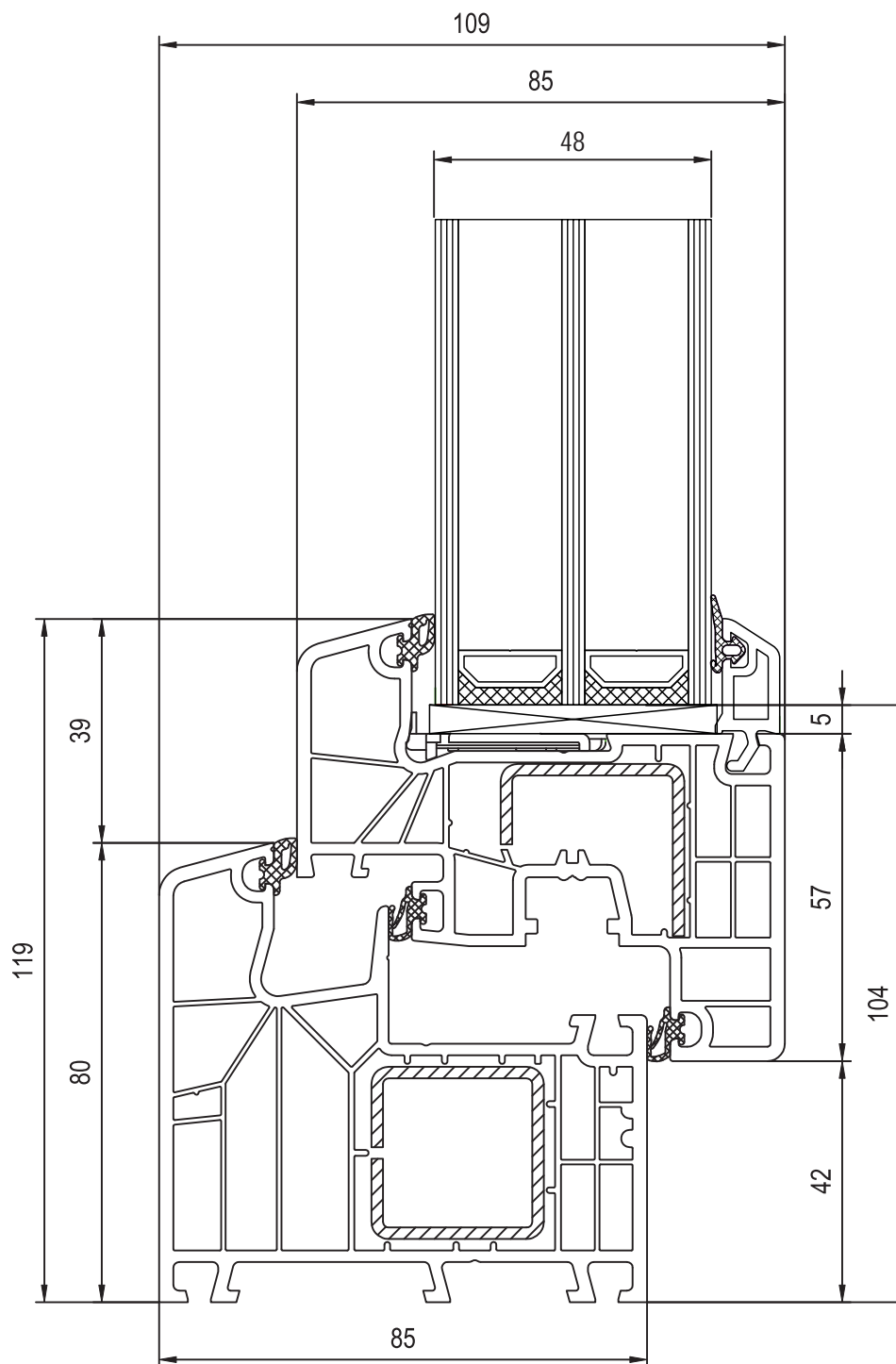

Profil Classic-line 





Profil Classic-line 

Profil Classic-line 

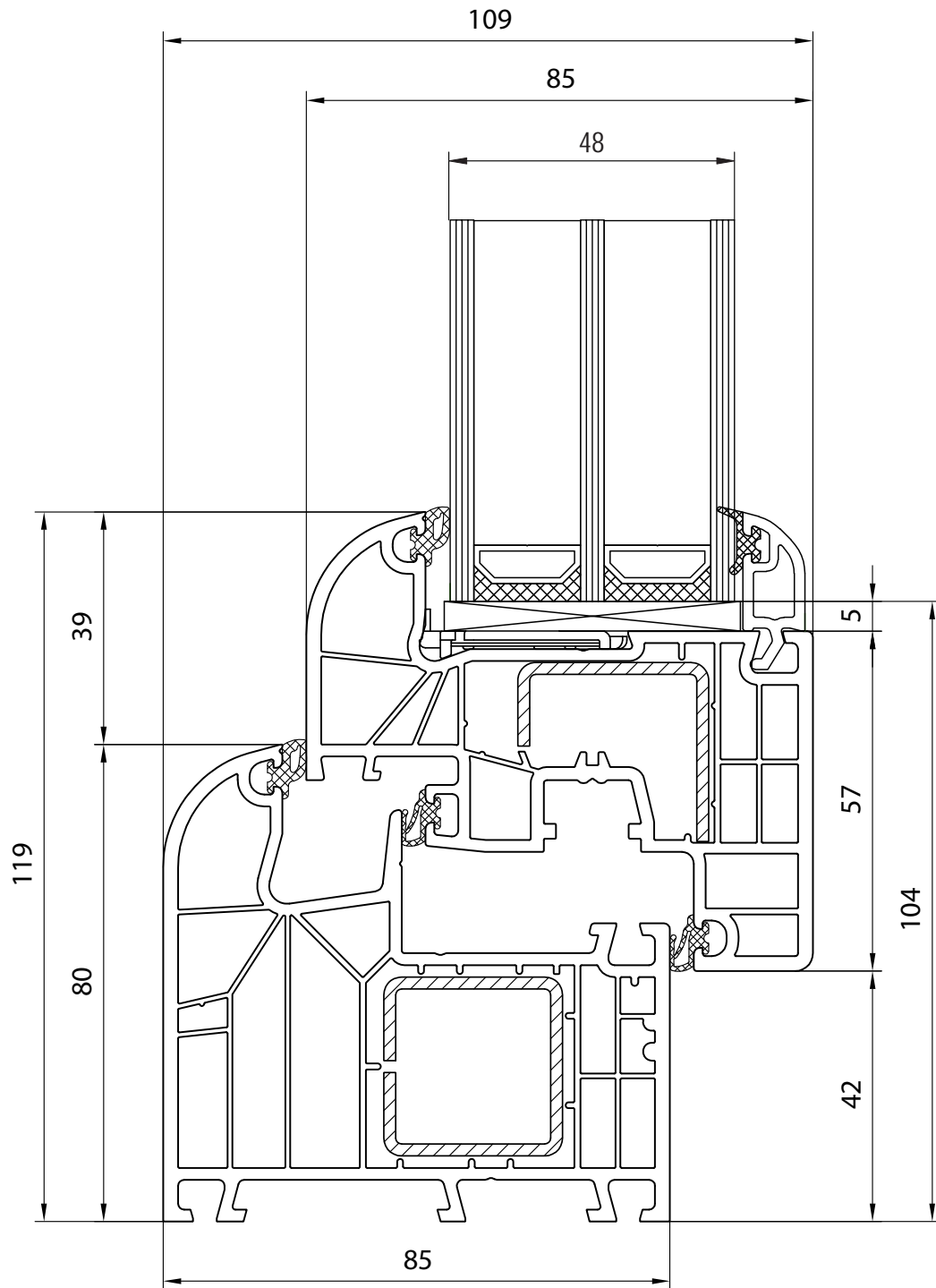
Profil Classic-line 

Profilo Classic-line 



-  Profil Round-line
-  Profil Round-line
-  Profil Round-line
-  Profil Round-line
-  Profilo Round-line

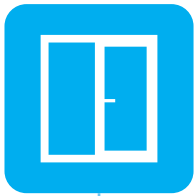

IDEAL 8000

180x05 - 180x22

**OKO
OKNA**

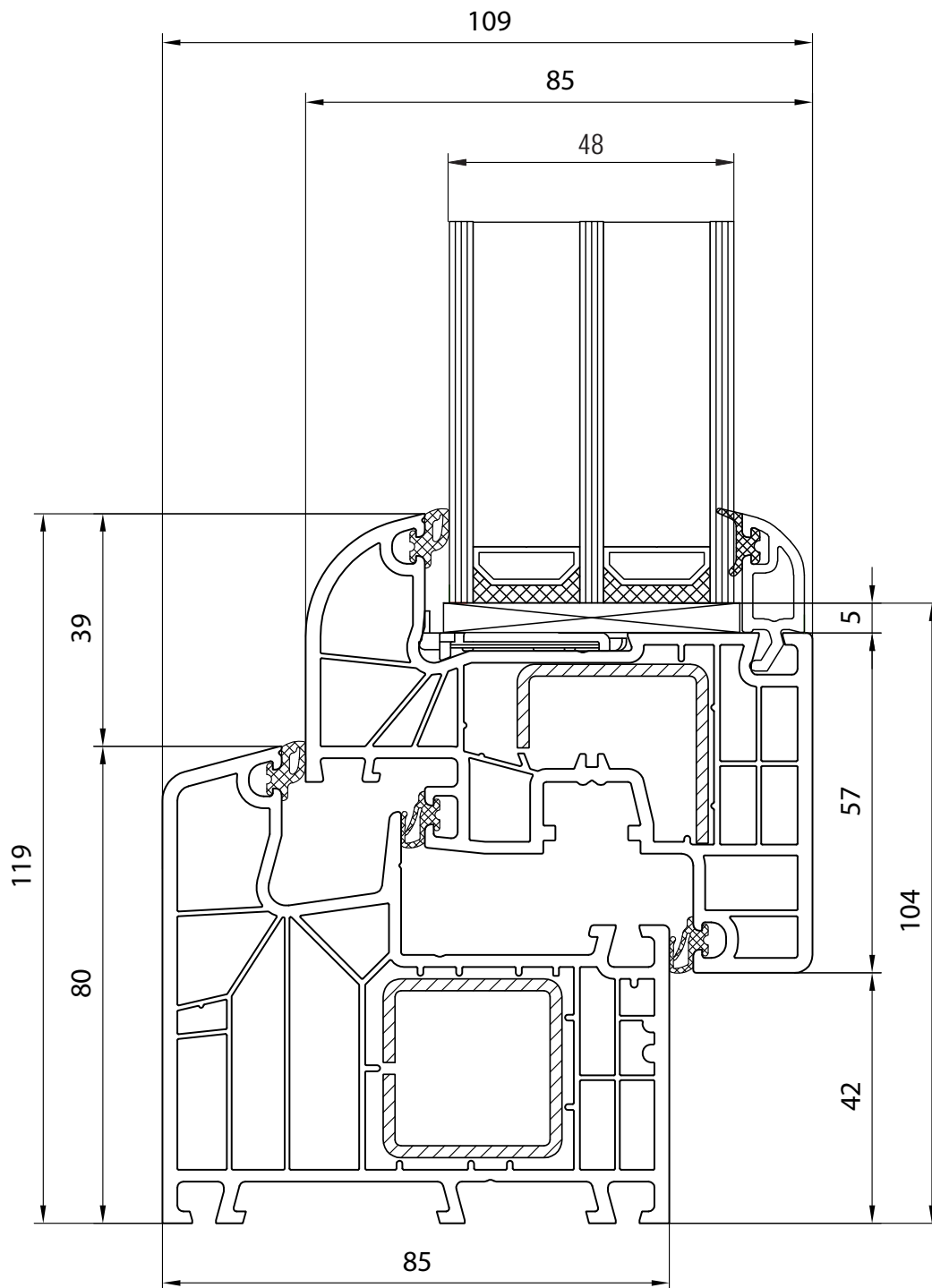

Rama Classic-line, skrzydło okienne Round-line

Dormant Classic-line, ouvrants de fenêtre Round-line





Kader Classic-line, Raamprofiel Round-line

Rahmen Classic-line, Flügelprofil Round-line

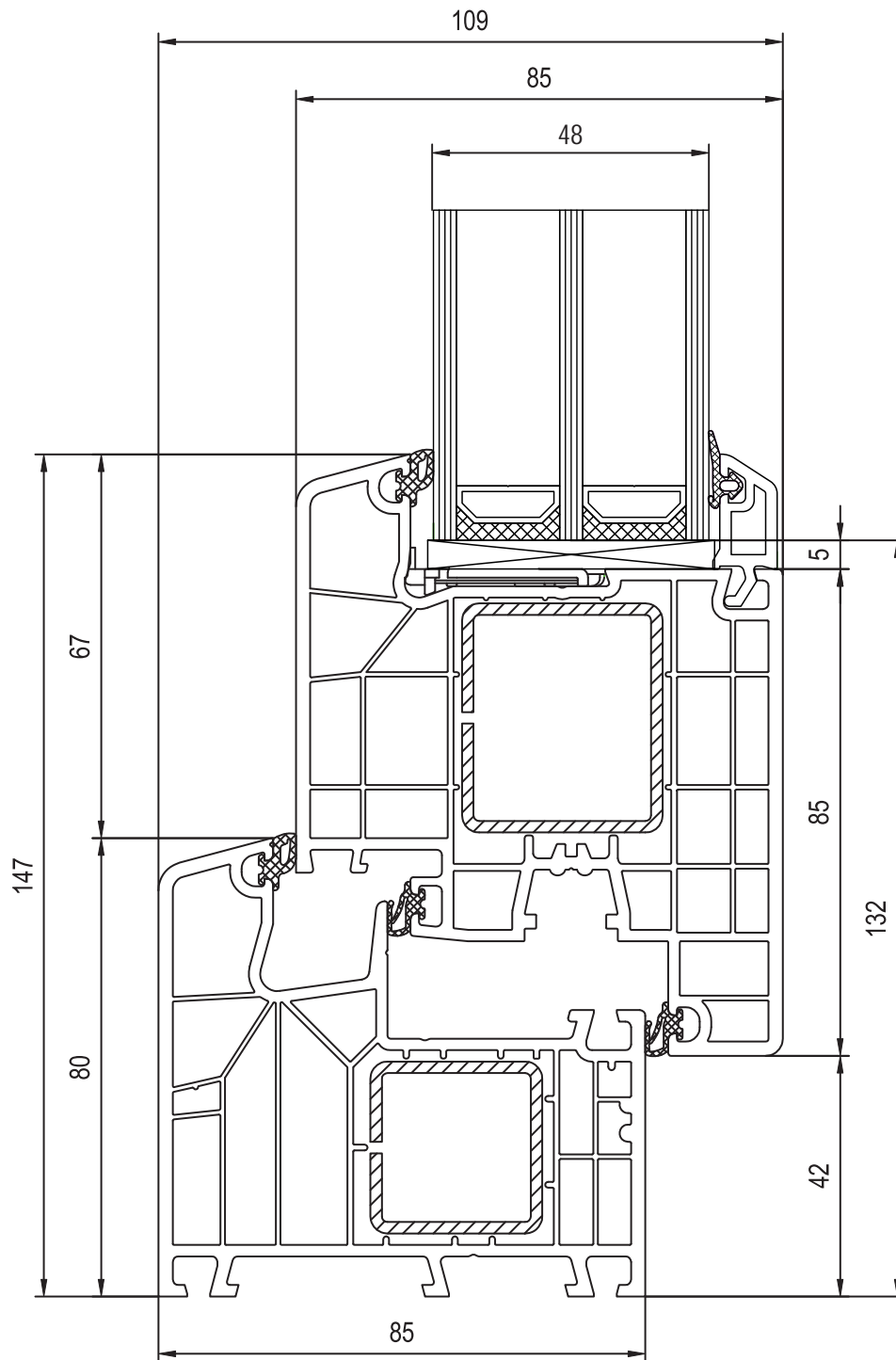
Telaio Classic-line, ante finestra Round-line





-  Drzwi wejściowe Classic-line, otwierane do wewnątrz
-  Porte d'entrée Classic-line, ouverture vers l'intérieur
-  Deur Classic-line, naar binnen opendraaiend
-  Eingangstür Classic-line, nach Innen öffnend
-  Porta d'ingresso Classic-line, l'apertura verso interno



IDEAL 8000

180x05 - 180x31

**OKO
OKNA**

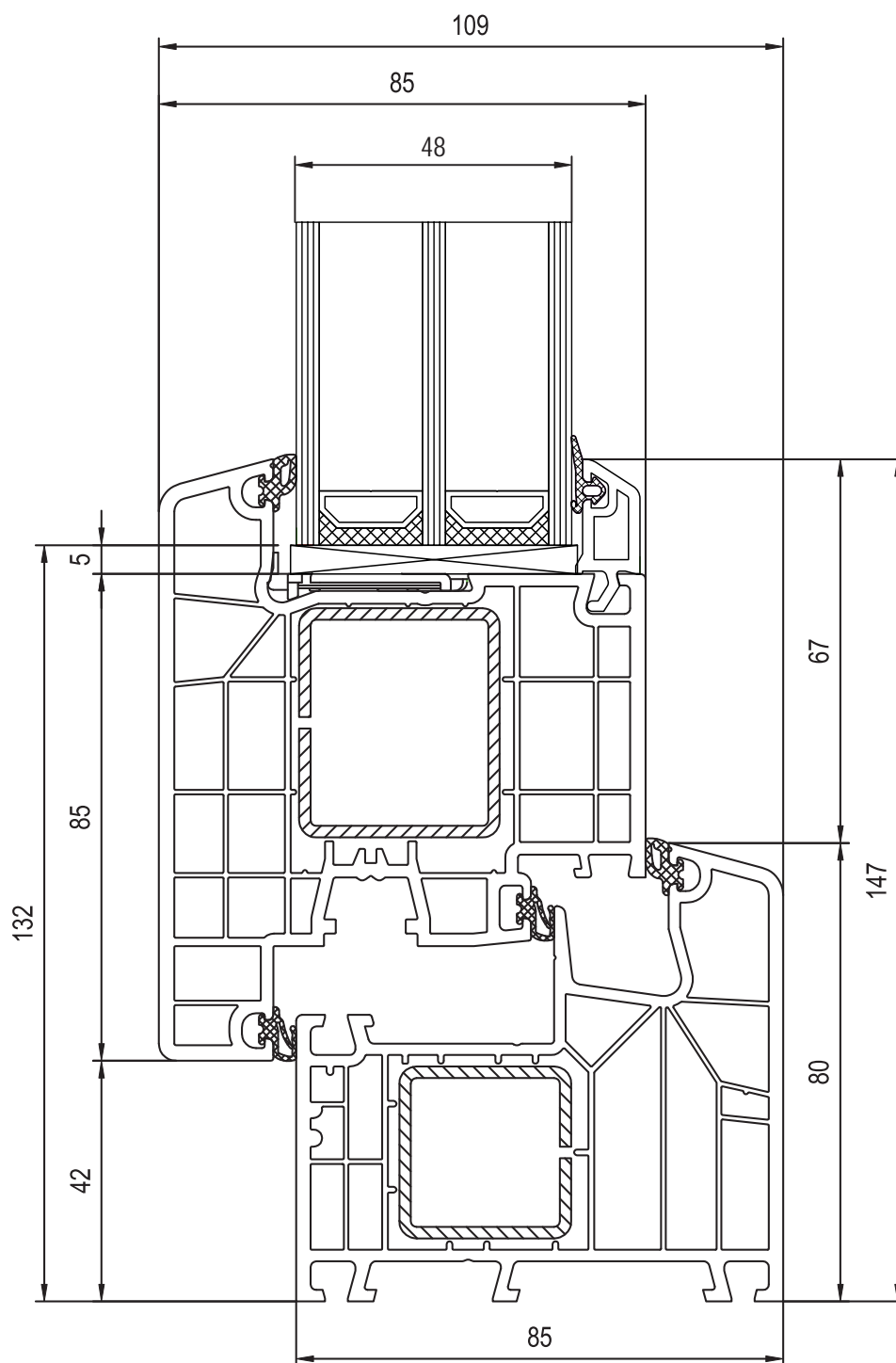

Drzwi wejściowe Classic-line, otwierane na zewnątrz

Porte d'entrée Classic-line, ouverture vers l'extérieur

Deur Classic-line, naar buiten opendraaiend

Eingangstür Classic-line, nach Aussen öffnend

Porta d'ingresso Classic-line, l'apertura verso esterno



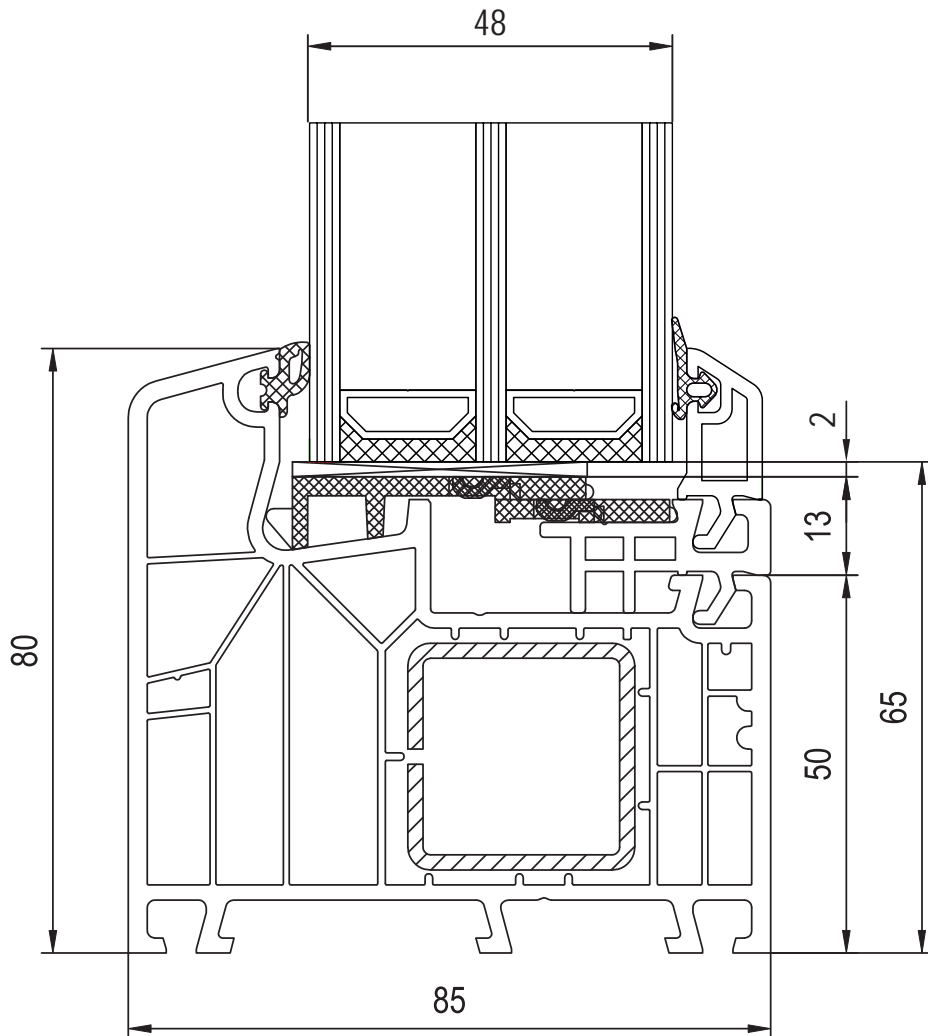

-  Szklenie stałe w ramie Classic-line
-  Dormant standard Classic-line
-  Kader standard Classic-line
-  Standardrahmen Classic-line
-  Telaio standard Classic-line



IDEAL 8000

180x03

eko
okna

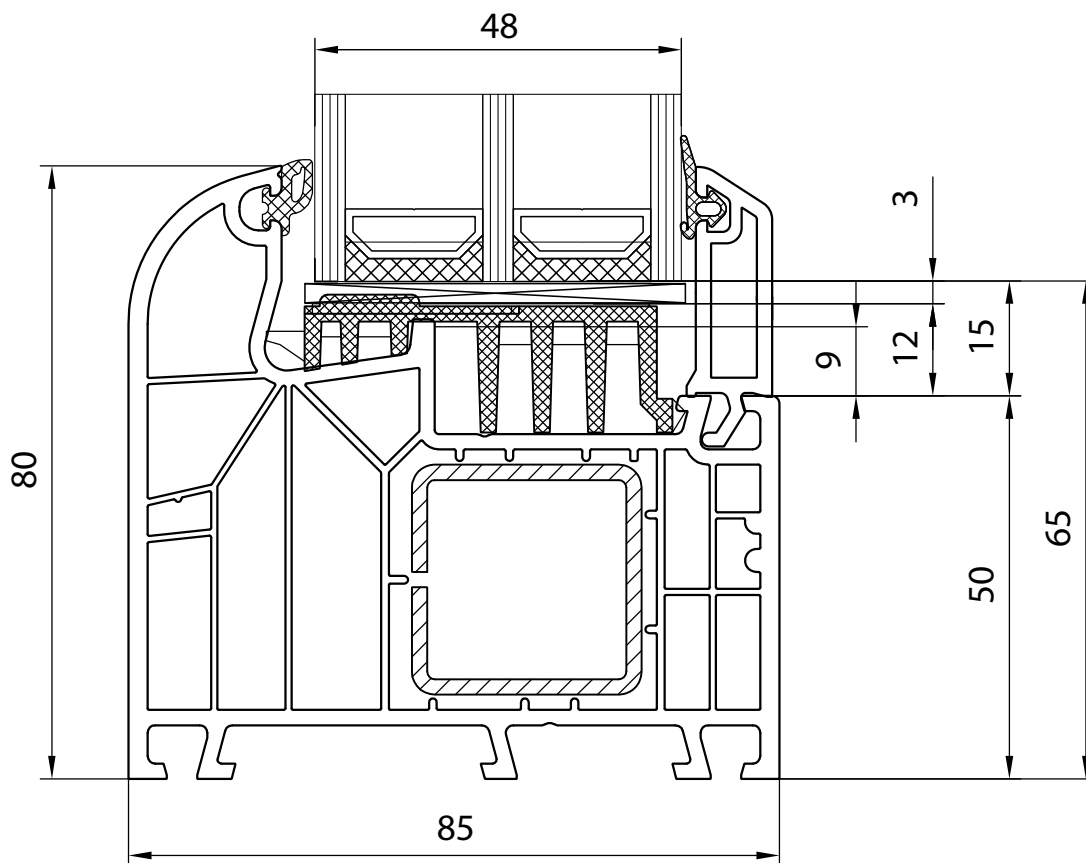

Szklenie stałe w ramie Round-line 





Dormant standard Round-line 

Kader standard Round-line 

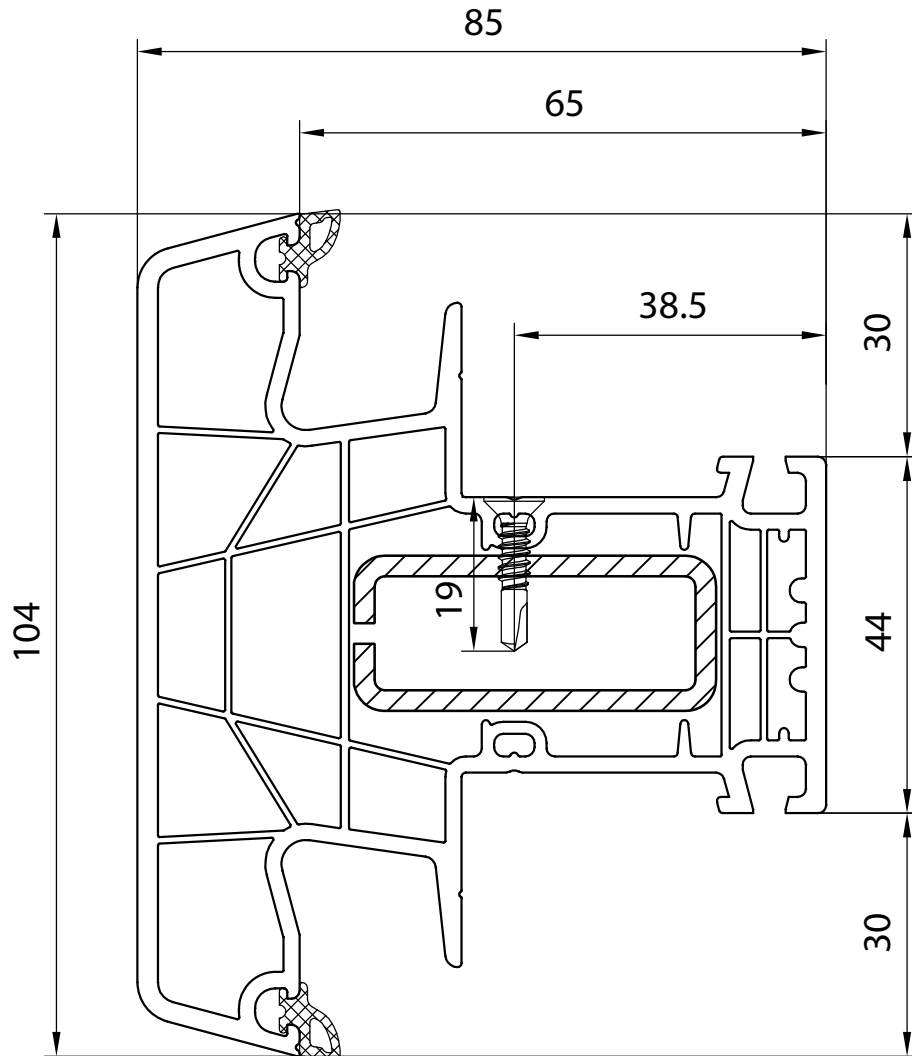
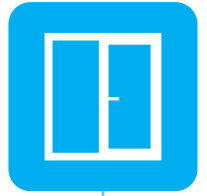
Standardrahmen Round-line 

Telaio standard Round-line 



-  Słupek stały 104 mm Classic-line (używany tylko w ramie)
-  Meneau fixe 104 mm Classic-line (utilisé uniquement pour le dormant)
-  Vaste stijl 104 mm Classic-line (wordt gebruikt alleen in het kader)
-  Querkämpfer 104 mm Classic-line (nur für Rahmen bestimmt)
-  Montante fisso 104 mm Classic-line (usato solo nel telaio)

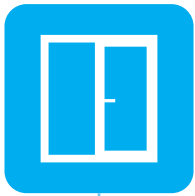

IDEAL 8000

180x43

**OKO
OKNA**

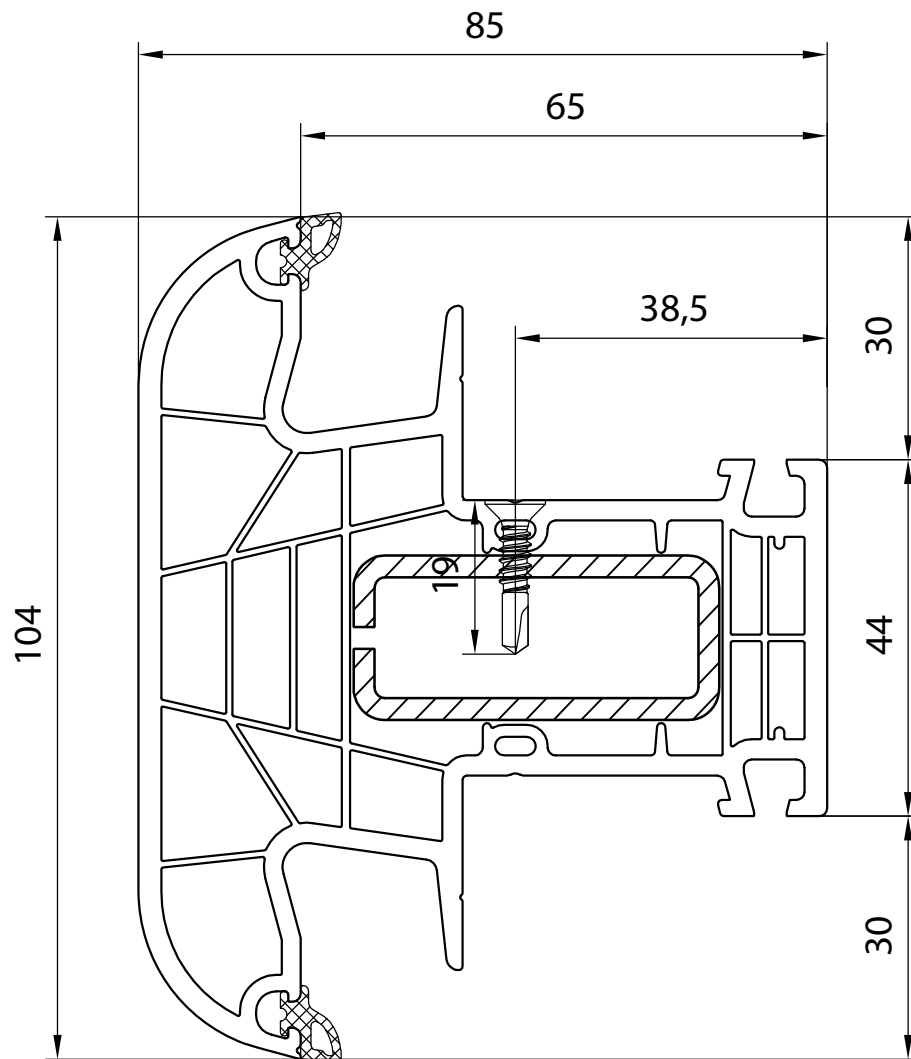

Słupek stały 104 mm Round-line



Meneau fixe 104 mm Round-line



Vaste stijl 104 mm Round-line









Querkämpfer 104 mm Round-line

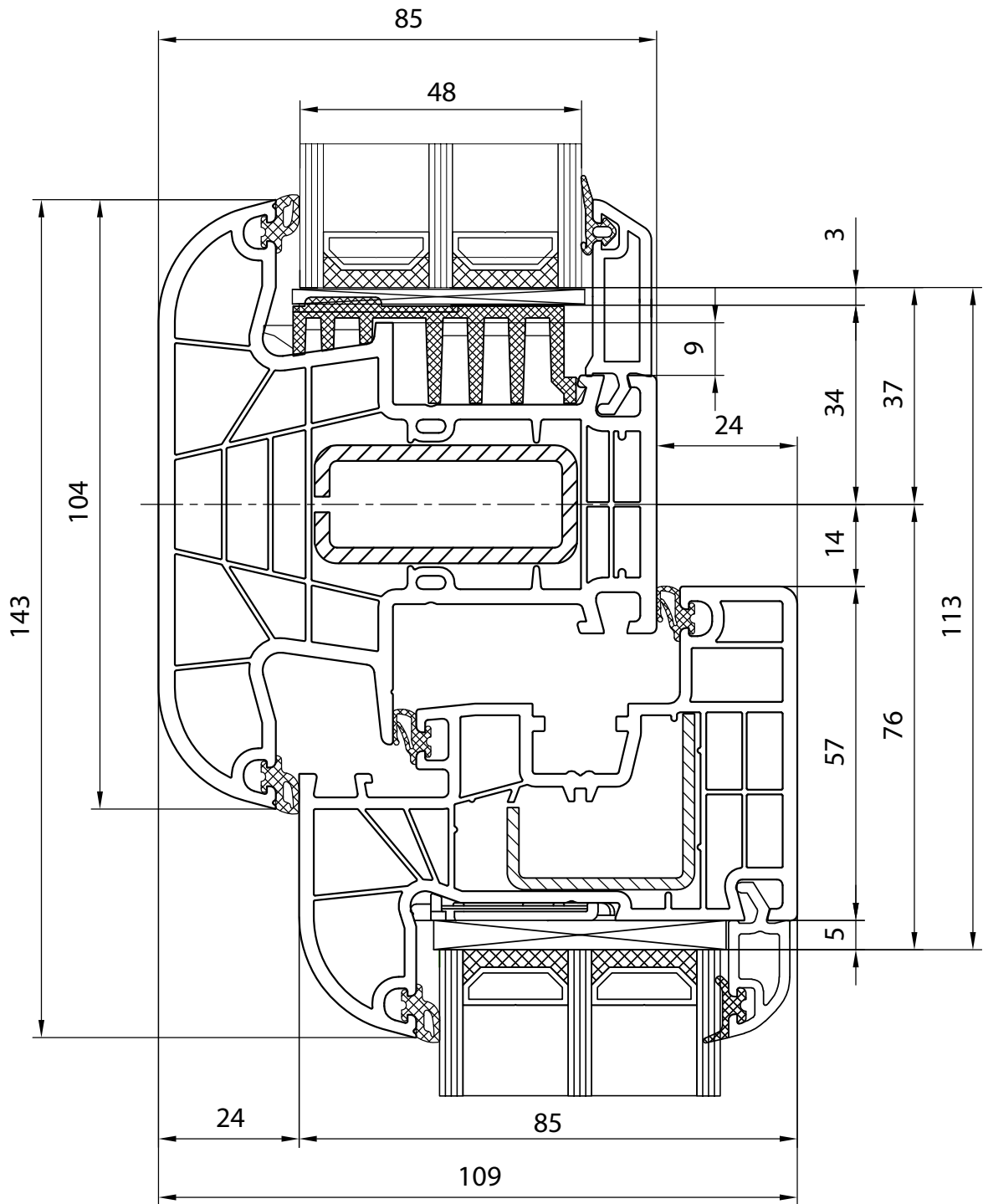

Montante fisso 104 mm Round-line





-  Słupek stały ze szkleniem i skrzydłem okiennym Round-line
-  Cadre et ouvrant de fenêtre Round-line avec meneau fixe
-  Tussenstijl met beglazing in kader en vleugel Round-line
-  Fester Pfosten mit Festverglasung und Flügel Round-line
-  Montante fisso con vetraggio nel telaio e con anta Round-line

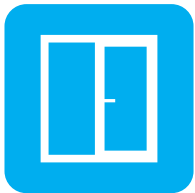

IDEAL 8000

180x22 - 180x43 - 180x22

**OKO
OKNA**

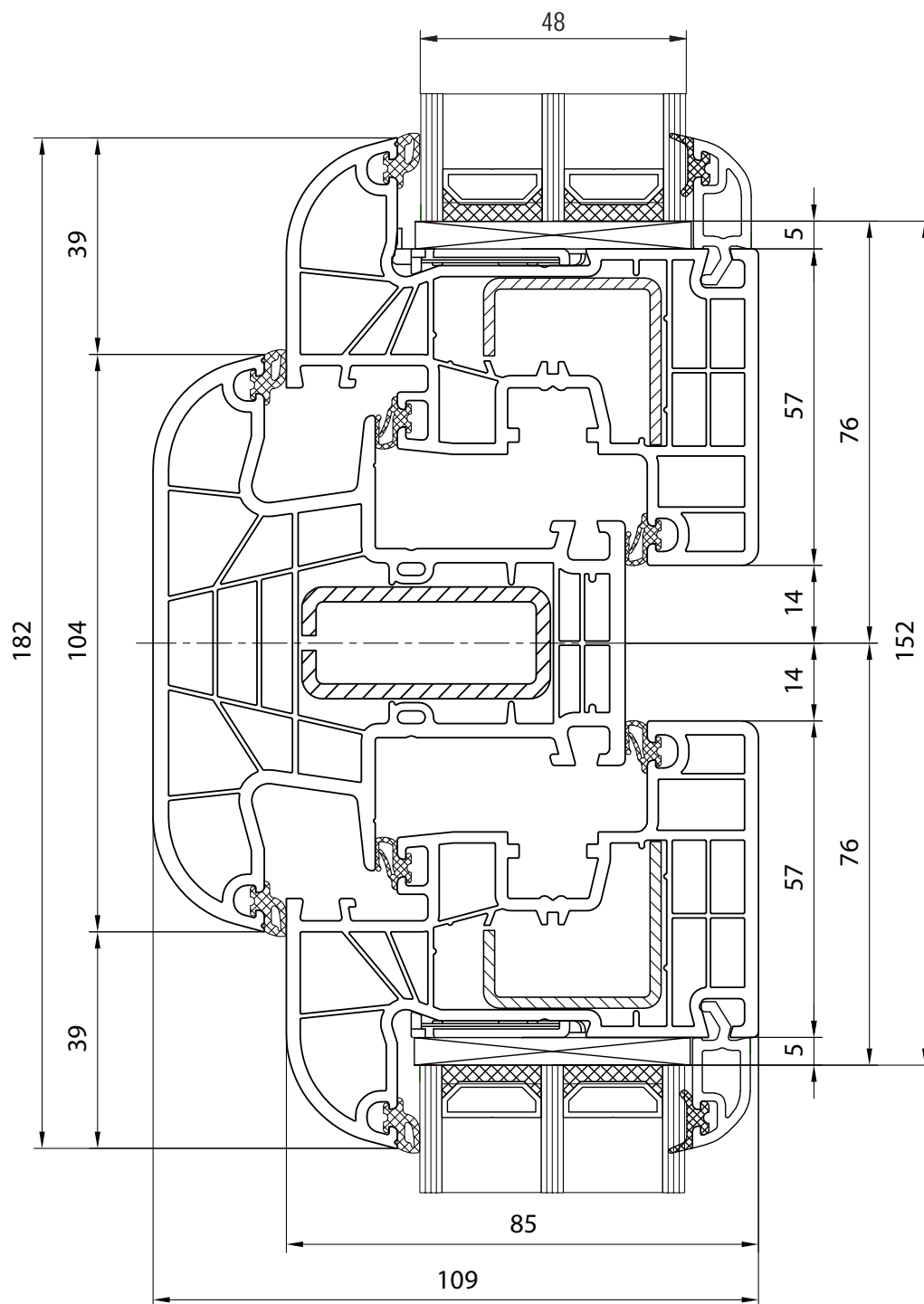

Przekrój przez słupek stały 104 mm z dwoma skrzydłami Round-line

Coupe de meneau fixe 104 mm avec ouvrant Round-line





Aansluiting van vleugels Round-line met vaste stijl 104 mm

Fester Pfosten 104 mm mit Flügel Round-line

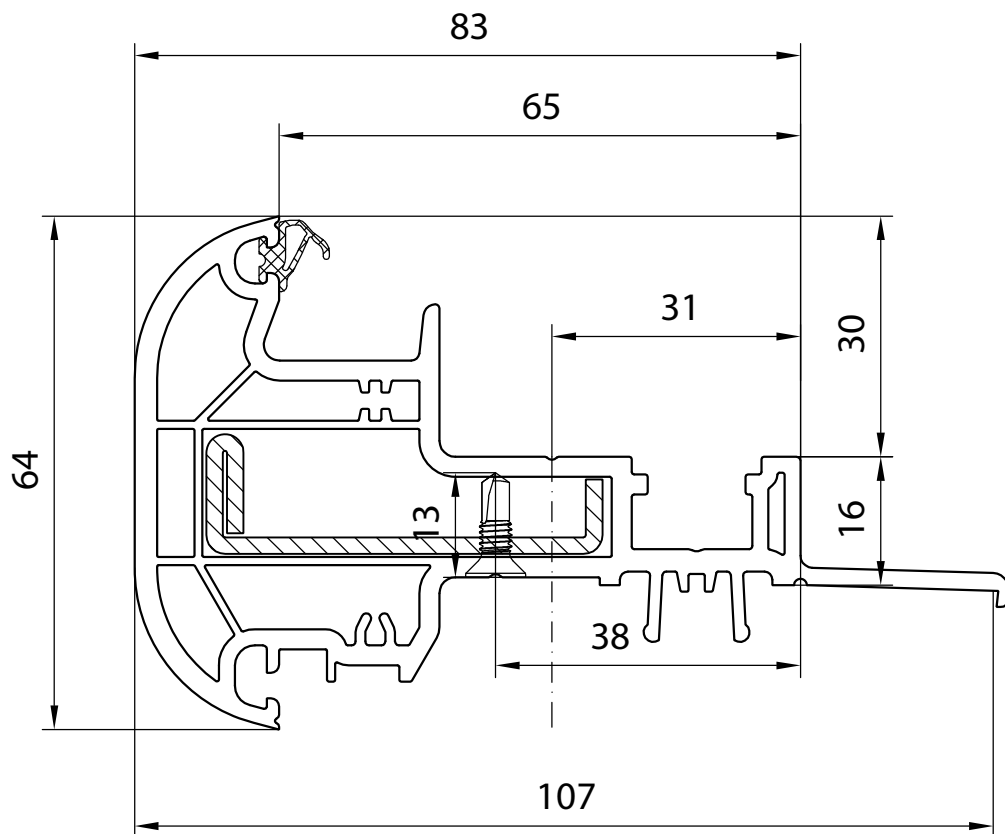
Guinzione del montante fisso 104 mm con due ante Round-line





-  Słupek ruchomy 64 mm Round-line (wąski)
-  Meneau mobile 64 mm Round-line
-  Mobile paal (stulp) 64 mm Round-line
-  Stulp 64 mm Round-line
-  Montante mobile 64 mm Round-line

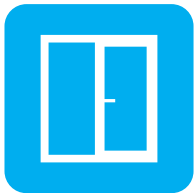

IDEAL 8000

180x22 - 180x65 - 180x22

**ЕКО
ОКНА**

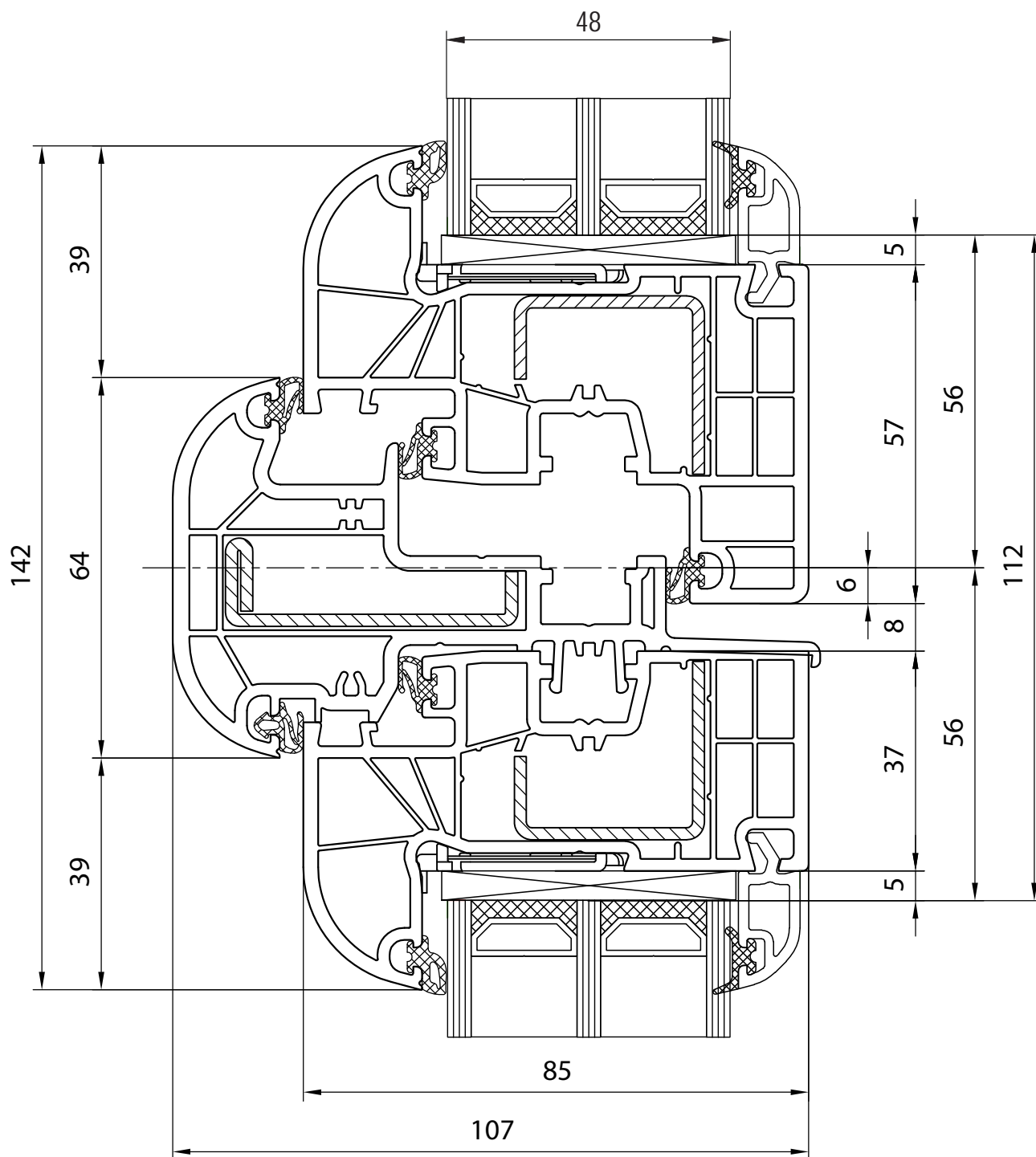

Przekrój przez ruchomy stupek 64 mm z dwoma skrzydłami okiennymi Round-line

Coupe de deux ouvrants de fenetre Round-line, meneau mobile 64 mm





Aansluiting van twee raam vleugels Round-line met stulp 64 mm

Zwei Fensterflügel Round-line, verbunden mit Hilfe eines Stulps 64 mm

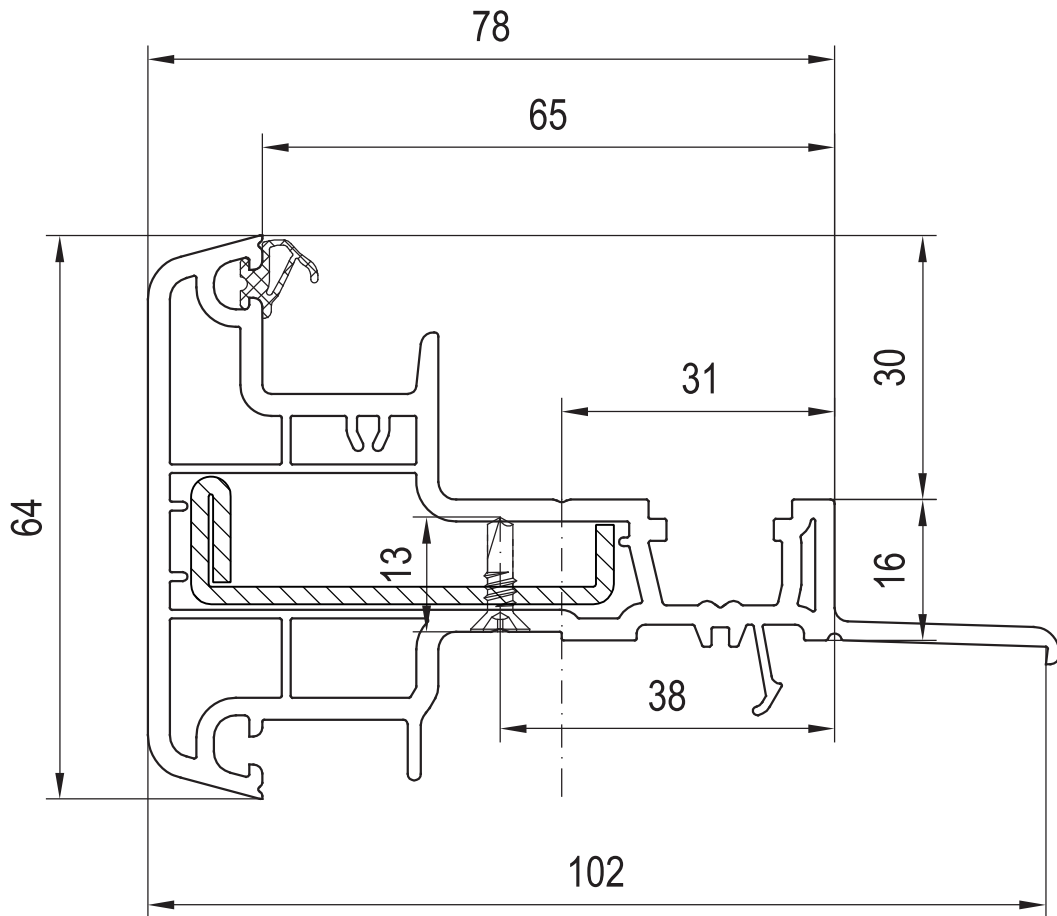
Giunzione di due ante finestra Round-line con montante mobile 64 mm





-  Słupek ruchomy 64 mm Classic-line (wąski)
-  Meneau mobile 64 mm Classic-line
-  Mobile paal (stulp) 64 mm Classic-line
-  Stulp 64 mm Classic-line
-  Montante mobile 64 mm Classic-line

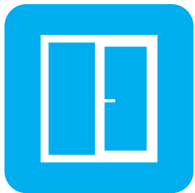

IDEAL 8000

180x20 - 180x64 - 180x20

**ЕКО
ОКНА**

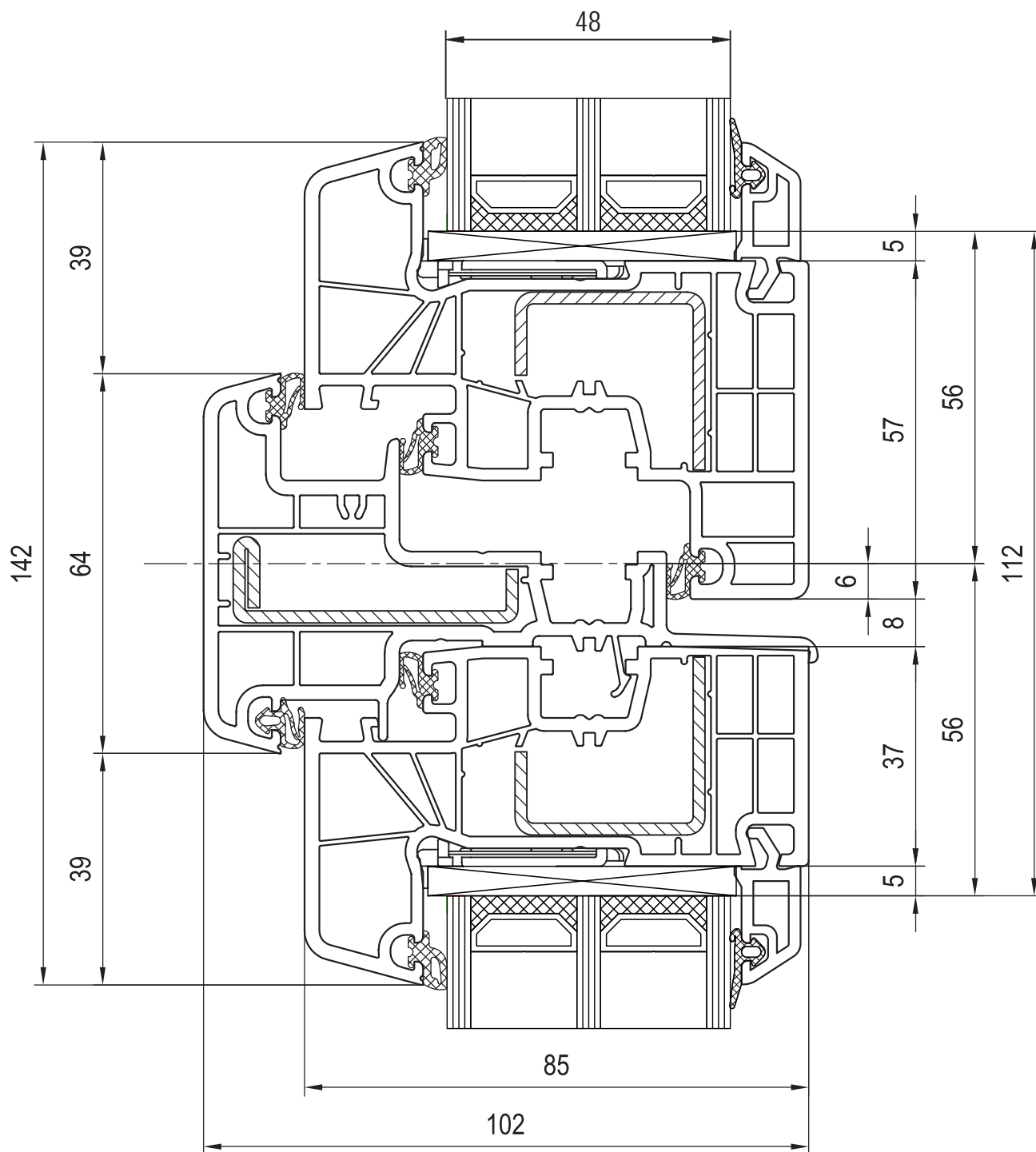

Przekrój przez ruchomy stulpek 64 mm z dwoma skrzydłami okiennymi Classic-line

Coupe de deux ouvrants de fenêtre Classic-line, meneau mobile 64 mm

Aansluiting van twee raam vleugels Classic-line met stulp 64 mm

Zwei Fensterflügel Classic-line, verbunden mit Hilfe eines Stulps 64 mm

Giunzione di due ante finestra Classic-line con montante mobile 64 mm



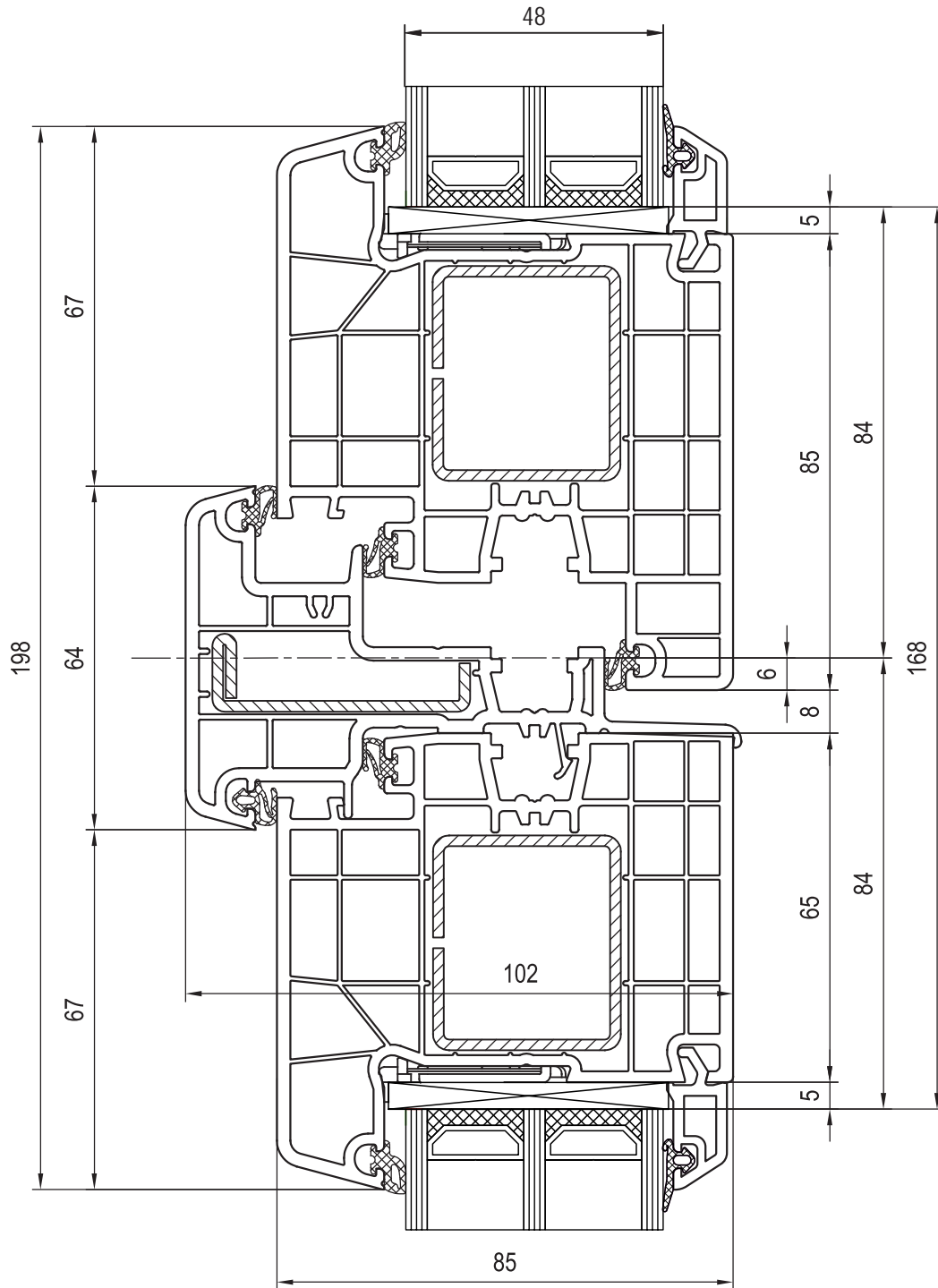

Przekrój przez profil drzwiowy Classic-line ze słupkiem ruchomym 64 mm, otwierane do wewnątrz



Coupe de deux ouvrants de porte Classic-line, meneau mobile, 64 mm ouverture vers l'intérieur



Aansluiting van twee deur vleugels Classic-line naar binnen opendraaiend met stulp 64 mm



Zwei Türflügel Classic-line nach Innen öffnend, Stulp 64 mm



Giunzione di due ante della porta Classic-line con montane mobile 64 mm, l'apertura verso interno



IDEAL 8000

180x31 - 180x64 - 180x31

**OKO
OKNA**

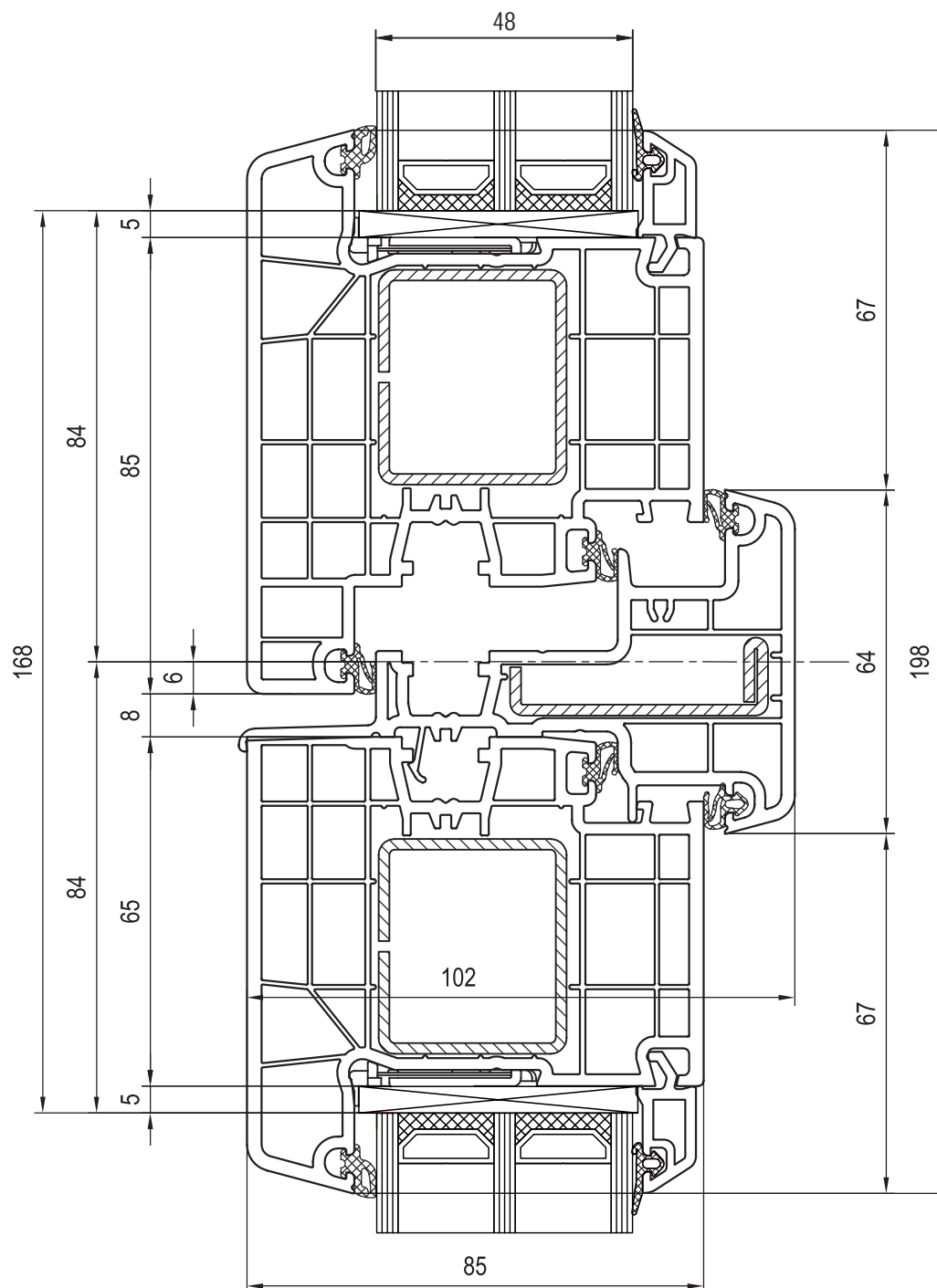

Przekrój przez profil drzwiowy Classic-line ze słupkiem ruchomym 64 mm, otwierane na zewnątrz

Coupe de deux ouvrants de porte Classic-line, meneau mobile 64 mm, ouverture vers l'extérieur





Aansluiting van twee deur vleugels Classic-line naar buiten opendraaiend met stulp 64 mm

Zwei Türflügel Classic-line verbunden mit Hilfe eines Stulps 64 mm, nach Aussen öffnend

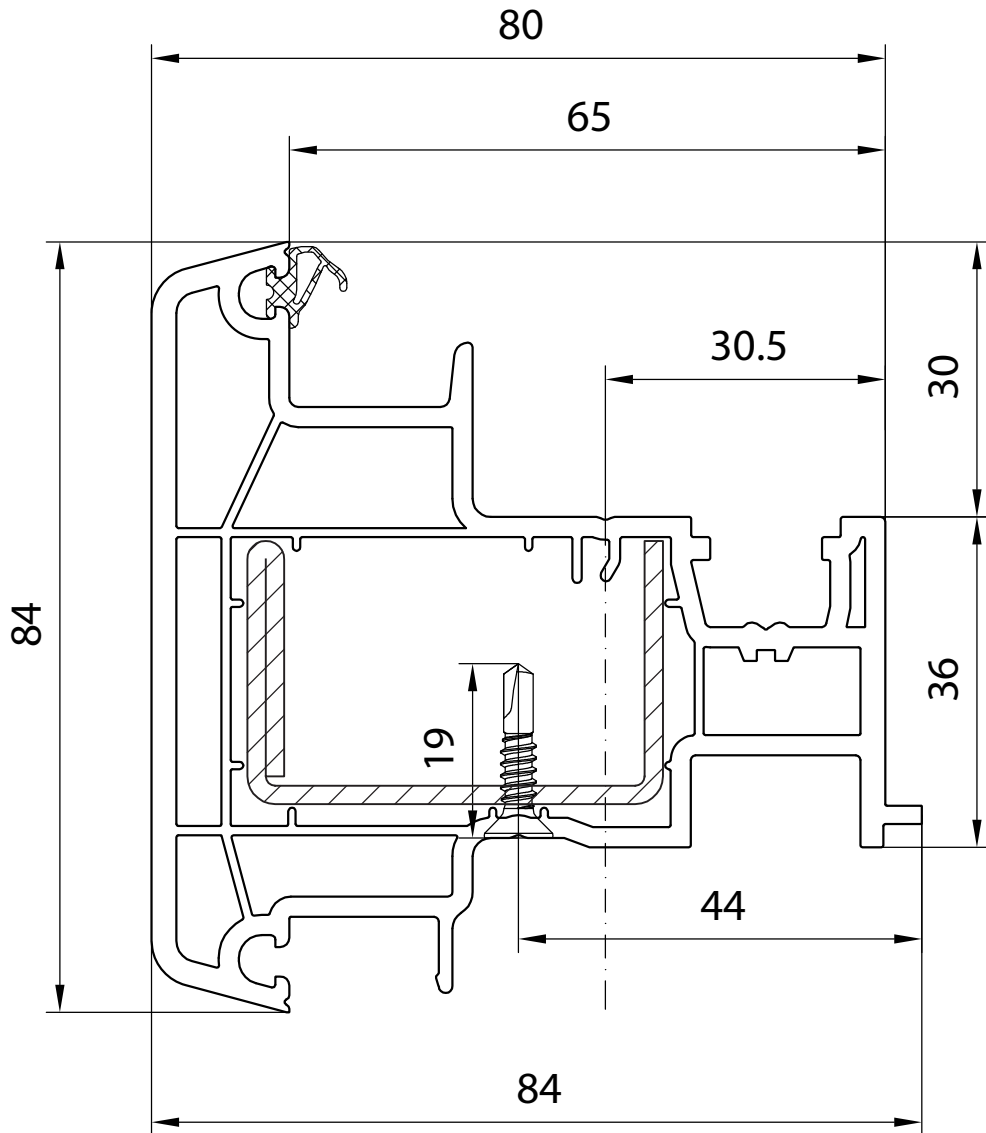
Giunzione di due ante della porta Classic-line con montane mobile 64 mm, l'apertura verso esterno





-  Słupek ruchomy 84 mm (szeroki)
-  Meneau mobile 84 mm
-  Brede stulp 84 mm
-  Breiter Stulp 84 mm
-  Montante mobile 84 mm

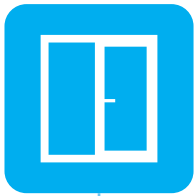

IDEAL 8000

180x20 - 180x66 - 180x20

**OKO
OKNA**

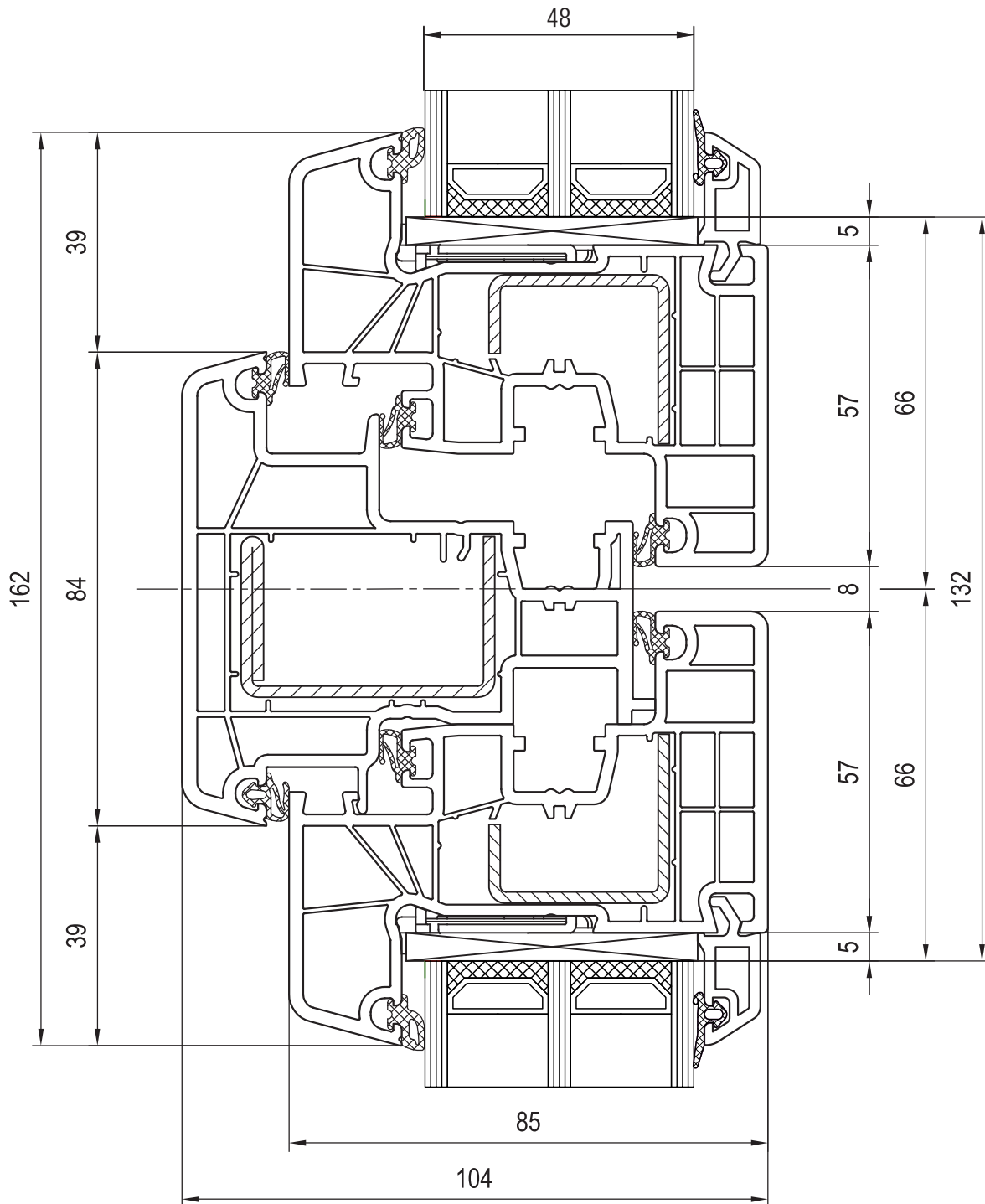

Przekrój przez słupek ruchomy 84 mm z dwoma skrzydłami okiennymi Classic-line

Coupe de deux ouvrants de fenêtre Classic-line, meneau mobile 84 mm

Aansluiting van twee raam vleugels Classic-line met brede stulp 84 mm

Zwei Fensterflügel Classic-line, verbunden mit Hilfe eines Stulps 84 mm

Giunzione di due ante finestra Classic-line con montante mobile 84 mm



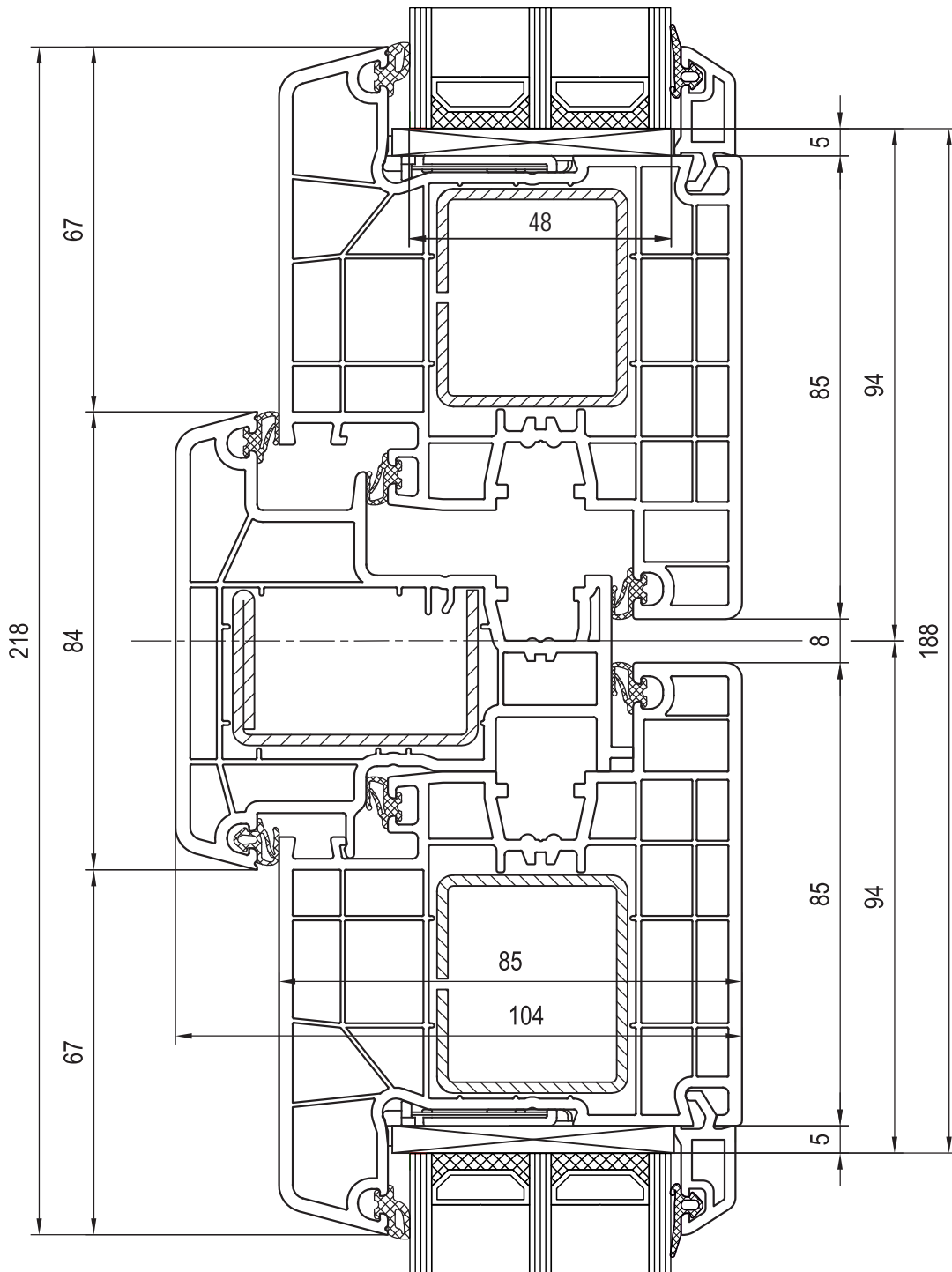

Przekrój przez słupek ruchomy 84 mm z dwoma skrzydłami drzwiowymi, otwierane do wewnątrz



Coupe de deux ouvrants de porte, meneau mobile 84 mm, ouverture vers l'intérieur



Aansluiting van twee deur vleugels naar binnen opendraaiend met brede stulp 84 mm



Zwei Türflügel, verbunden mit Hilfe eines breiten Stulps 84 mm nach Innen öffnend



Giunzione di due ante della porta con montane largo mobile 84 mm, l'apertura verso interno



IDEAL 8000

180x31 - 180x66 - 180x31

**OKO
OKNA**

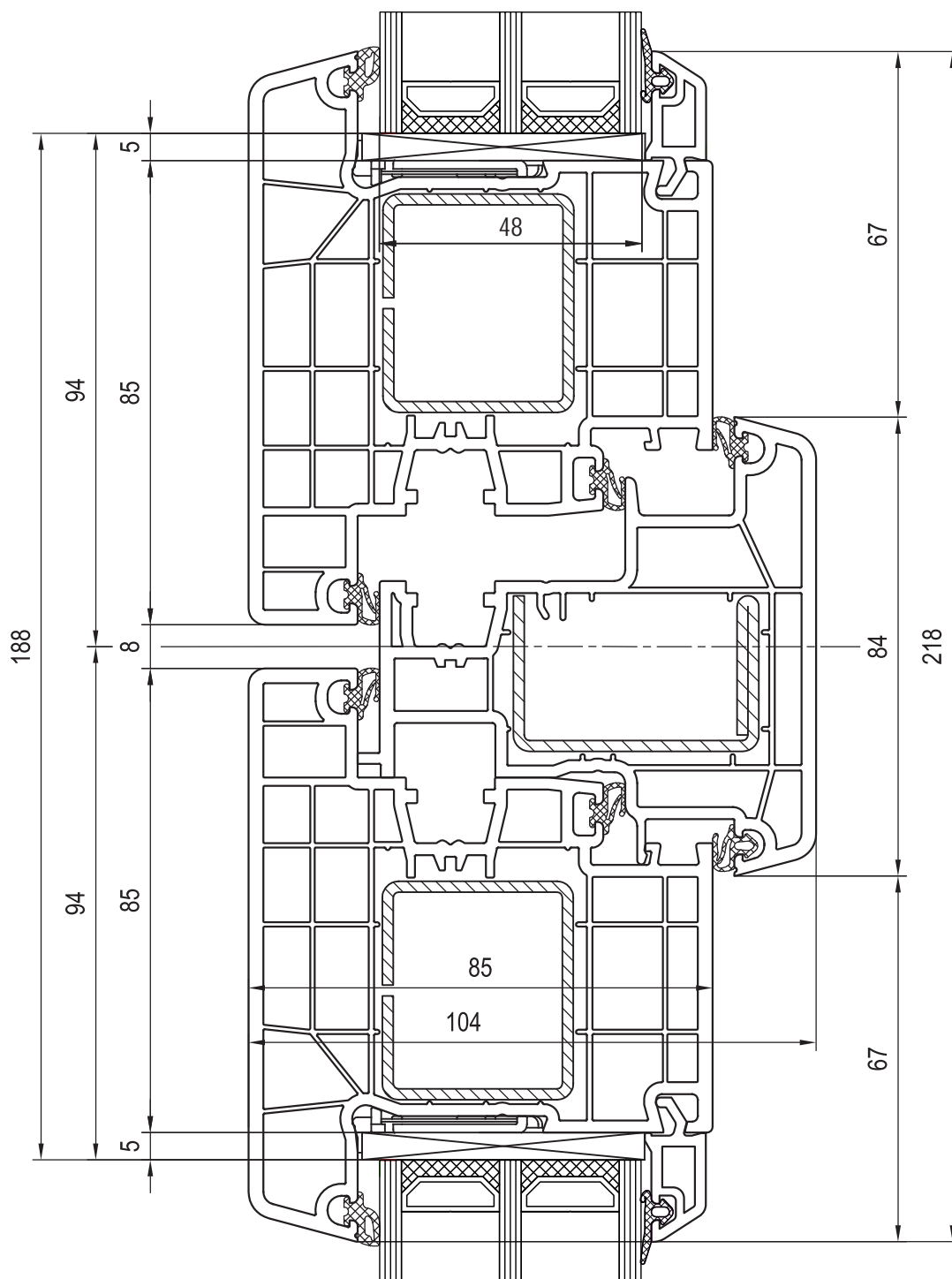

Przekrój przez słupek ruchomy 84 mm z dwoma skrzydłami drzwiowymi, otwierane na zewnątrz

Coupe de deux ouvrants de porte, meneau mobile 84 mm, ouverture vers l'extérieur

Aansluiting van twee deur vleugels naar buiten opendraaiend met brede stulp 84 mm

Zwei Türflügel, verbunden mit Hilfe eines breiten Stulps 84 mm nach Aussen öffnend

Giunzione di due ante della porta con montante largo mobile 84 mm, l'apertura verso interno



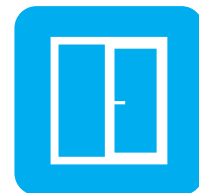

BLOCKPROFIL NL

Stal pokazana na rysunku może nie być stalą stosowaną standardowo.



BLOCKPROFIL NL

Renfort en acier présenté sur le dessin ci-dessus est en option.



BLOKPROFIEL NL

Staal die u op de tekening ziet, is niet standaard.



BLOCKPROFIL NL

Der angewendete Stahlkern kann von dem abgebildeten Kern abweichen.



BLOCKPROFIL NL

L'acciaio presentato sul disegno può essere un acciaio non standard.



BLOCKPROFIL NL

140x53

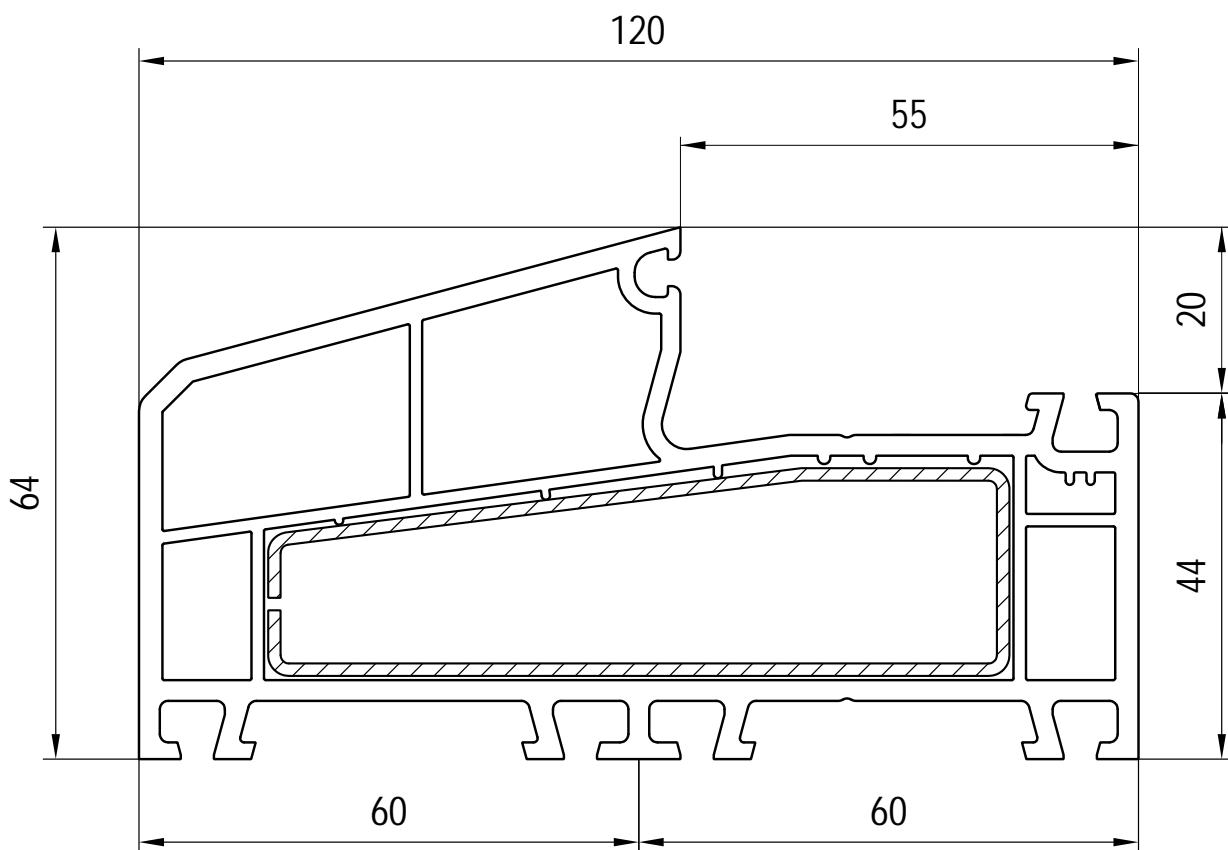

BLOCKPROFIL NL - Rama typu NL (bez noska)



BLOCKPROFIL NL - Dormant type NL (sans le nez)



BLOKPROFIEL NL - Kader type NL (zonder aanslag / neusje)



BLOCKPROFIL NL - Rahmen NL (ohne nase)



BLOCKPROFIL NL - Telaio tipo NL (senza naso)



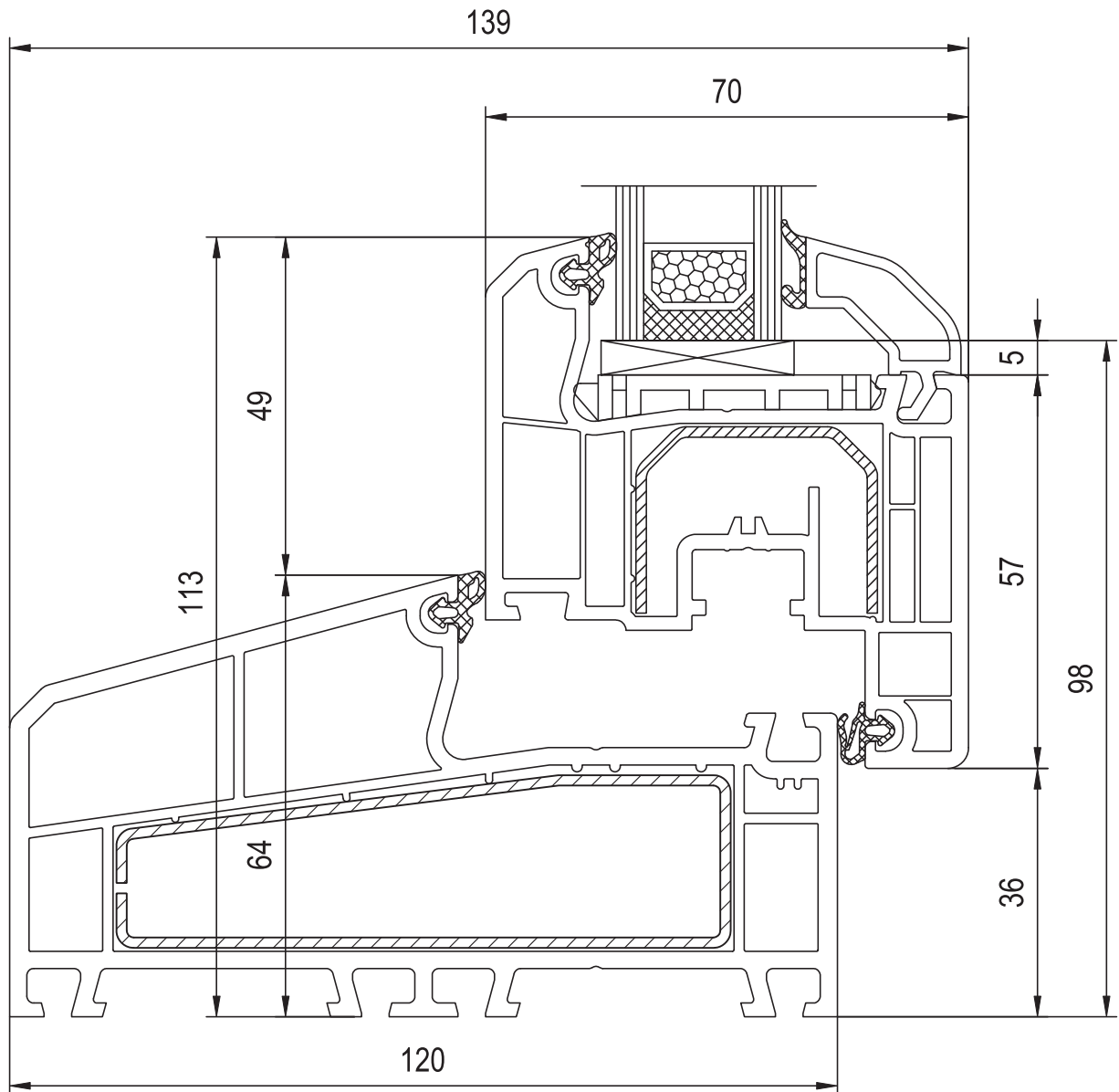

BLOCKPROFIL NL - Rama NL (bez noska) ze skrzydłem okiennym Soft-line



BLOCKPROFIL NL - Coupe de dormant ouvrant de fenêtre Soft-line (sans le nez)



BLOKPROFIEL NL - Aansluiting van raam kader en vleugels Soft-line (zonder aanslag / neusje)



BLOCKPROFIL NL - Rahmen mit Fenstreflügel Soft-line (ohne nase)



BLOCKPROFIL NL - Giunzione del telaio con anta finestra Soft-line (senza naso)



BLOCKPROFIL NL

140x53 - 140x30

**OKO
OKNA**

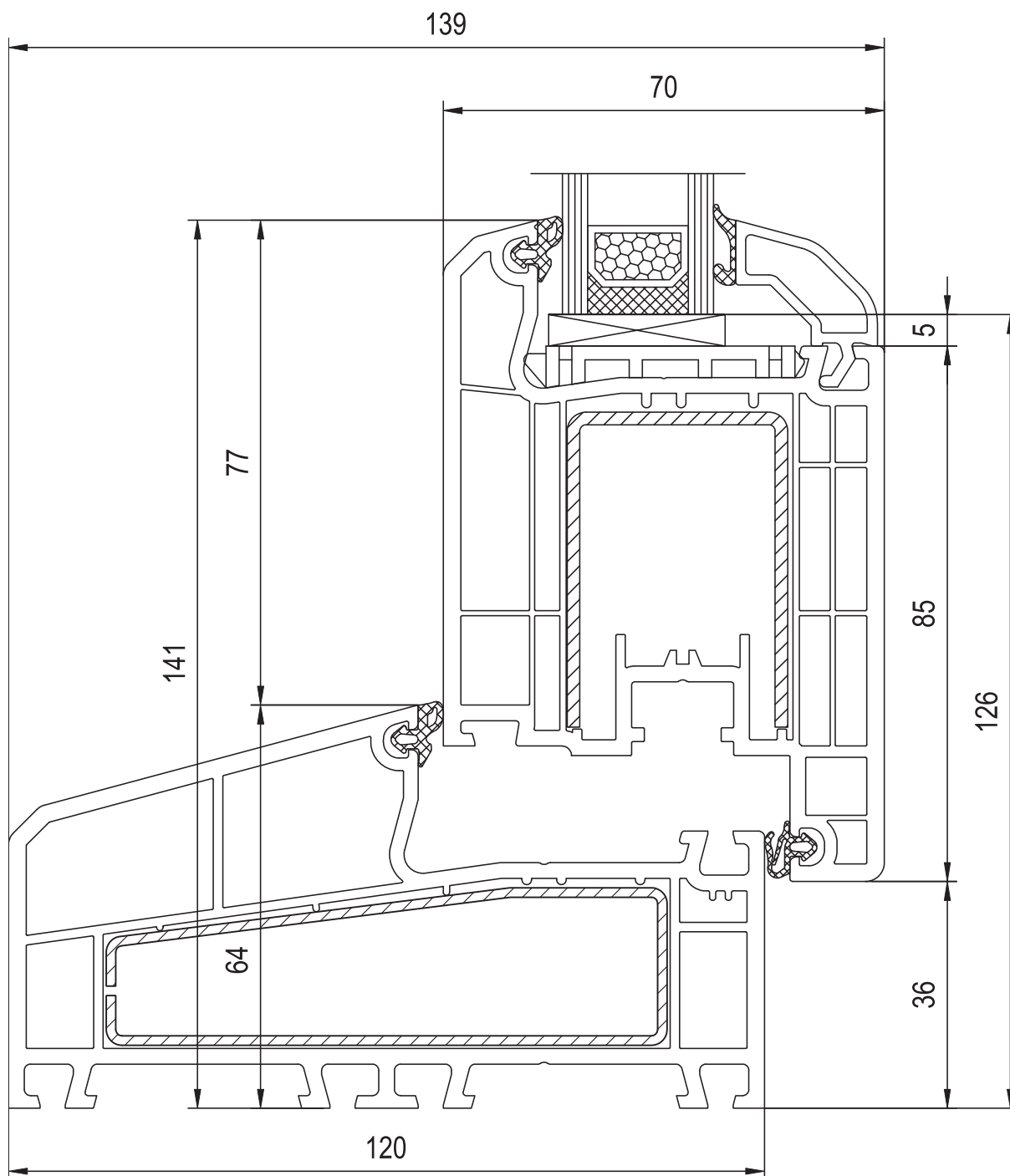

BLOCKPROFIL NL - Rama NL (bez noska) ze skrzydłem tarasowym, otwierane do wewnątrz

BLOCKPROFIL NL - Coupe de dormant avec ouvrant de passage (sans le nez)

BLOKPROFIEL NL - Aansluiting van terras kader met vleugel (zonder aanslag / neusje)

BLOCKPROFIL NL - Rahmen mit Terrassenflügel (ohne nase), nach Innen öffnend

BLOCKPROFIL NL - Giunzione del telaio con anta di portaveranda (senza naso)

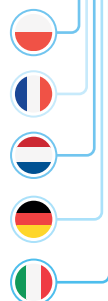

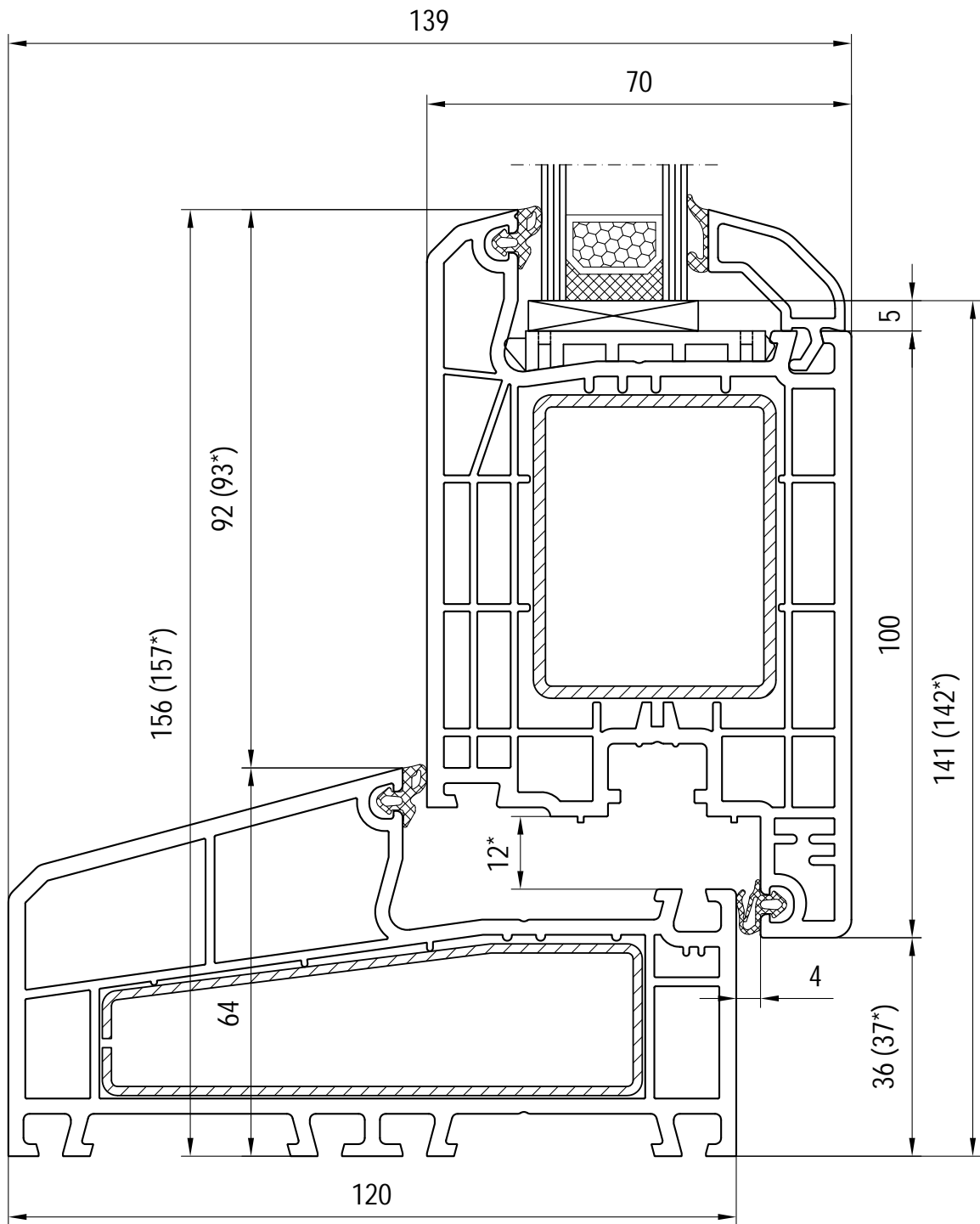

BLOCKPROFIL NL - Rama NL (bez noska) ze skrzydłem drzwiowym, otwierane do wewnątrz



BLOCKPROFIL NL - Ouvrant de porte, ouverture vers l'intérieur (sans le nez)



BLOKPROFIEL NL - Deur vleugel, naar binnen opendraaiend (zonder aanslag / neusje)



BLOCKPROFIL NL - Türflügel, nach Innen öffnend (ohne nase)



BLOCKPROFIL NL - Anta della porta, l'apertura verso interno (senza naso)

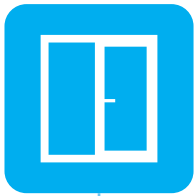

BLOCKPROFIL NL

140x54

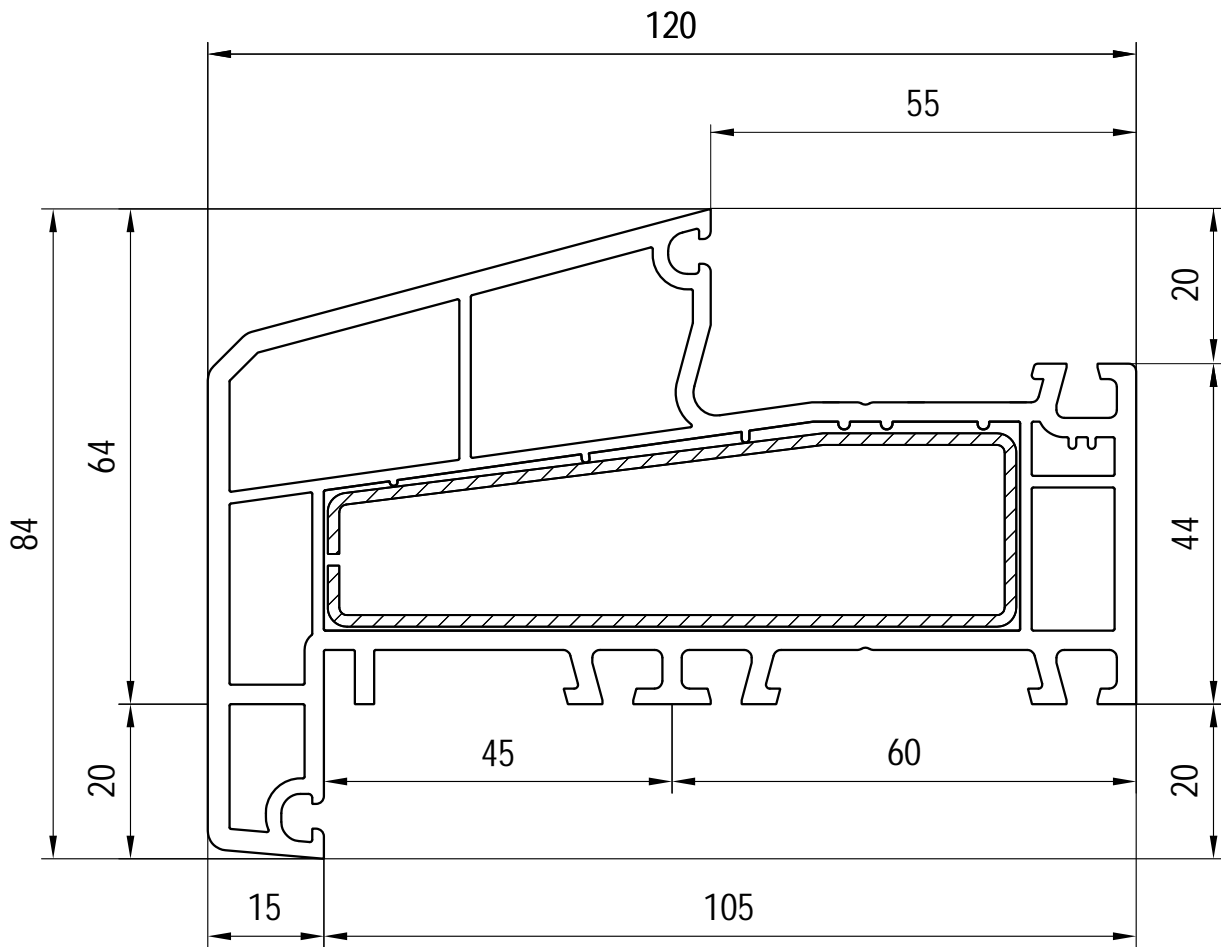

BLOCKPROFIL NL - Rama NL (z noskiem)



BLOCKPROFIL NL - Dormant type NL (avec le nez)



BLOKPROFIEL NL - Kader type NL (met aanslag / neusje)









BLOCKPROFIL NL - Rahmen NL (mit nase)

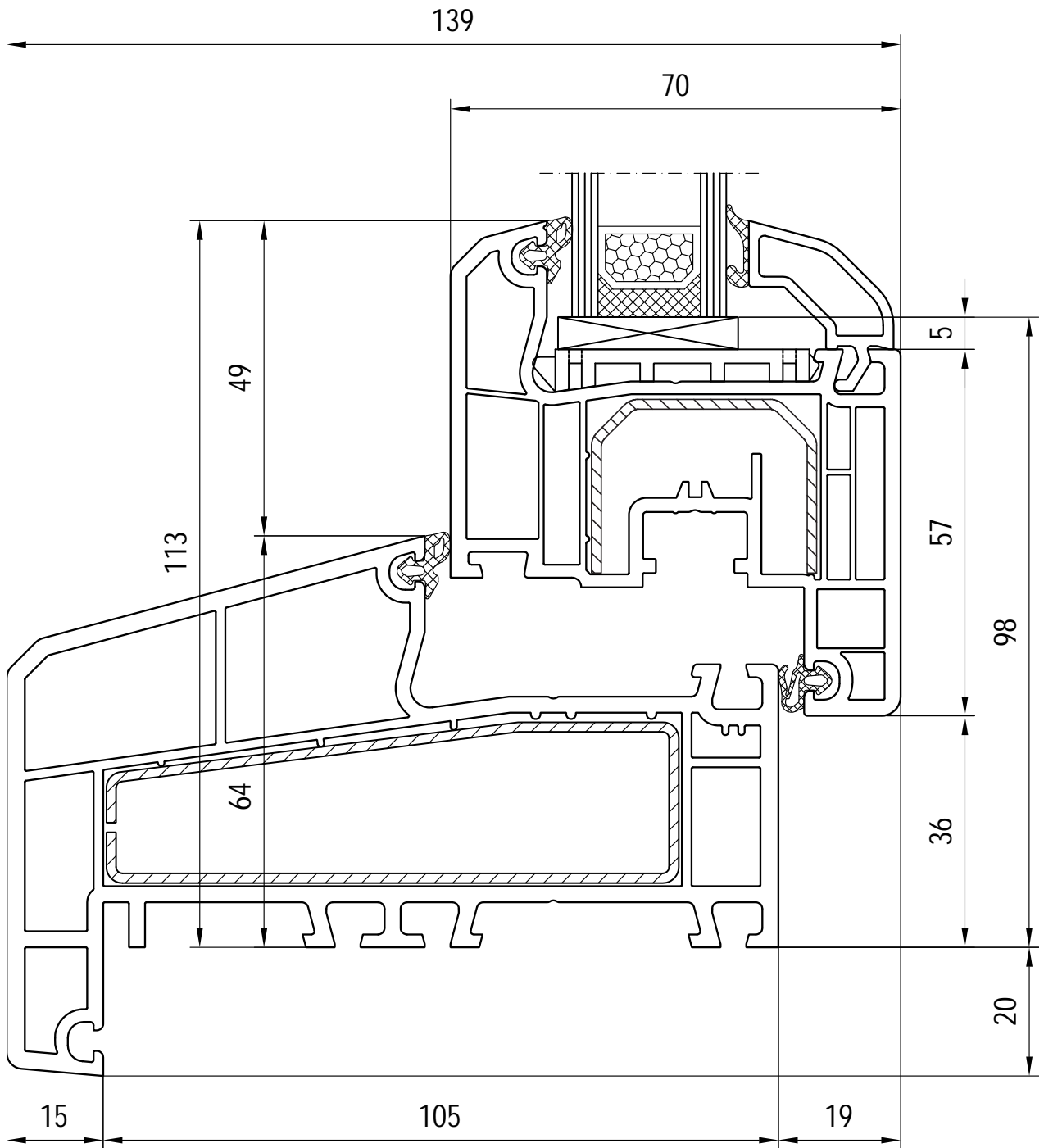

BLOCKPROFIL NL - Telaio tipo NL (con naso)





-  BLOCKPROFIL NL - Rama NL (z noskiem) ze skrzydłem okiennym Soft-line
-  BLOCKPROFIL NL - Dormant type NL (avec le nez) + ouvrant Soft-line
-  BLOKPROFIEL NL - Kader type NL (met aanslag / neusje) + Soft-line vleugel
-  BLOCKPROFIL NL - Rahmen NL (mit nase) + Flügel Soft-line
-  BLOCKPROFIL NL - Telaio tipo NL (con naso) + anta Soft-line



BLOCKPROFIL NL

140x54 - 140x30

**OKO
OKNA**

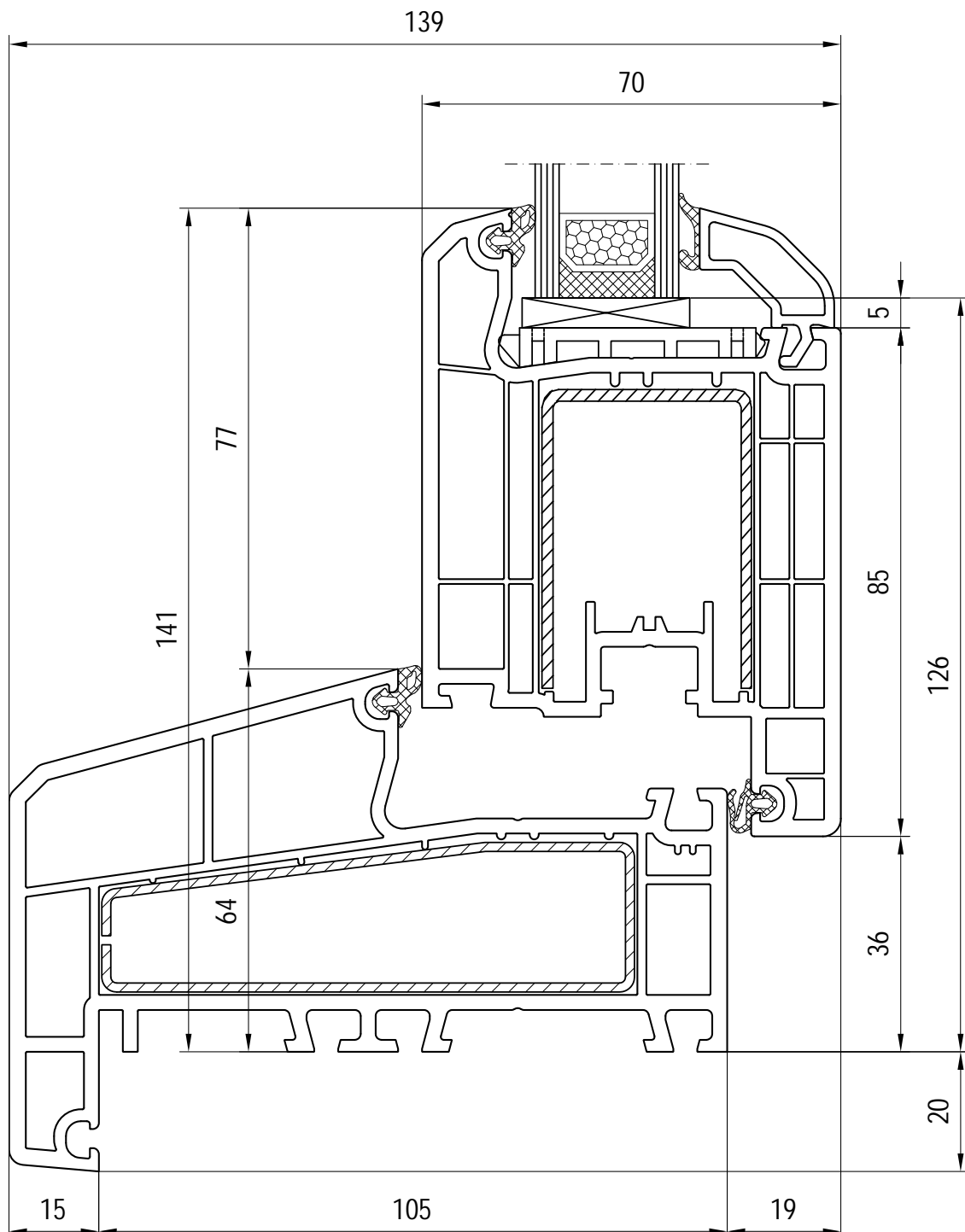

BLOCKPROFIL NL - Rama NL (z noskiem) ze skrzydłem tarasowym, otwierane do wewnątrz

BLOCKPROFIL NL - Ouvrant de passage avec le nez, ouverture vers l'intérieur

BLOKPROFIEL NL - Terras vleugel met aanslag / neusje, naar binnen opendraaiend

BLOCKPROFIL NL - Terrassenflügel mit nase, nach Innen öffnend

BLOCKPROFIL NL - Anta della portaveranda con naso, l'apertura verso interno



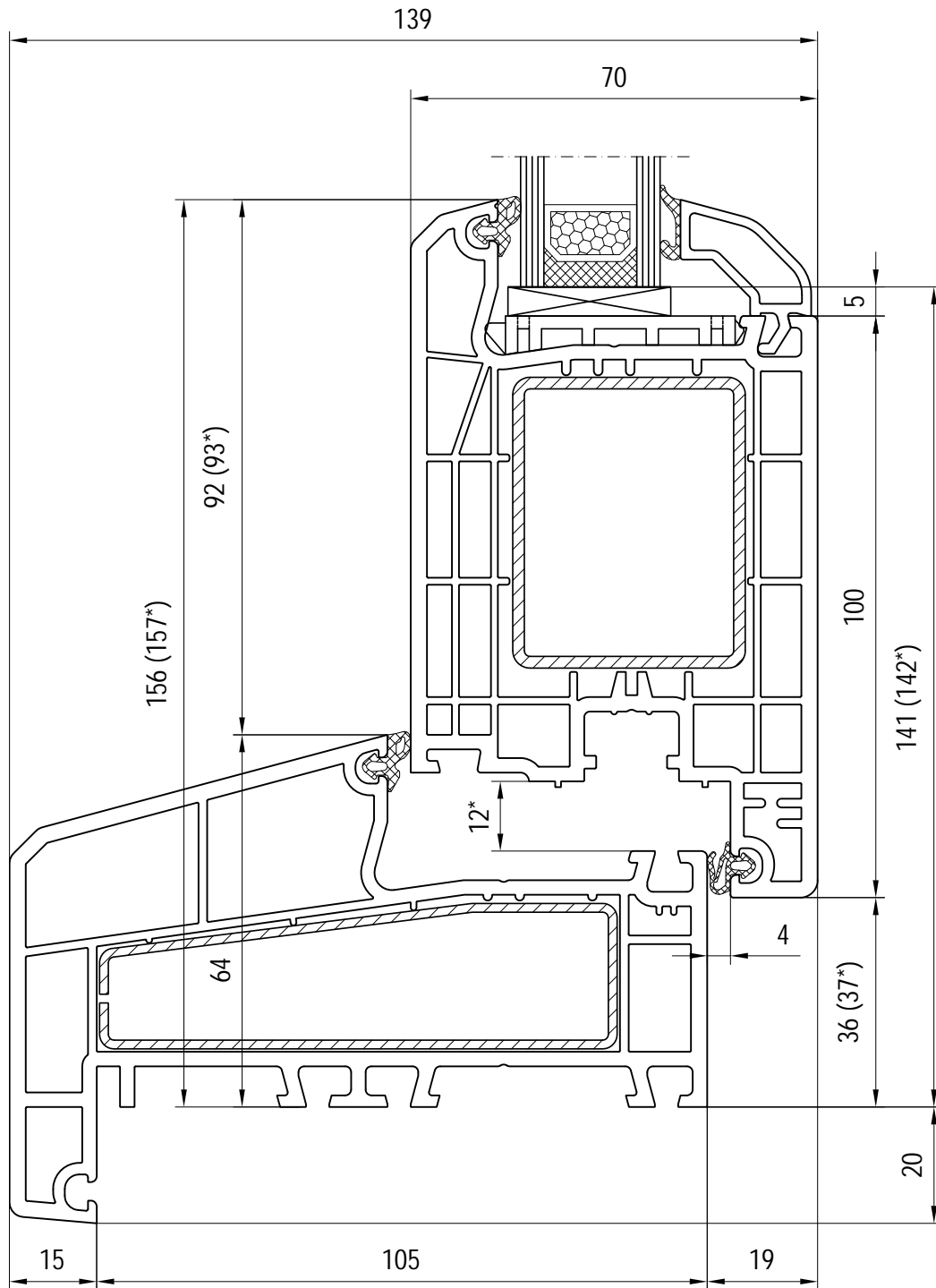
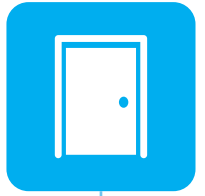

BLOCKPROFIL NL - Rama NL (z noskiem) ze skrzydłem drzwiowym



BLOCKPROFIL NL - Dormant avec le nez + ouvrant de porte, ouverture vers l'intérieur



BLOKPROFIEL NL - Kader met aanslag / neusje deur vleugel, naar binnen opendaariend



BLOCKPROFIL NL - Rahmen mit nase Türflügel, nach Innen öffnend



BLOCKPROFIL NL - Telaio con nosa + anta della porta, l'apertura verso interno



BLOCKPROFIL NL

140x57

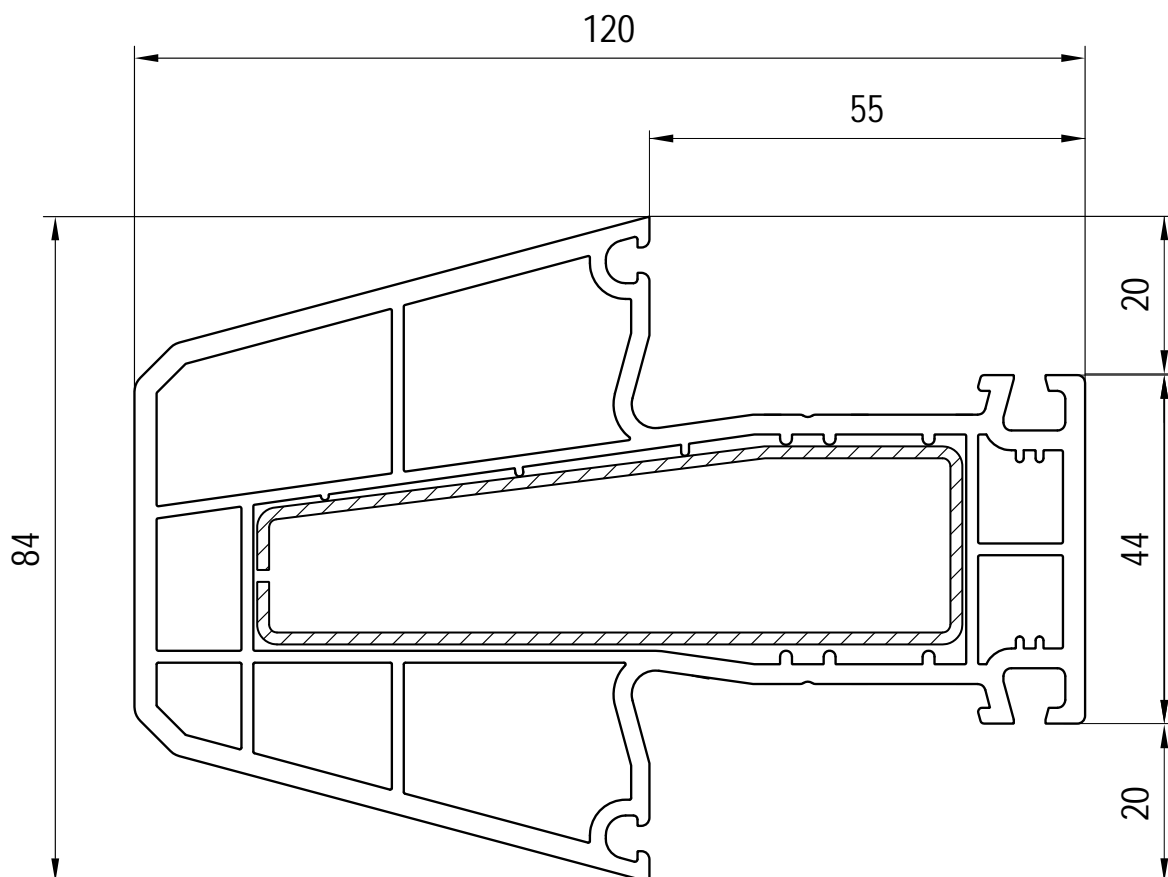

BLOCKPROFIL NL - Słupek stały dla ramy NL



BLOCKPROFIL NL - Meneau fixe pour dormant NL



BLOKPROFIEL NL - Vaste stijl voor kader NL



BLOCKPROFIL NL - Fester Pfosten für Rahmen NL



BLOCKPROFIL NL - Montante fisso per telaio NL



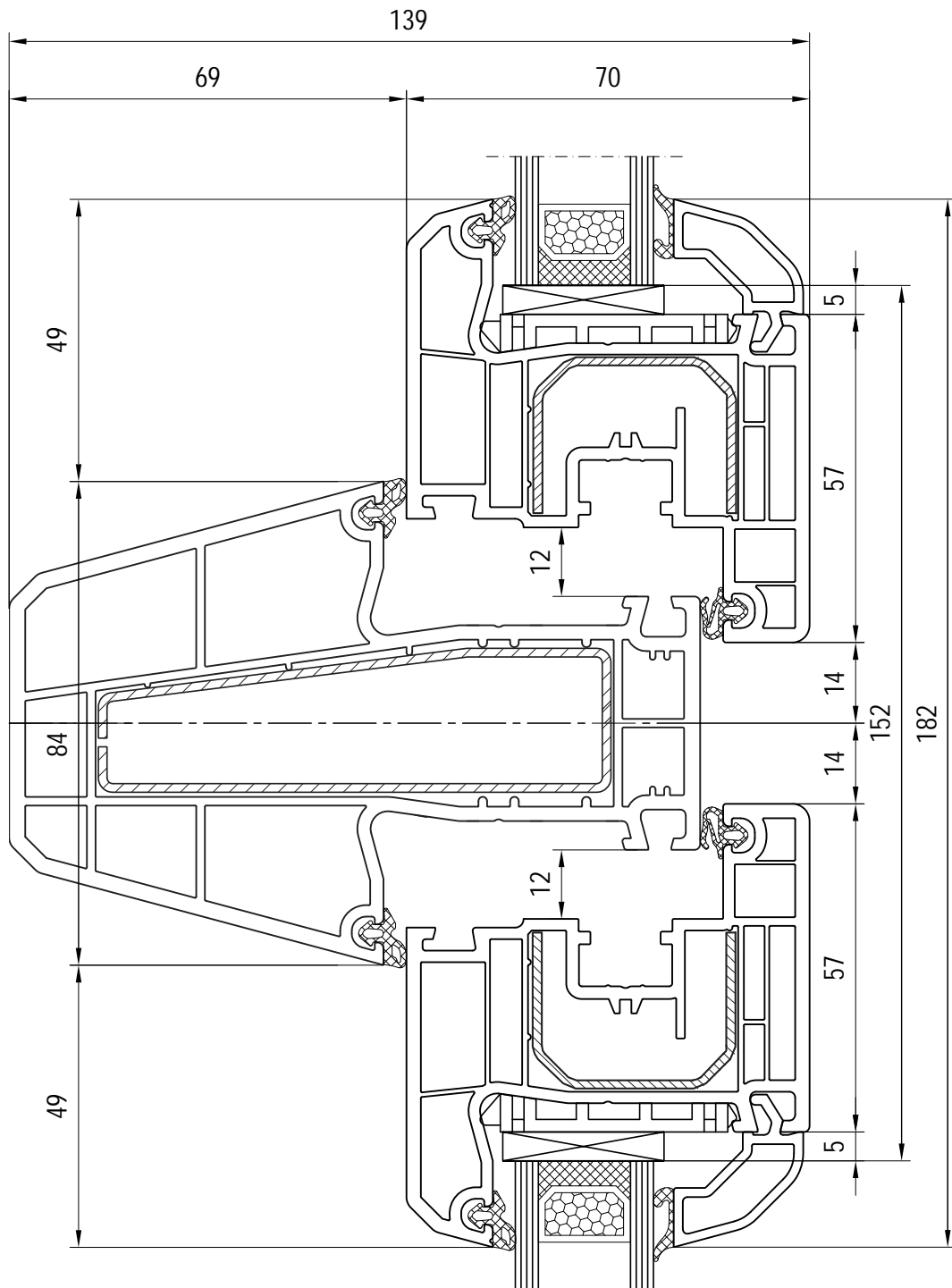

BLOCKPROFIL NL - Przekrój przez słupek stały z dwoma skrzydłami okiennymi Soft-line



BLOCKPROFIL NL - Coupe de deux ouvrants de fenêtre Soft-line avec meneau fixe



BLOKPROFIEL NL - Aansluiting van twee raam vleugels Soft-line met vaste stijl



BLOCKPROFIL NL - Zwei Fensterflügel Soft-line, verbunden mit Hilfe eines breiten Stulps



BLOCKPROFIL NL - Giunzione di due ante finestra Soft-line con montante fisso

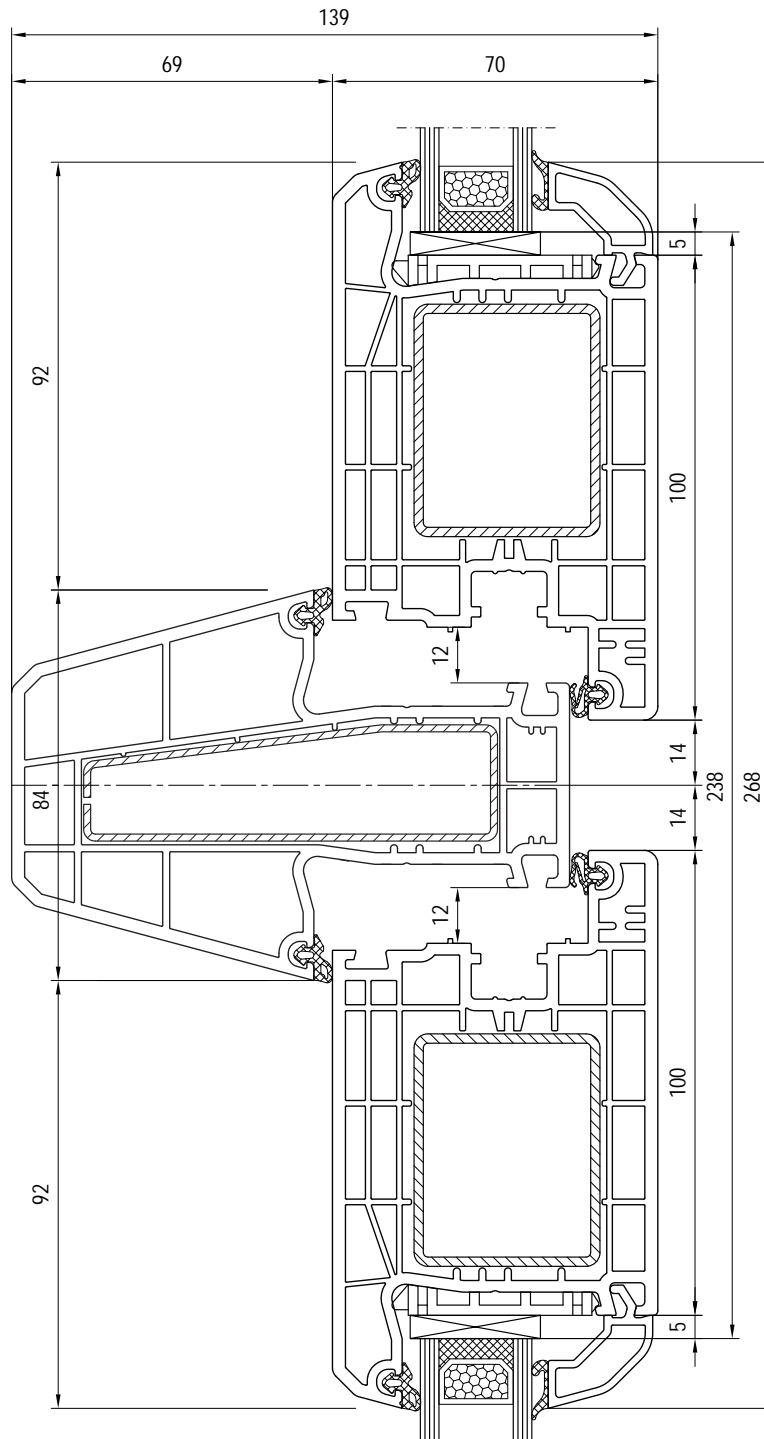

BLOCKPROFIL NL - Przekrój przez słupek stały z dwoma skrzydłami drzwiowymi, otwierane do wewnątrz



BLOCKPROFIL NL - Profil de porte avec memeau fixe, ouverture vers l'intérieur



BLOKPROFIEL NL - Deur profiel verbonden met vaste stijl, naar buiten opendraaiend



BLOCKPROFIL NL - Türprofil verbunden mit Hilfe eines festen Pfosten, nach Aussen öffnend



BLOCKPROFIL NL - Giunzione della porta con montante fisso, l'apertura verso interno



BLOCKPROFIL NL

140x53 - 140x58 - 140x31

**OKO
OKNA**

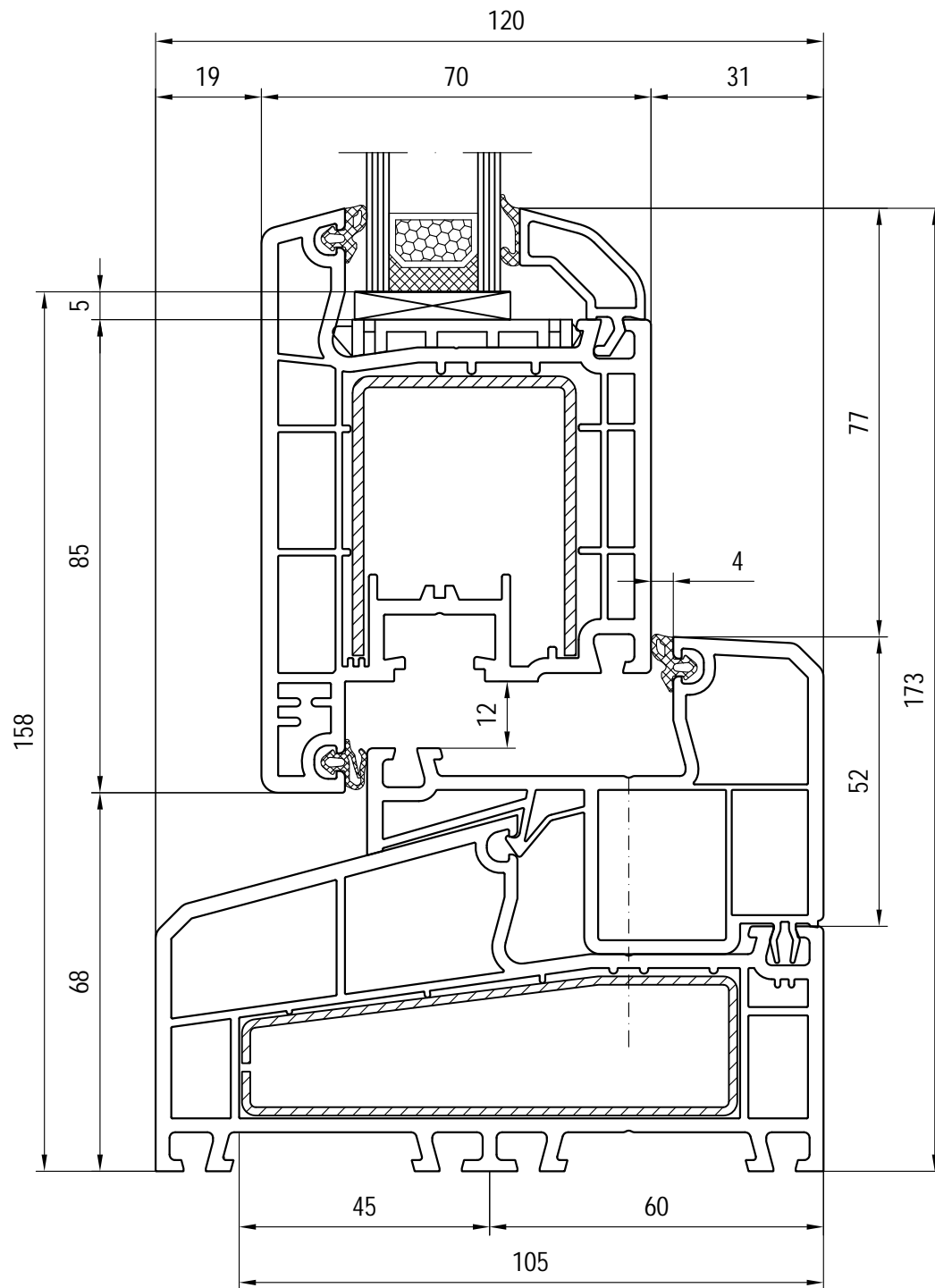

BLOCKPROFIL NL - Rama NL (bez noska) ze skrzydłem tarasowym, otwierane na zewnątrz

BLOCKPROFIL NL - Ouvrant de passage (sans le nez), ouverture vers l'extérieur

BLOKPROFIEL NL - Terras vleugel (zonder aanslag / neusje), naar buiten opendraaiend

BLOCKPROFIL NL - Terrassenflügel (ohne nase), nach Aussen öffnend

BLOCKPROFIL NL - Anta della portaveranda (senza naso), l'apertura verso esterno



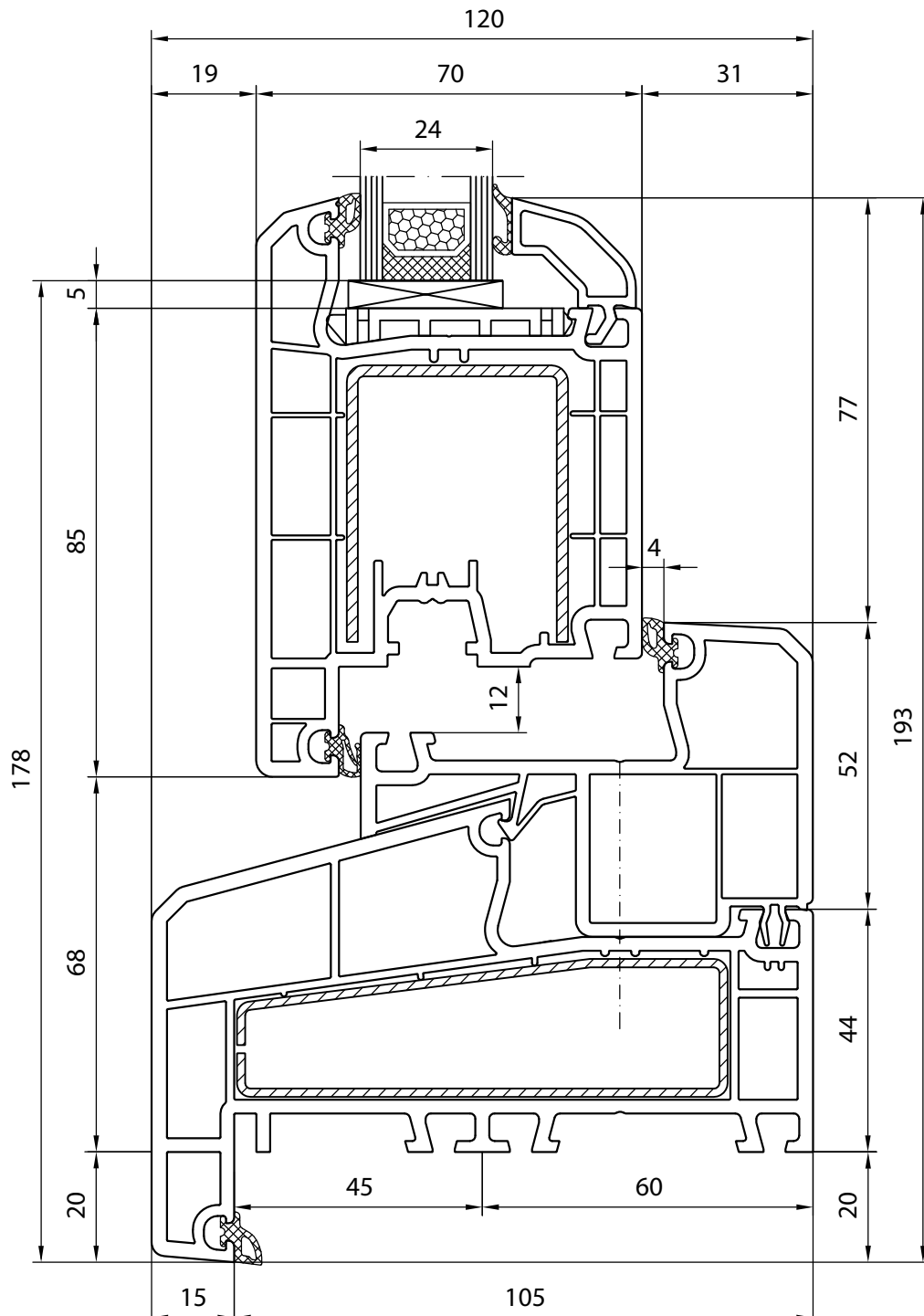

BLOCKPROFIL NL - Rama NL (z noskiem) ze skrzydłem tarasowym, otwierane na zewnątrz



BLOCKPROFIL NL - Ouvrant de passage avec le nez, ouverture vers l'extérieur



BLOKPROFIEL NL - Terras vleugel met aanslag / neusje, naar buiten opendraaiend



BLOCKPROFIL NL - Terrassenflügel mit nase, nach Aussen öffnend



BLOCKPROFIL NL - Anta della portaveranda con nosa, l'apertura verso esterno



BLOCKPROFIL NL

140x53 - 140x58 - 140x35

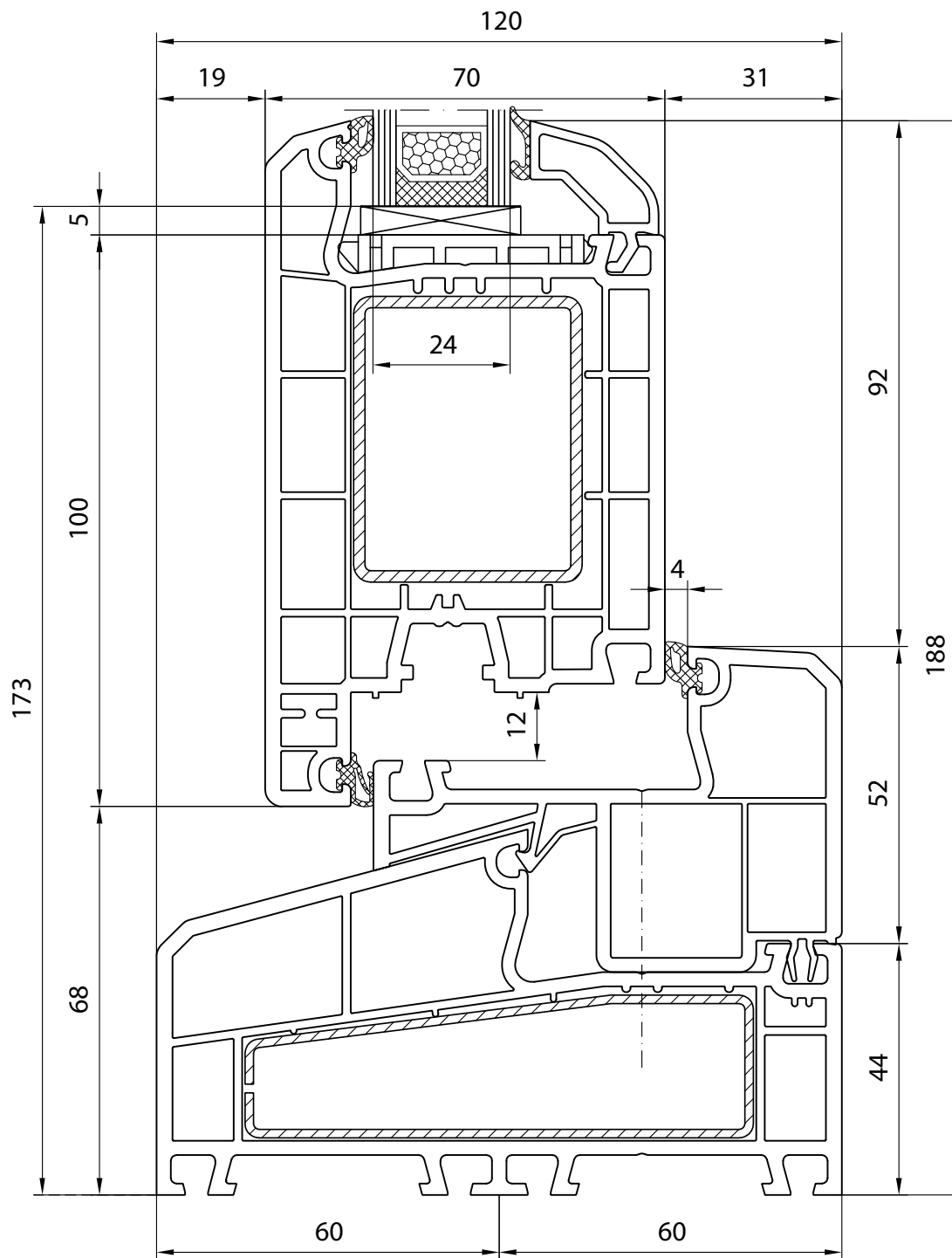

BLOCKPROFIL NL - Rama NL (bez noska) ze skrzydłem drzwiowym, otwierane na zewnątrz

BLOCKPROFIL NL - Ouvrant de porte (sans le nez), ouverture vers l'extérieur

BLOKPROFIEL NL - Deur vleugel (zonder aanslag / neusje), naar buiten opendraaiend

BLOCKPROFIL NL - Türflügel (ohne nase), nach Aussen öffnend

BLOCKPROFIL NL - Anta della porta (senza naso), l'apertura verso esterno



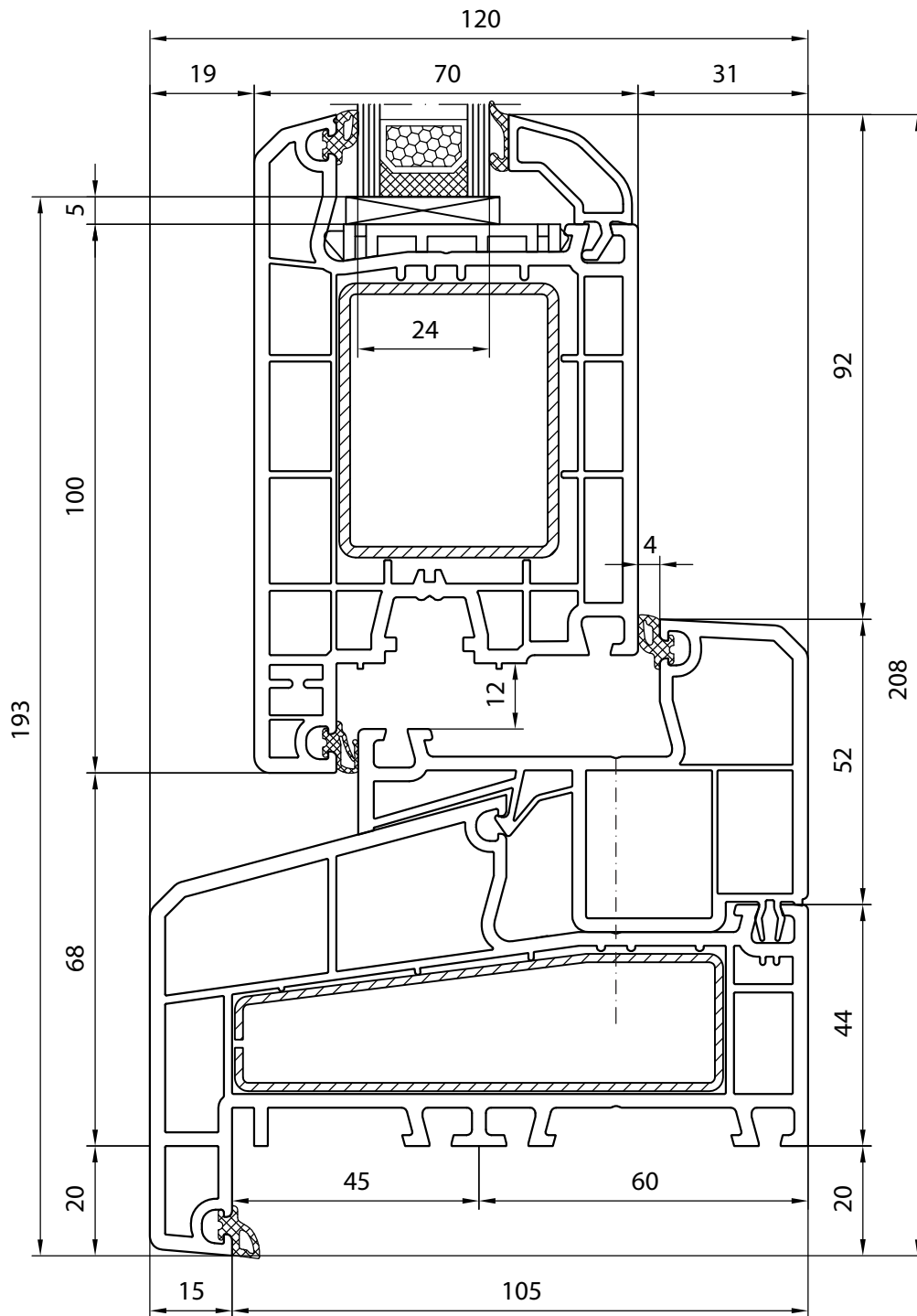

BLOCKPROFIL NL - Rama NL (z noskiem) ze skrzydłem drzewiowym, otwierane na zewnątrz



BLOCKPROFIL NL - Ouvrant de porte avec le nez, ouverture vers l'extérieur



BLOKPROFIEL NL - Deur vleugel met aanslag / neusje, naar buiten opendraaiend



BLOCKPROFIL NL - Türflügel mit nase, nach Aussen öffnend



BLOCKPROFIL NL - Anta della porta con nosa, l'apertura verso esterno



BLOCKPROFIL NL

140x41 - 140x20

**OKO
OKNA**

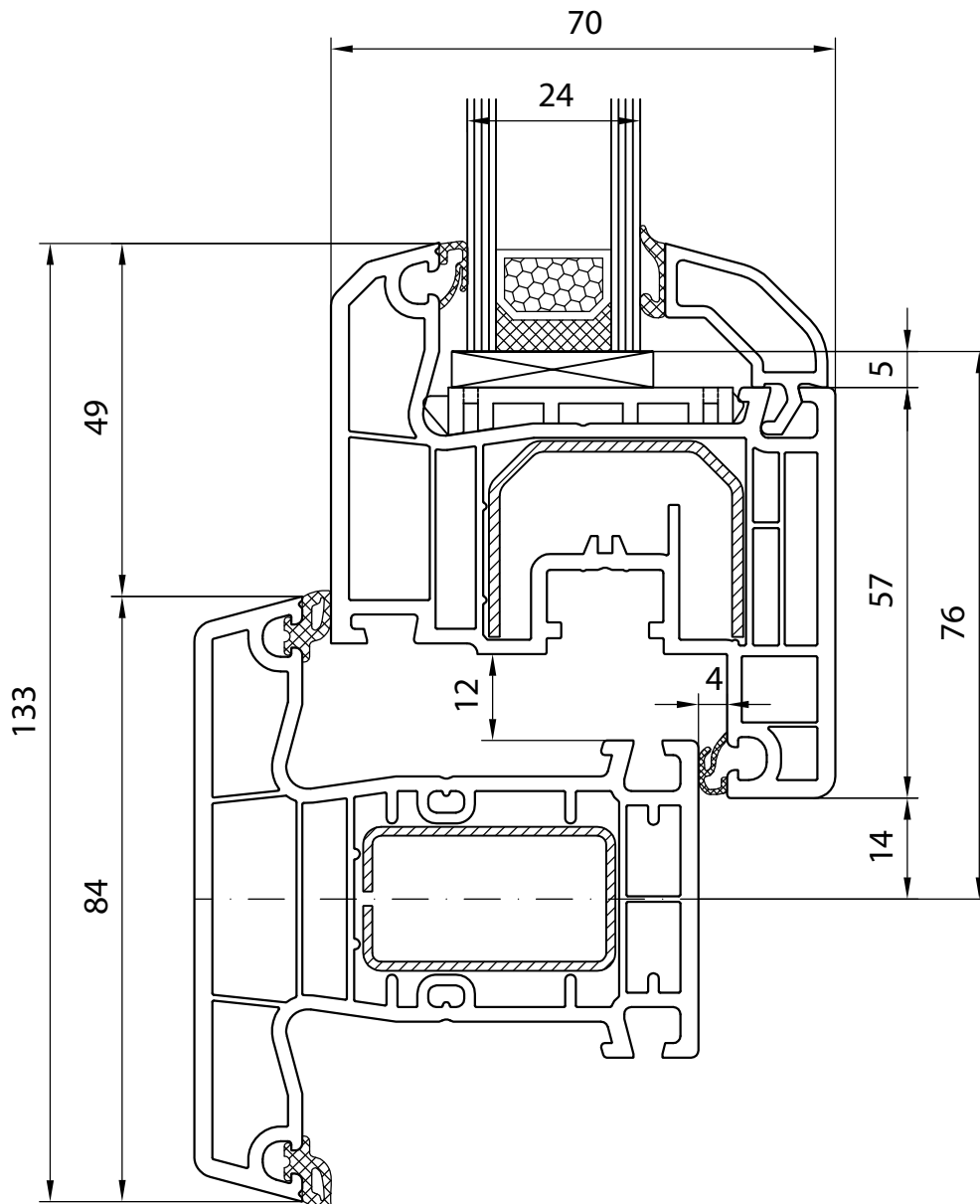

BLOCKPROFIL NL - Przekrój przez słupek stały (standard 84 mm) ze skrzydłem okiennym, Soft-line

BLOCKPROFIL NL - Coupe meneau fixe (standard de 84 mm) avec ouvrant, Soft-line

BLOKPROFIEL NL - Doorsnede, vaste stijl (std 84 mm) met vleuel, Soft-line

BLOCKPROFIL NL - Längsschnitt fenster Pfosten (std 84 mm) mit Flügel, Soft-line

BLOCKPROFIL NL - Sezione del montante fisso (standard 84 mm) con ante, Soft-line



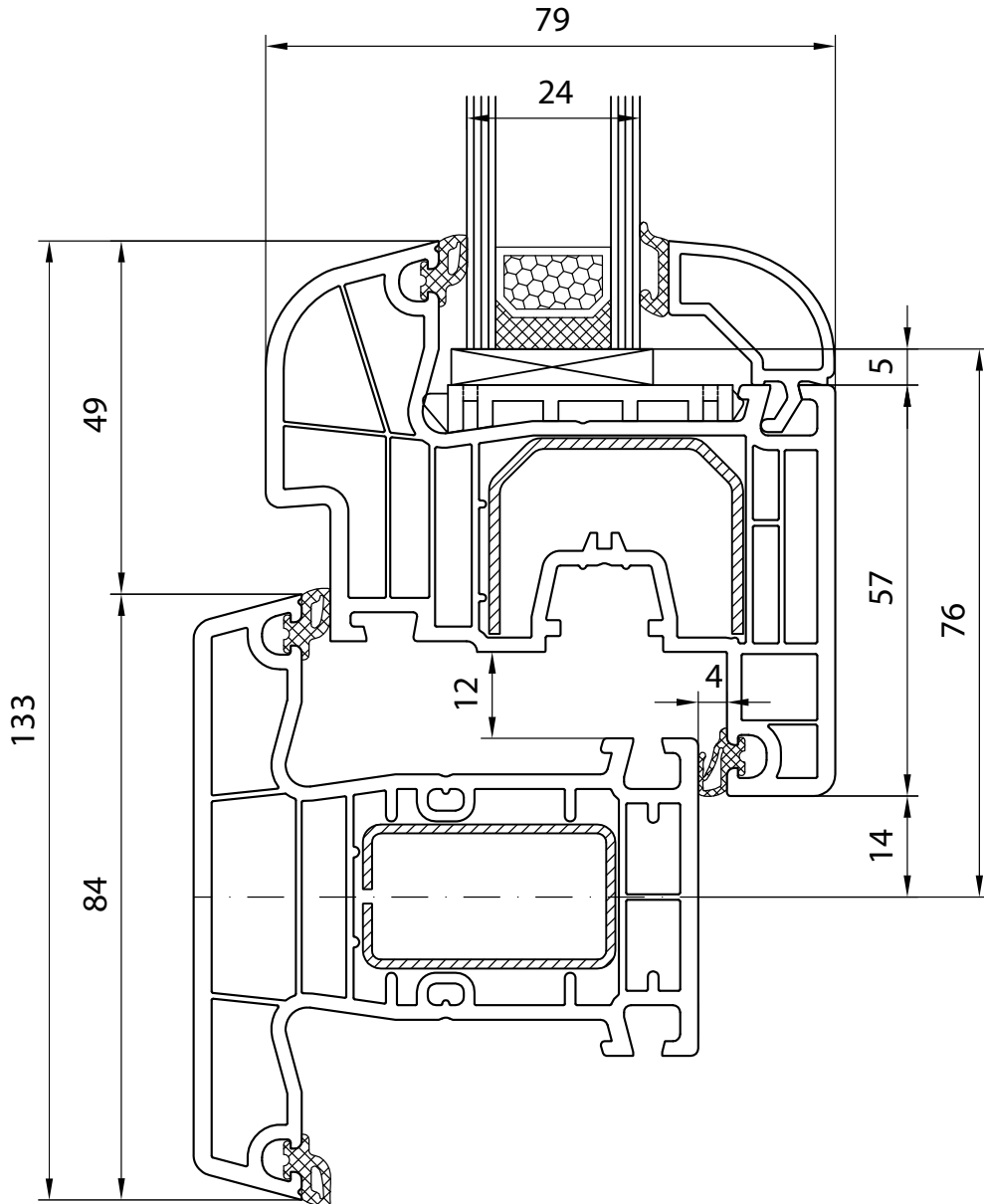
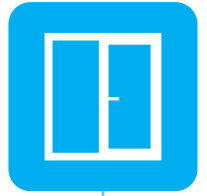

BLOCKPROFIL NL - Przekrój przez słupek stały (standard 84 mm) ze skrzydłem okiennym, Round-line



BLOCKPROFIL NL - Coupe meneau fixe (standard de 84 mm) avec ouvrant, Round-line



BLOKPROFIEL NL - Doorsnede, vaste stijl (std 84 mm) met vleuel, Round-line



BLOCKPROFIL NL - Längsschnitt Fenster Pfosten (std 84 mm) mit Flügel, Round-line



BLOCKPROFIL NL - Sezione del montante fisso (standard 84 mm) con ante, Round-line



BLOCKPROFIL NL

140x41 - 140x30

**OKO
OKNA**

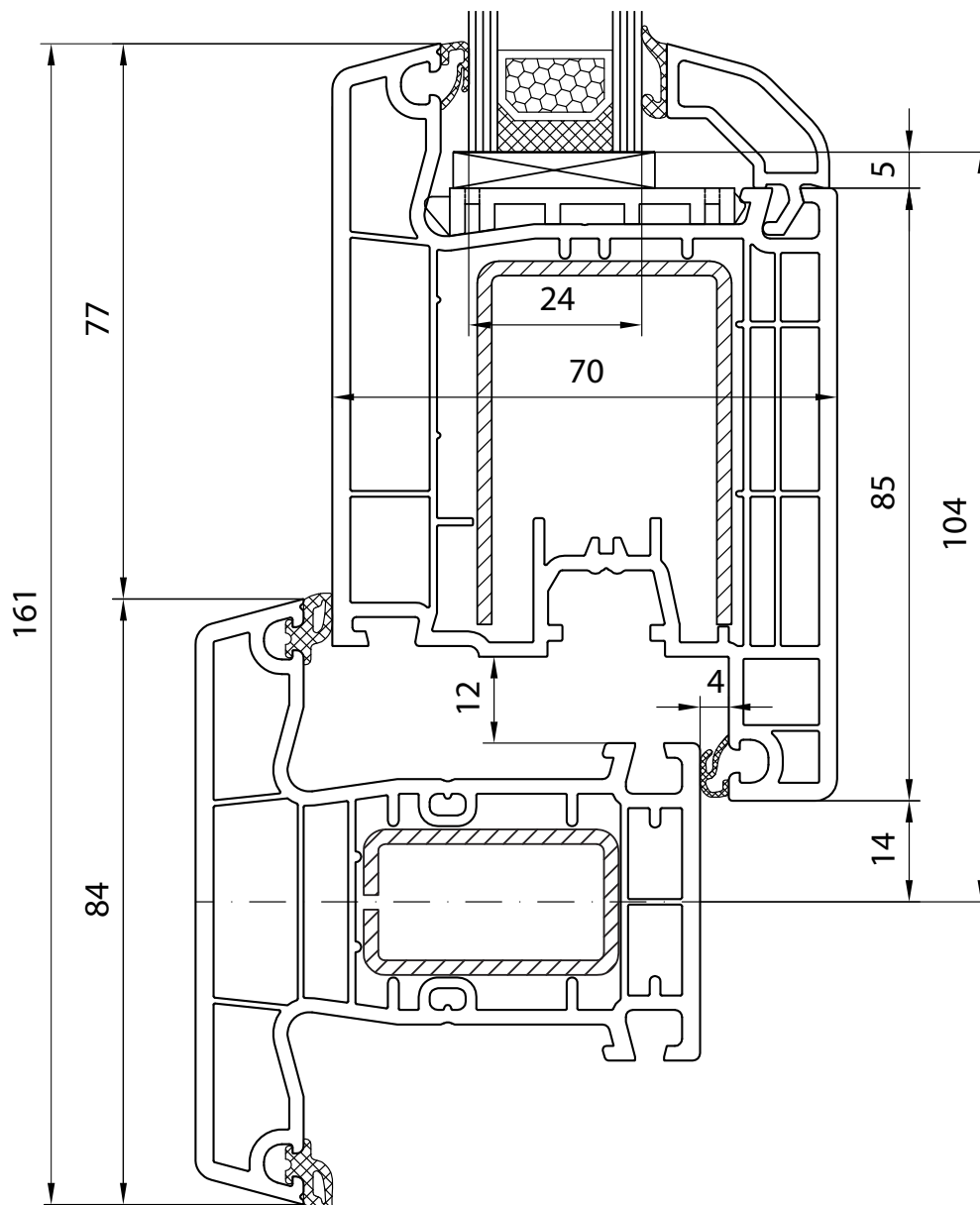

BLOCKPROFIL NL - Przekrój przez słupek stały 84 mm ze skrzydłem tarasowym, otwierane do wewnątrz

BLOCKPROFIL NL - Coupe profil de passage, ouvrant, ouverture vers l'intérieur avec meneau fixe de 84 mm

BLOKPROFIEL NL - Doorsnede terras profiel, vleugel naar binnen opendraaiend met vaste stijl 84 mm

BLOCKPROFIL NL - Längsschnitt Terrassentür mit Flügel, nach Innen öffnend mit festem Pfahl 84 mm

BLOCKPROFIL NL - Sezione della portaveranda ad ante, l'apertura verso interno con montante fisso 84 mm



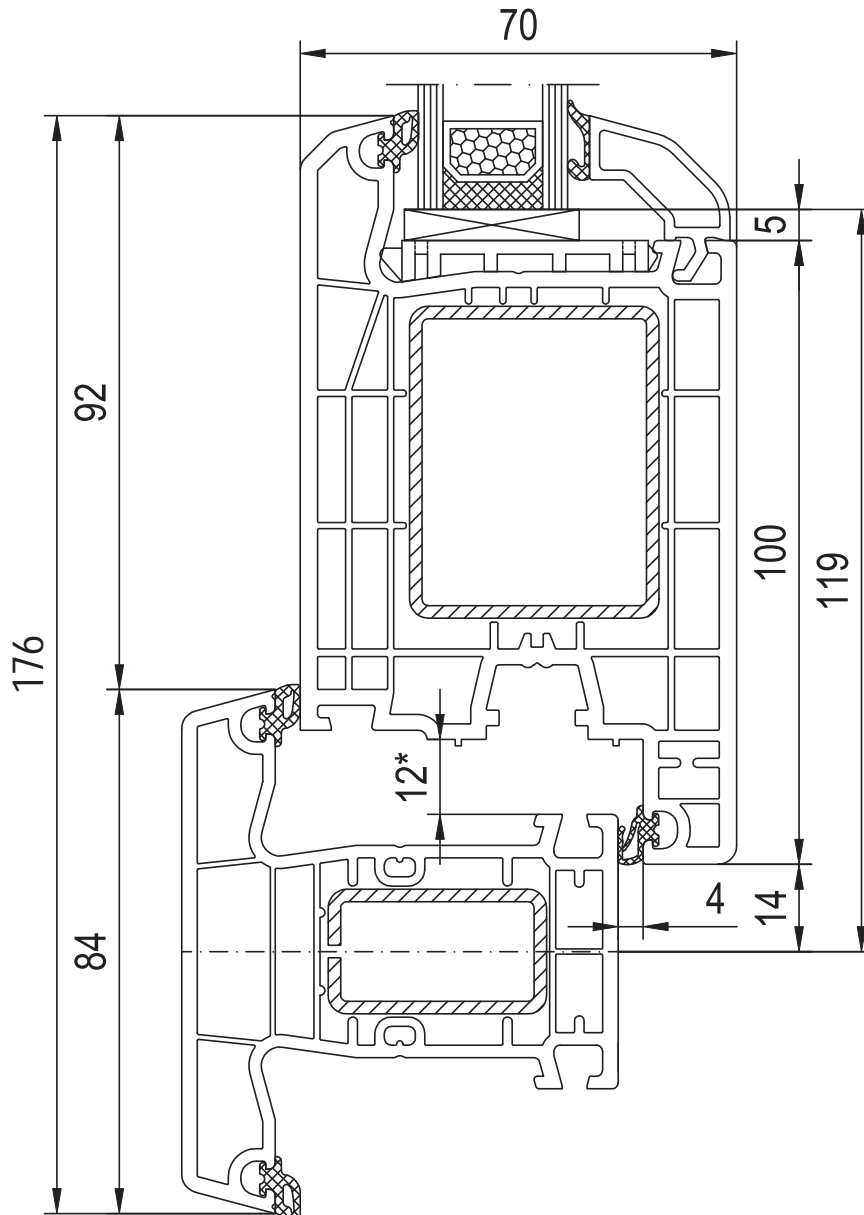

BLOCKPROFIL NL - Przekrój przez słupek stały 84 mm ze skrzydłem drzwiowym, otwierane do wewnątrz



BLOCKPROFIL NL - Ouvrant de porte avec meneau fixe de 84 mm, ouverture vers l'intérieur



BLOKPROFIEL NL - Deur vleugel met vaste stijl 84 mm, naar binnen opendraaiend



BLOCKPROFIL NL - Türflügel mit festem Pfahl 84 mm, nach Innen öffnend



BLOCKPROFIL NL - Anta portafinestra con montante fisso 84 mm, l'apertura verso interno



IDEAL 4000

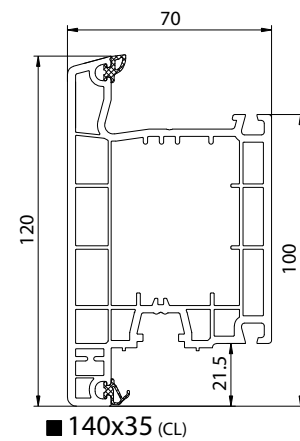
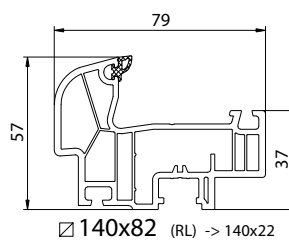
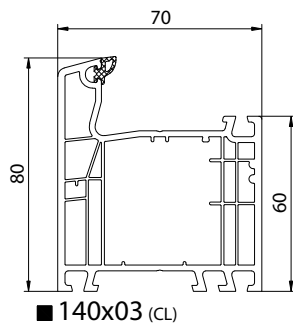
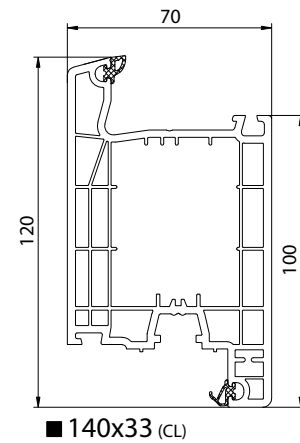
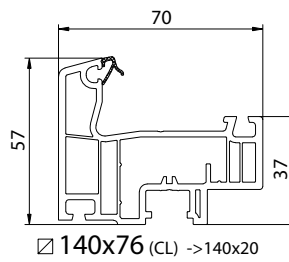
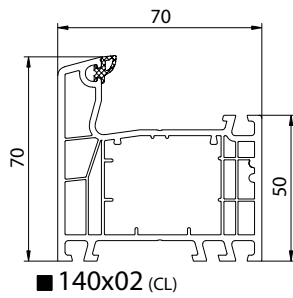
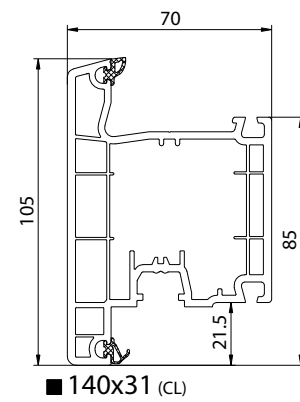
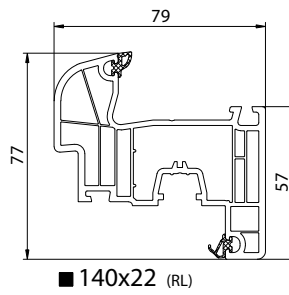
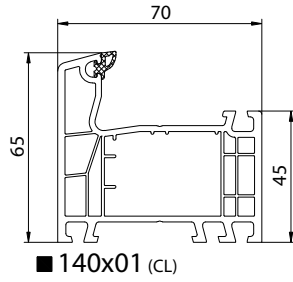
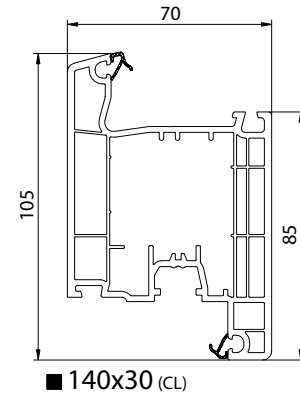
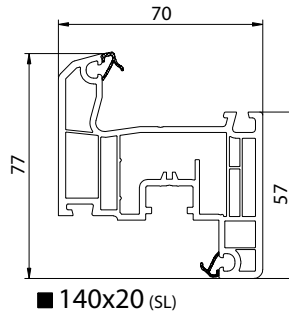
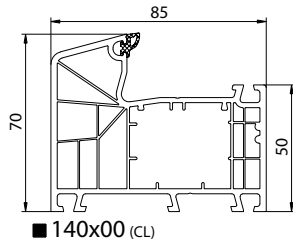

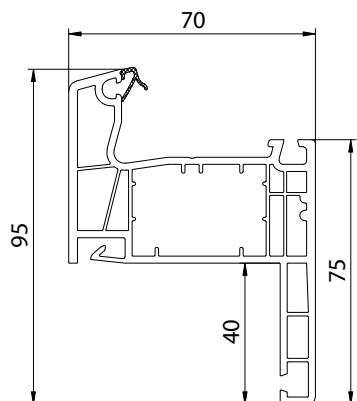
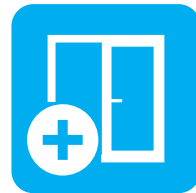

■ 140x15 (CL)

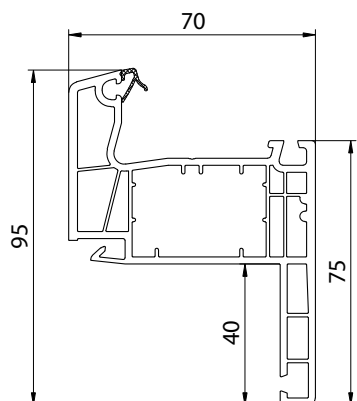

■ 140x17 (CL)

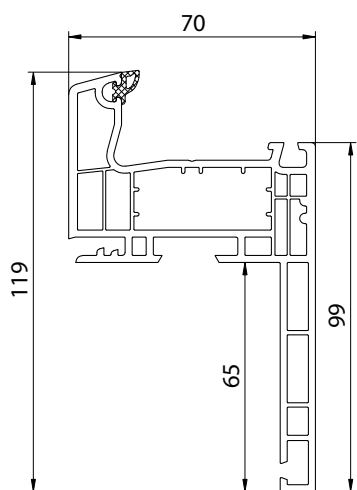

□ 140x10 (CL)

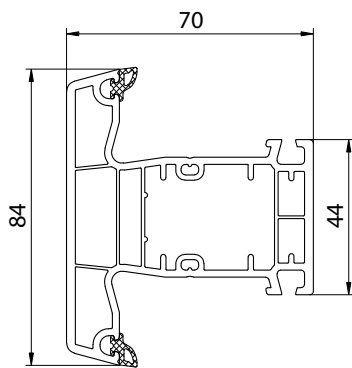

■ 140x41 (CL)

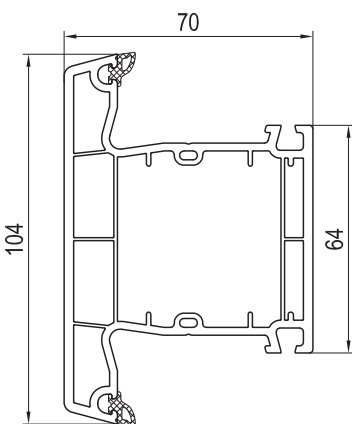

■ 140x45 (CL)

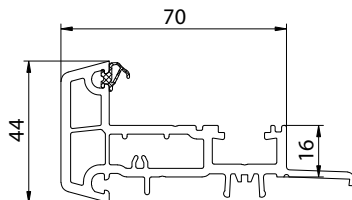

■ 140x65 (CL)

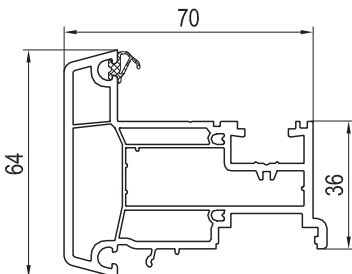

■ 140x66 (CL)

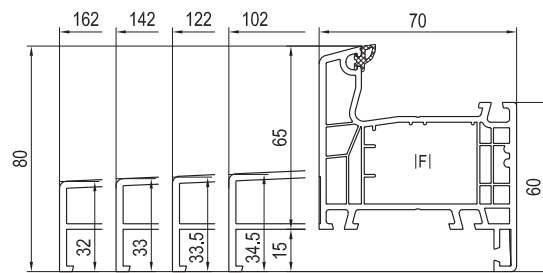

- 140x19 (CL)(MB)
- 140x18 (CL)(MB)
- 140x16 (CL)(MB)
- 140x14 (CL)(MB)
- 140x12 (CL)(MB)



IDEAL 5000

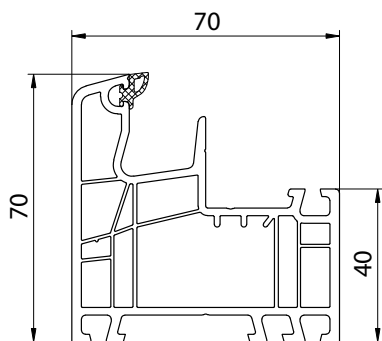

■ 150x02 (CL)

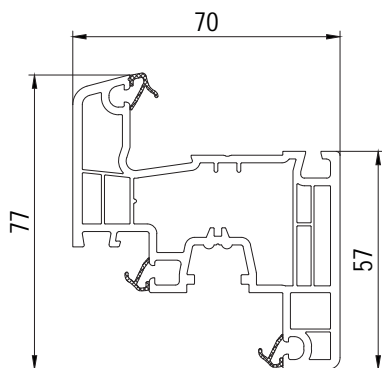

■ 150x20 (CL)

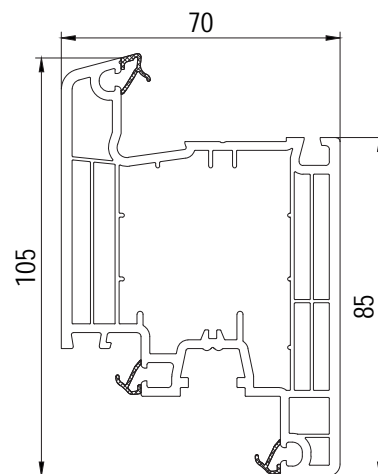

■ 150x30 (CL)

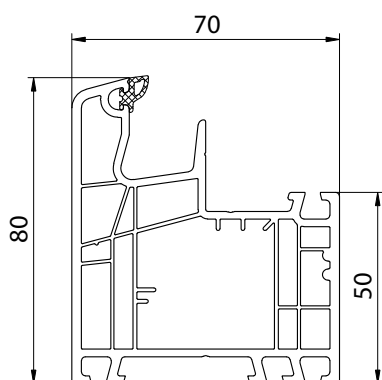

■ 150x03 (CL)

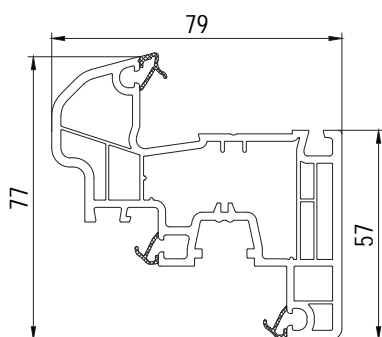

■ 150x26 (CL)

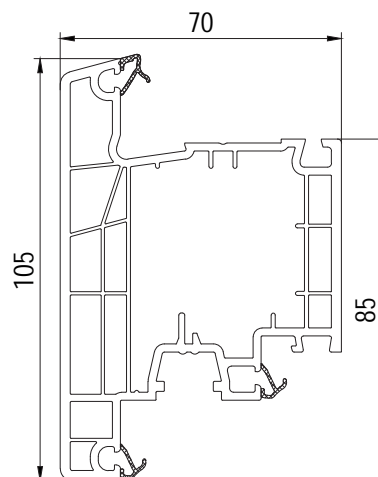

■ 150x31 (CL)

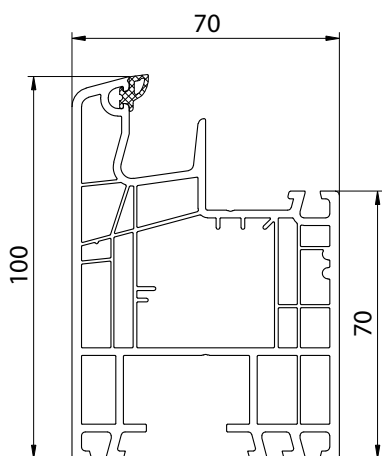

■ 150x04 (CL)



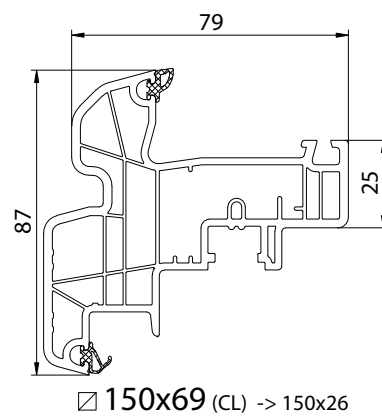
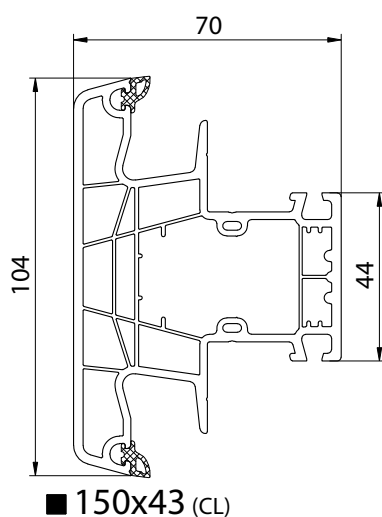
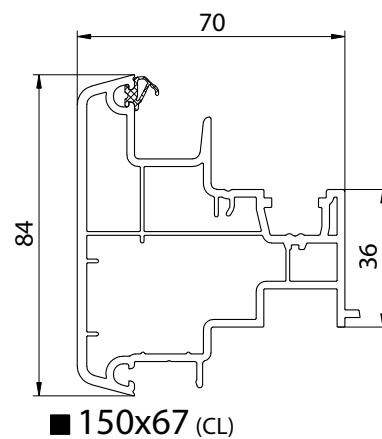
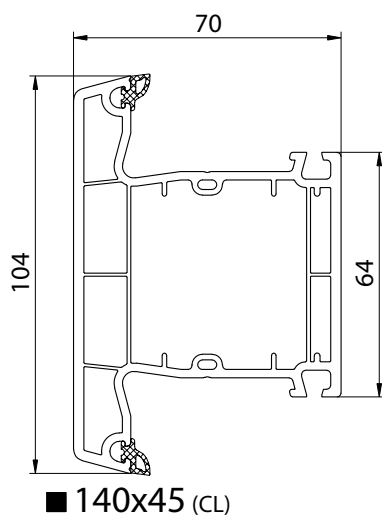
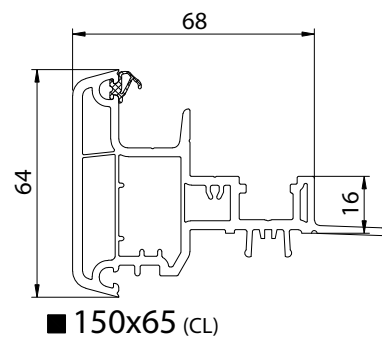
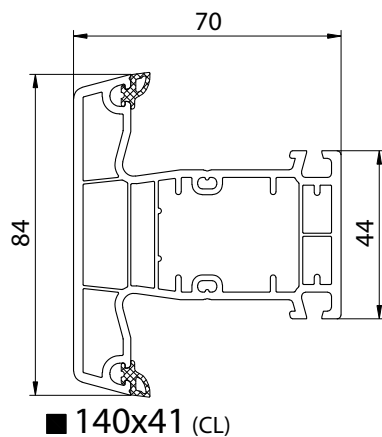
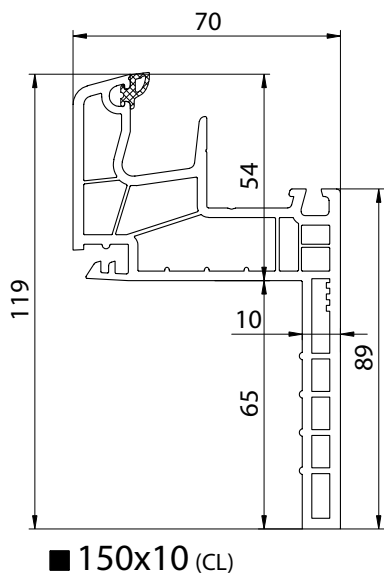
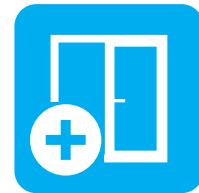



IDEAL 8000

**ЕКО
ОКНА**

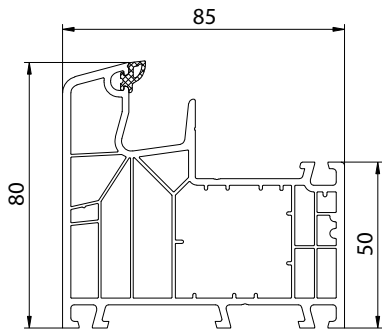

■ 180x05 (CL)

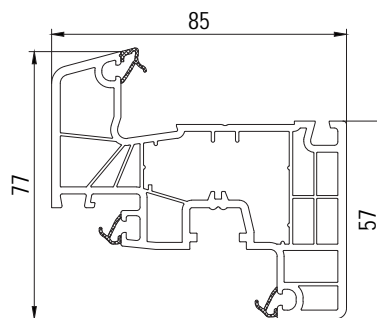

■ 180x20 (CL)

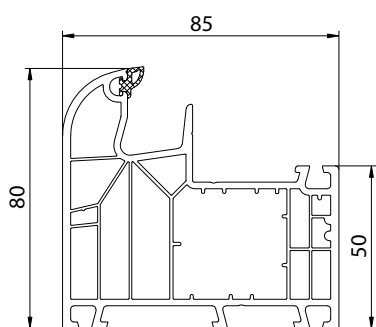

■ 180x03 (RL)

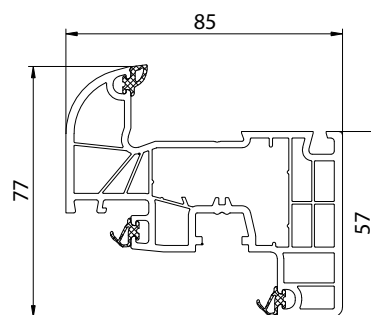

■ 180x22 (RL)

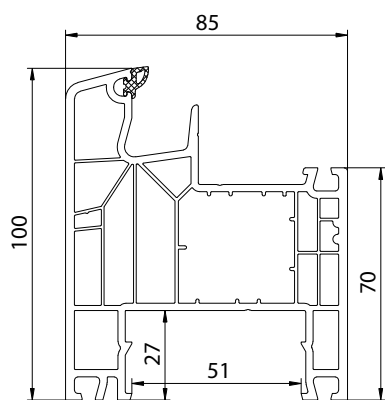

■ 180x04 (CL)

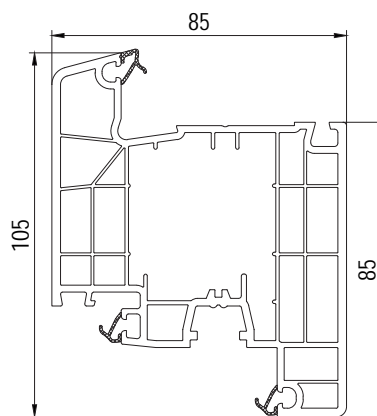

■ 180x30 (CL)

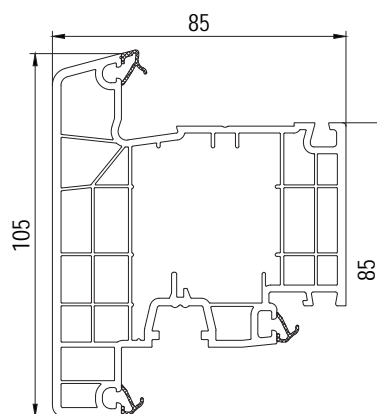

■ 180x31 (CL)



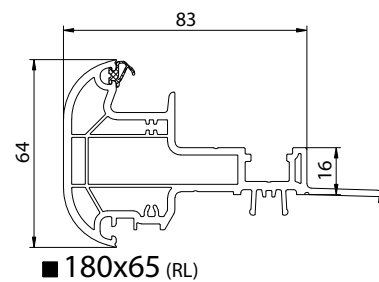
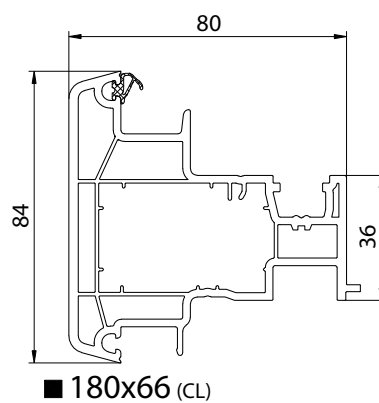
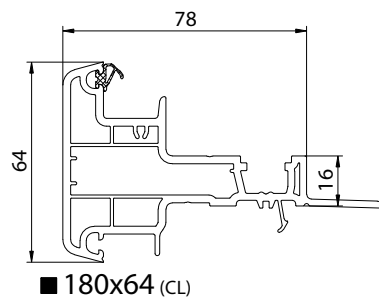
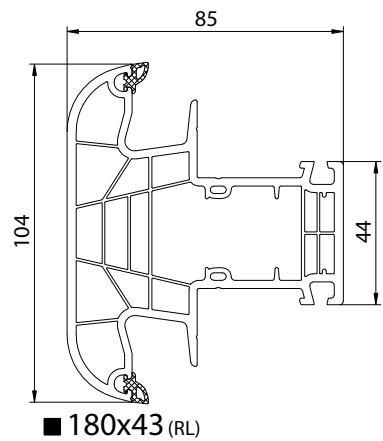
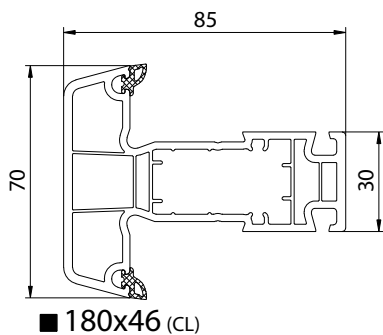
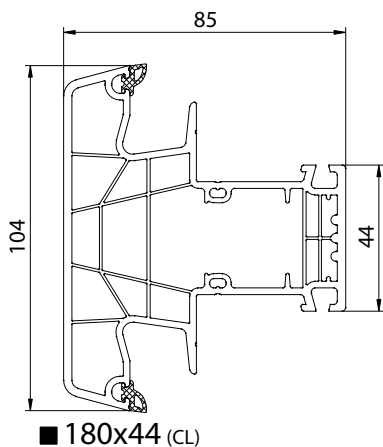
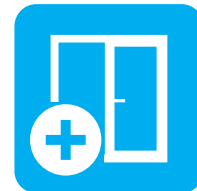

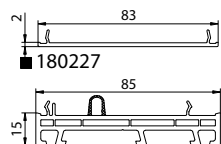
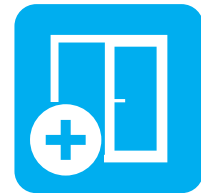

■ 180227

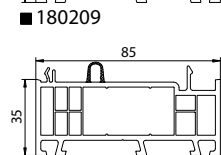

■ 180209

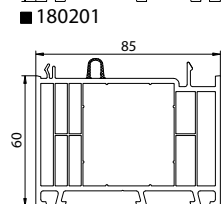

■ 180201

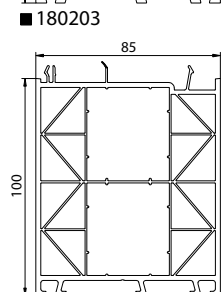

■ 180203

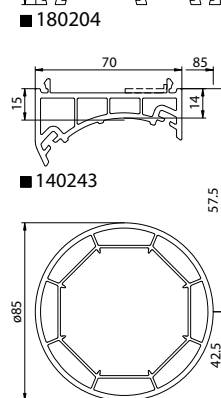

■ 140204

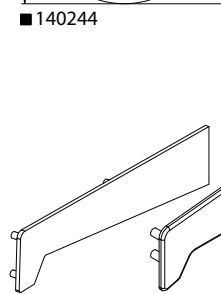

■ 140243



■ 140244

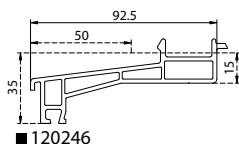

■ 120246

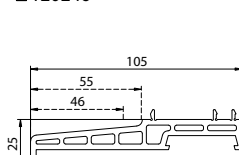

■ 120248

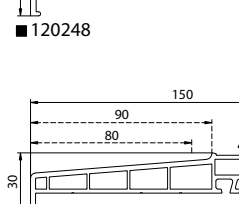

■ 120249

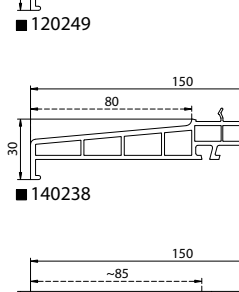

■ 140238

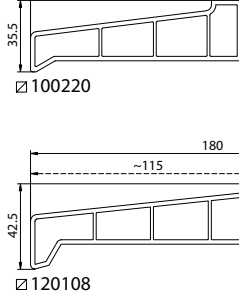

□ 100220

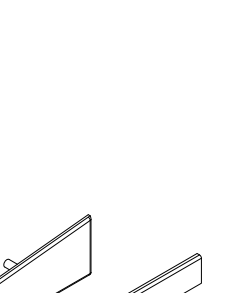

□ 120108

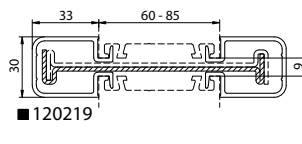

■ 120219

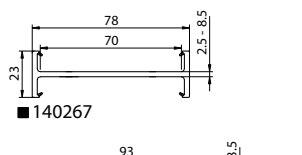

■ 140267

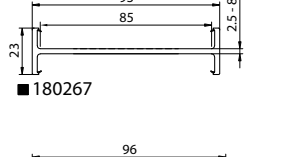

■ 180267

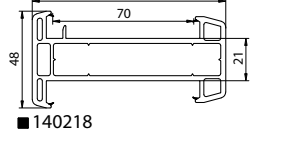

■ 140218

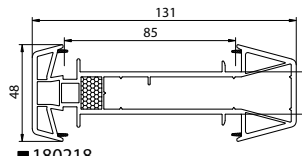

■ 180218

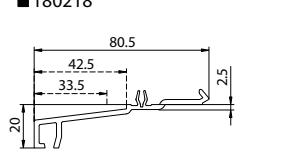

□ 140229

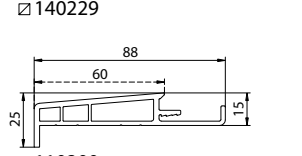

□ 110200

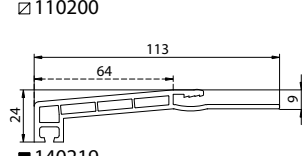

■ 140219

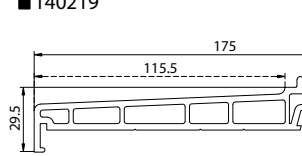

□ 120190

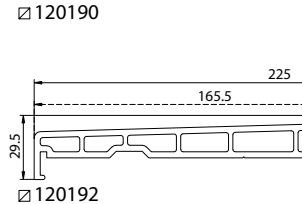

□ 120192

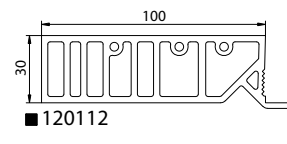

■ 120112

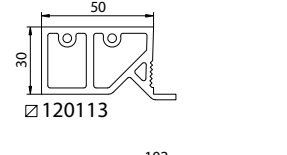

□ 120113

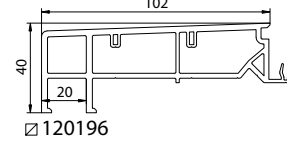

□ 120196

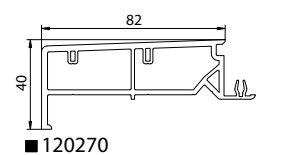

■ 120270

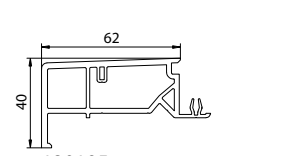

□ 120195

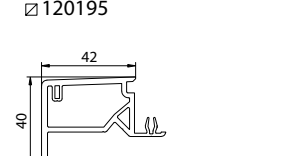

□ 120194

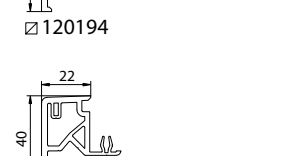

□ 120193

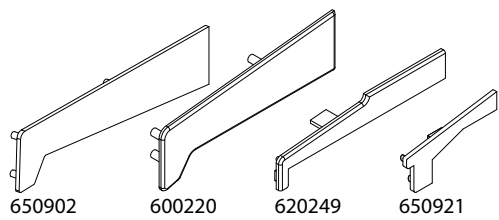

650902

600220

620249

650921



IDEAL

ЕКО
ОКНА

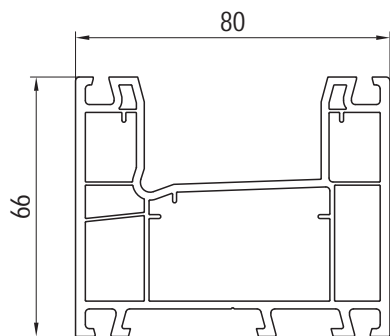

■ 100090 (CL)

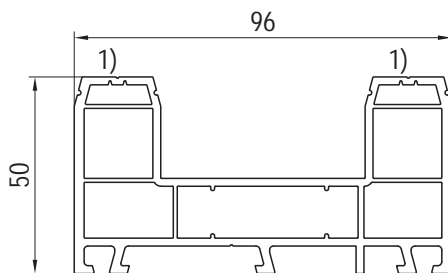

■ 100097 (CL)

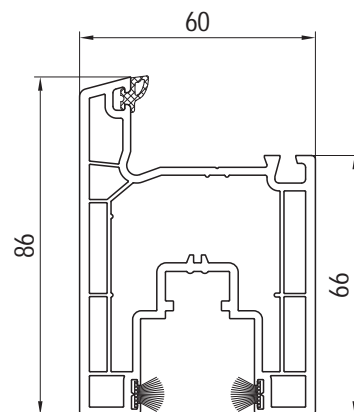

■ 100x92 (CL)

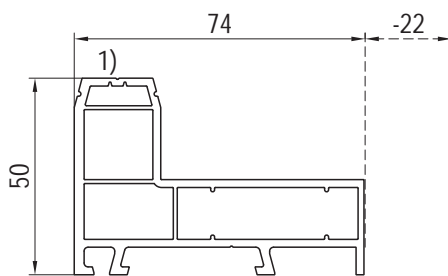

■ 100098 (CL)

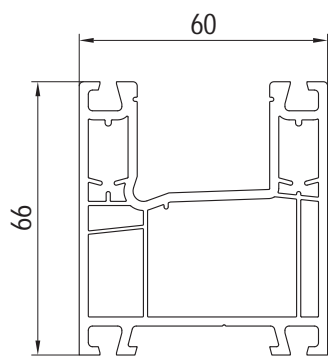

■ 100070 (CL)

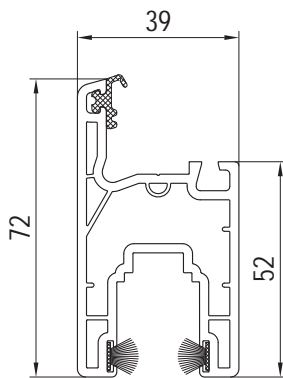

■ 100x72 (CL)





(AP 01)	(AP 02)	(AP 05)	(AP 06)
(AP 11)	(AP 15)	(AP 23)	(AP 27)
(AP 28)	(AP 29)	(AP 30)	(AP 32)
(AP 33)	(AP 34)	(AP 40)	(AP 41)
(AP 43)	(AP 44)	(AP 47)	(AP 50)
(AP 52)	(AP 60)	(AP 61)	(AP 62)
(AP 63)	(AP 65)	(AP 70)	(AP 71)
(AP 72)	(AP 75)	(AP 79)	(AP 88)
(AP 89)	(AP 94)	(AP 95)	(AP 101)
(AP 102)	(AP 103)	(AP 104)	(AP 105)



System Ideal - Paleta kolorów



Système Ideal - Palette de couleurs



Systeem Ideal - Kleurenpalet



System Ideal - Farbpalette



Sistema Ideal - Mazzetta colori

1/2017

